

# excavator mounted vibrator | EMV 550



## excavator mounted vibrator

owners manual  
operators instructions  
spare parts list  
safety precautions  
maintenance

EMV550 ver. 2021-01

DAWSON CONSTRUCTION PLANT LTD.  
CHESNEY WOLD,  
BLEAK HALL  
MILTON KEYNES  
MK6 1NE, ENGLAND  
TEL: +44 (0) 1908 240300  
FAX: +44 (0) 1908 240222  
EMAIL: JON@DCPUK.COM



[www.dcpuk.com](http://www.dcpuk.com)



# preface

This manual is used to familiarise you with safety, assembly, operation, adjustment, troubleshooting, and maintenance. Read and follow the recommendations in this manual to ensure safe and efficient operation. Keep this manual with the attachment at all times for future reference.

We want you to be completely satisfied with your new product, feel free to contact your local authorized service dealer for help with service, replacement parts, or any other information you may require. If you need assistance in locating a dealer, visit our web site at [www.dcpuk.com](http://www.dcpuk.com) or call customer service at +44 (0) 1908 240300.

Whenever you contact your authorised service dealer, always have the model number and serial number of your product available. These numbers will help provide exact information about your specific product. You will find the model and serial numbers on an ID plate located on the product.

The descriptions and specifications in this manual are subject to change without notice. Dawson reserves the right to improve products. Some product improvements may have taken place after this manual was printed.

# table of contents

Preface / Table of Contents	3
EU Declaration of Conformity	5
Basic Technical Specifications	6
Basic Safety Points	7-8
SAFETY FIRST - Quick Reference Guide	9-10
How does the EMV work?	11-12
Mounting Instructions	13-14
Operating Instructions	15-17
Operating Instructions - Driving Piles (Quick Reference Illustrations)	18-19
Operating Instructions - Extracting Piles (Quick Reference Illustrations)	20-21
Recommended Excavator Positions (Quick Reference Illustrations)	22
Maintenance	23-26
Troubleshooting	27-30
EMV550 hose kit	31-33
Parts lists for the EMV550 - Assembly Drawing	34
Appendix A- Auxiliary equipment (The EMV inspection procedure is also included with this document.)	-







**DAWSON**  
**CONSTRUCTION PLANT LTD**  
 Dawson Construction Plant Ltd  
 Chesney Wold,  
 Bleak Hall,  
 Milton Keynes  
 MK6 1NE, ENGLAND  
 Tel: (+44) 1908 240300  
 Fax: (+44) 1908 240222  
 E-Mail: dawson@dcpuk.com  
 Website: www.dcpuk.com



# Certificate

## Declaration of Conformity

We declare that the machinery/equipment detailed below is in compliance with the applicable regulations and harmonised standards as listed. This declaration ceases to be valid if alterations are made to the machinery/equipment without agreement with Dawson Construction Plant Ltd.

Category	Piling Equipment
Type	EMV 550
Serial Number	55-052
Year of Manufacture	2021
Power kW	120
Suitable Excavator Range	30-55 tonnes

Relevant Regulations:

2006/42/EC	Machinery Directive
2000/14/EC	Noise emission in the environment -

Measured sound power level on machines representative of this type  
 Applied conformity assessment procedure according to Annex VIII 113 dB (A)  
 Technical documentation archive location: MK6 1NE

Applied harmonised standards, in particular:

EN 12100:2010	Safety of machinery. Basic terminology and methodology
EN 16228-1:2014	Drilling & foundation equipment. Common requirements
EN 16228-4:2014	Drilling & foundation equipment. Foundation Equipment
EN 16228-7:2014	Drilling & foundation equipment. Interchangeable auxiliary equipment

Signed by on behalf of DCP

Name / Position

DAVID BROWN - MANAGING DIRECTOR

Date

13 / 08 / 2021

# basic technical specifications

SPECIFICATIONS	EMV550	
	METRIC	US
UNITS	METRIC	US
STATIC MOMENT	8.23 kgm	714 in lbs
FREQUENCY	2,500 rpm	
CENTRIFUGAL FORCE	564 KN	125,592 lbs.F
AMPLITUDE	13.7 mm	0.54 in
MIN HYDRAULIC FLOW RATE	256 L/min	68 gpm
MAX HYDRAULIC FLOW RATE	400 L/min	107gpm
MAX. HYDRAULIC PRESSURE	350 bar	5,076 psi
MIN. HYDRAULIC POWER	120 kW	160 hp
DYNAMIC MASS	1,150 kg	2,576 lbs
TOTAL MASS	1,500 kg	3,360 lbs
MAX. PILE MASS	1,400 kg	3,136 lbs
MAX. PUSH/PULL FORCE	22,500 kg	49,500 lbs
CLAMP FORCE	66 tonne	
TYPICAL EXCAVATOR WEIGHT	30 to 55 tonne	33 to 60 ton

\* REQUIRED FLOW = MAX. FREQUENCY  
MACHINE HAS INTEGRAL FLOW REGULATOR UPTO 120 L/min.

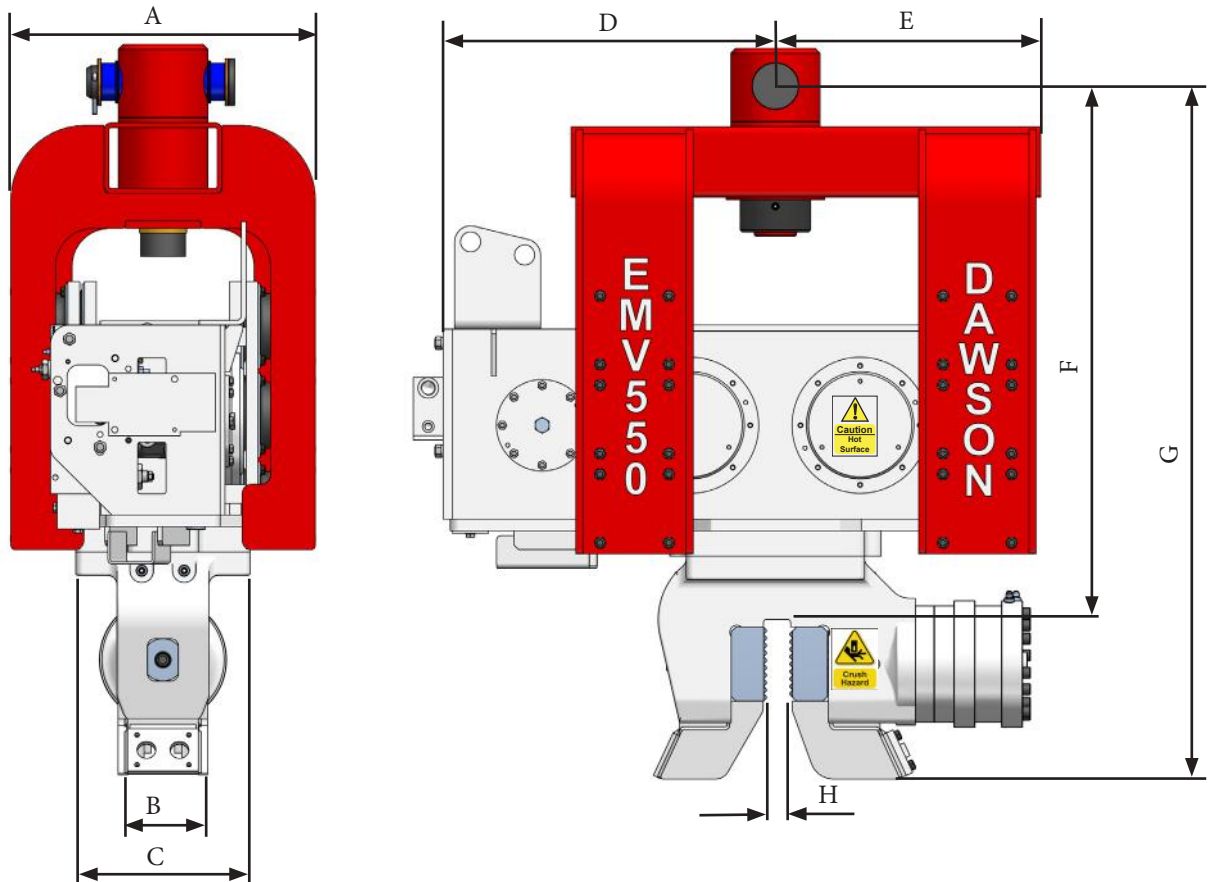

DIMENSIONS	A	B	C	D	E	F	G	H
mm	646	190	370	708	555	1137	1477	50
in	25.4	7.48	14.5	27.9	21.85	44.8	58.2	1.97

# basic safety points

- The vibrator should only be operated by suitably qualified personnel.
- The vibrator/clamps not to be used for lifting operations.
- It is prohibited to leave an element suspended in the clamps of a vibrator, which is free hanging and out of operation.
- Don't leave the vibrator clamped on a pile without being attached to the excavator.
- Extraction pulling force not to be exceeded.
- Pile to be secured to the lifting chain of equal lifting or greater capacity to the load held in the clamp.
- It is prohibited to use vibrator as an impact hammer, by hammering with open clamp.
- There should be visual contact between operator and slinger (banksman) at all times.
- Monitor the piling operation constantly – stop the process immediately if any danger occurs.
- Do not operate the vibrator if any person is within the **High Risk Area**– see high risk definition..
- Consider machine stability at all times.
- The operator should inspect the equipment for defects every day and before being taken in to service. Any defects that affect operational safety should be corrected before the equipment is taken into service.
- Pay attention to the Safe Working Load of all lifting accessories at all times. (See auxiliary equipment).
- The working area should be properly illuminated.
- Work safely at all times and within the requirements of all local legislation.
- The vibrator can become very hot during operation – do not touch it unless wearing appropriate protective clothing.



## WHO IS RESPONSIBLE?

Those who are in charge of, or responsible for, the use and maintenance must ensure that the vibrator and all its auxiliary equipment are in good condition.

Piling should only be carried out under the supervision of an appropriately qualified and experienced person who can assess that the work is carried out safely.

The excavator operator must ensure that his communication signals are understood, by those on the ground, and followed. During piling operations he must watch out for any potential hazards.



## WORKING CONDITIONS / ADVERSE WEATHER CONDITIONS

Vibrators should only be operated and driven on firm ground with clear visibility of the working area and the process monitored constantly. Operators must have a clear understanding of the site assessment and method statement. This assessment will cover risks and site actions that have been implemented for the event of adverse weather conditions.

The vibrator stand must stay upright on level ground (at all times) to avoid personnel injury.



## WORKING NEAR UNDERGROUND / OVERHEAD OBSTACLES

Before the start of any piling work it is up to the contractor to identify if there are any underground cables, utilities and overhead obstacles within the working area which could be dangerous to personnel, including but not limited to live electrical cables. This should be fully covered in the site specific method statement. All personnel on site should have a full understanding of the risks. In the case of unforeseeable contact or damage of an underground / overhead obstacle, then work must stop immediately and the person in charge informed.



## THE HIGH RISK AREA

This is an area defined as that being within an approximate radius of the vibrator which is calculated by the following formula: Pile length (m) +  $\frac{1}{2}$ (Pile Length)

This area can be either this or within the slewing radius of the excavator, whichever is greater. The **High Risk Area** is active while the vibrator is working or the excavator is in operation. (Please refer to operator's instruction for full details)

# continued - basic safety points

Personnel are at risk when within this area from:

- Falling piles – should the pile be handled incorrectly
- Liquids under high pressure and associated components
- Mechanical failures of equipment components
- Noise – wear ear protection equipment when inside this area
- Unexpected movement of the excavator (slewing, overturning)



## TRANSPORTING THE VIBRATOR

When transporting the vibrator, ensure it is placed correctly in the stand. Once in place on the stand the jaws must be closed. Release the hydraulic hoses from the excavator (the hard jaws will remain closed) and cap the hose ends to prevent contamination. Disconnect the vibrator from the excavator.



## TRANSPORTING PILES ON SITE

Transporting a pile using the vibrator should only be done over a small distance, with the clamp fully engaged on the pile top and with the lifting chain fitted. The load should be carried as close to the ground as possible to minimise falling risk. Should the grip on the pile be reduced during this procedure, the excavator must stop, and a better grip effected. Should a pile slip then the lifting chain could snap and cause an accident. When transporting a pile extreme care must be taken to ensure that no one is in the **High Risk Area** and that the pile is handled in such a way as to ensure no danger to site personnel at any time. In order to avoid extensive transporting, have the piles laid out as close to the point of installation as possible. Do not use the excavator with the EMV550 installed to handle bundles of piles around the job site. The maximum pile weight allowed to be transported by each EMV model is shown in the table below:

	MODEL				
	EMV70	EMV220	EMV300	EMV450	EMV550
MAX PILE MASS	800kg	800kg	800kg	1,000kg	1,400kg
LIFTING CHAIN SWL (t= 1000kg)	3.2t	3.2t	3.2t	1.6t STD CHAIN 3.2t ADAPTOR	1.6t STD CHAIN 3.2t ADAPTOR

# QUICK REFERENCE GUIDE

IMPORTANT:- READ FULL OPERATING INSTRUCTIONS @ WWW.DCPUK.COM

# SAFETY FIRST

## Basic Safety Points

The vibrator should only be operated by suitably competent personnel.

There should be visual contact between operator and banksman at all times.

Monitor the piling operation constantly - interrupt the process immediately if any danger occurs.

Do not operate the vibrator if any unauthorised personnel are within the HIGH RISK AREA. = ( Pile length +  $\frac{1}{2}$  Pile Length) or within the slewing radius of the excavator.

Consider machine stability at all times.

The operator should inspect the equipment for defects every day and before being taken into service.

Any defects that affect operational safety should be corrected before the equipment is taken into service

Pay attention to the Safe Working Load of all lifting accessories at all times.

The working area should be properly illuminated.

Work safely at all times and within the requirements of all local legislation.

The vibrator can become very hot during operation - do not touch it unless wearing appropriate protective clothing.

The maximum weight of pile that can be used with the;

EMV70, 220, 300 = 800kg

EMV450 = 1000kg

EMV550 = 1400kg

The most important hose on the machine is the drain line which must be fed either directly into the hydraulic tank in the excavator or connected to the breaker circuit return line. (Recommended  $\text{Ø}1/2$ " hose minimum).



### **WARNING!**

**IT IS IMPERATIVE THAT THE DRAIN LINE IS NOT RESTRICTED AS THIS WILL CAUSE THE BUILD UP OF PRESSURE WHICH WILL DAMAGE THE MOTOR.**

## Responsibility

Those who are in charge of, or responsible for the use and maintenance must ensure that the vibrator and all its auxiliary equipment are in good condition.

Piling should only be carried out under the supervision of an appropriately qualified and experienced person who can assess that the work is carried out safely.

The excavator operator must ensure that his communication signals are understood, by those on the ground, and followed. During piling operations he must watch out for any potential hazards.

The equipment is hired under C.P.A. conditions and as such any theft or damage caused by misuse or abuse will be charged accordingly.

IN THE EVENT OF MALFUNCTION, DAMAGE OR LEAKAGE OF OIL, DAWSON CONSTRUCTION PLANT MUST BE NOTIFIED IMMEDIATELY.

## Operating Procedures Summary - Read Full Operating Instructions at [www.dcpuk.com](http://www.dcpuk.com)

Allow the excavator engine to warm up, particularly in temperatures below 10°C.

Pay daily attention to the general condition of the hard jaws (vibrator clamp). Ensure they are replaced once signs of wear are apparent. Check for loosened connections daily.

Check both the vibrator and auxiliary equipment for damage. Pay particular attention to the lifting chain assembly. Any defects should be immediately notified to the person in charge. **DO NOT OPERATE A DAMAGED UNIT.** The Ø40mm hole in the pile for the lifting chain must be spaced 250mm from the top of the pile to avoid clash with the EMV jaws.

**Refusal** - Under normal conditions, refusal is defined when the time taken to drive a pile 250mm exceeds 5 minutes. The penetration distance of 250mm is absolute, i.e. No conversion is allowed, for instance, 20 minutes for 1m penetration.

**Rebound** - This occurs when a large proportion of the hammers energy is reflected back up through the pile as a result of hitting an impenetrable layer or obstruction. The reflected forces will be transferred back into the hammer and the suppressor head, and as a result, the head will start "jumping" relative to the vibratory case. In this situation driving should be stopped immediately.

If the pile reaches premature refusal then it will be necessary to loosen up the ground, possibly through drilling. **UNDER NO CIRCUMSTANCES SHOULD THE PILE BE FORCED FURTHER.** Alternatively a larger piling device should be used.

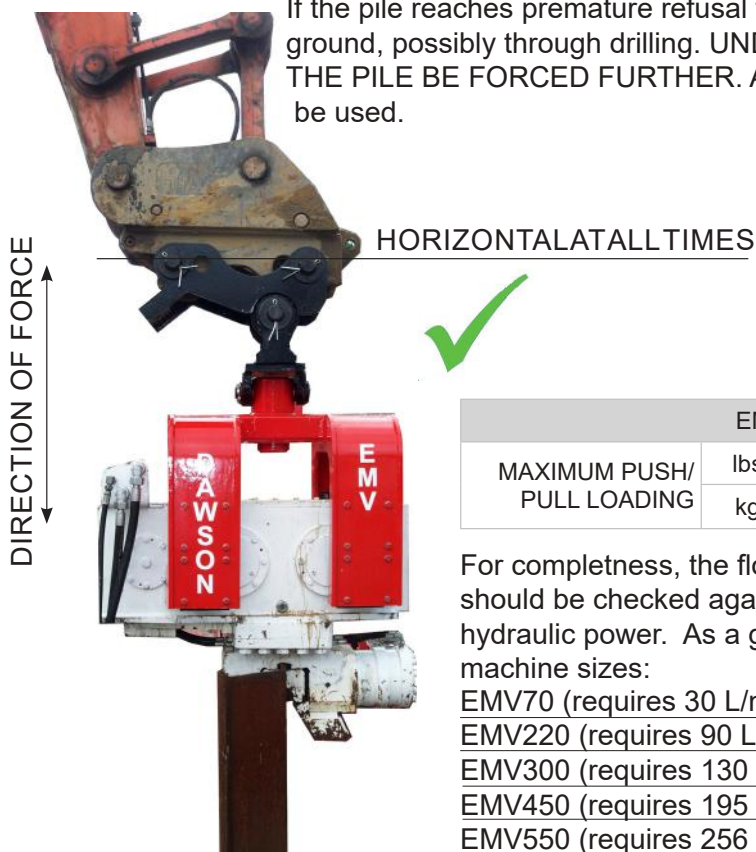

### WARNING!

The position of the quick hitch to the dipper arm.

The quick hitch should always be horizontal, with the direction of force being vertical as shown. Incorrect alignment could result in serious part failure and risk to life!

	EMV	70	220	300	450	550
MAXIMUM PUSH/ PULL LOADING	lbs	6,171	16,500	33,600	33,600	49,500
	kg	2,800	7,500	15,000	15,000	22,500

For completeness, the flow and pressure from the excavator to the EMV should be checked against the specification sheets to confirm adequate hydraulic power. As a guide the EMVs typically suit the following base machine sizes:

EMV70 (requires 30 L/min, 240 bar)	~ 5.5 - 17 t excavator
EMV220 (requires 90 L/min, 280 bar)	~ 7 - 18 t excavator
EMV300 (requires 130 L/min, 280 bar)	~ 13 - 25t excavator
EMV450 (requires 195 L/min, 270 bar)	~ 25 - 45t excavator
EMV550 (requires 256 L/min, 280 bar)	~ 30 - 55t excavator

## Daily Maintenance

Grease all grease points - Clamp Cylinder, Saddle Swivel, Dipper Pins

Check the screws, bolts, fitting etc. for tightness

Check hydraulic hoses for leaks

Check oil level in the excavator hydraulic tank

Check the gear oil level in the vibrator. The level must be halfway up the sight glass (change oil ever 50hrs).

Check lifting chain coupler and chain clamp for damage, wear and tear

For full details read operators instructions & spare parts manuals, available to view or download at [www.dcpuk.com](http://www.dcpuk.com)



**DAWSON**  
CONSTRUCTION PLANT LTD

Dawson Construction Plant  
Chesney Wold.  
Bleak Hall,  
Milton Keynes,  
MK6 1NE, England  
Tel: +44 (0) 1908 240300  
Fax: +44 (0) 1908 240222  
[www.dcpuk.com](http://www.dcpuk.com)



# how does the emv work?

Modern pile vibrators basically work in the same way. Pairs of high-speed contra-rotating eccentric weights are geared together so as to produce net vertical vibratory forces.

The vibrations produced are transmitted to the pile through a powerful hydraulic grip. Consequently the pile is vibrated at the same speed and displacement (or movement) as the gearbox itself. This vibration effect is transmitted to the pile tip where the surrounding soils become almost fluid like.

The fluidising effect on the soil permits particles to shuffle themselves around creating some spaces for the pile to move into. This combined with the weight of the pile and vibrator is adequate to push the pile into the ground.

Not all soil types will however fluidise. Clays soils are very cohesive and extremely dense by comparison to sands and gravels where vibrators work best. The dense clay soil does not allow soil particles to shuffle themselves around so no fluidising effect can occur. Also the ground effectively sticks itself to the pile and much of the power generated is lost in shaking the ground.

The EMV is particularly effective for its size and weight because it is able to utilise the crowd force available from the excavator to add further push force to the pile.

The gearbox in the EMV unit is driven by a hydraulic drive motor that receives hydraulic power from the excavators bucket ram circuit. Typically this circuit will be able to supply adequate working pressure but excessive amount of oil flow rate. The EMV has a built-in flow regulator that limits the oil flow rate supplied to the drive motor so that the gearbox can not be run too fast. This is essential to prevent excessive bearing loads and correct performance of the unit.

In addition, the flow regulator has a sequence valve built-in that will not allow the vibrator to run until adequate clamping force has been applied to the pile – an essential safety feature. This simplified hydraulic system enables simple installation and reliable performance.

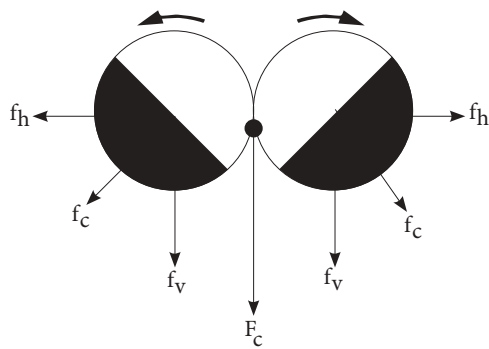
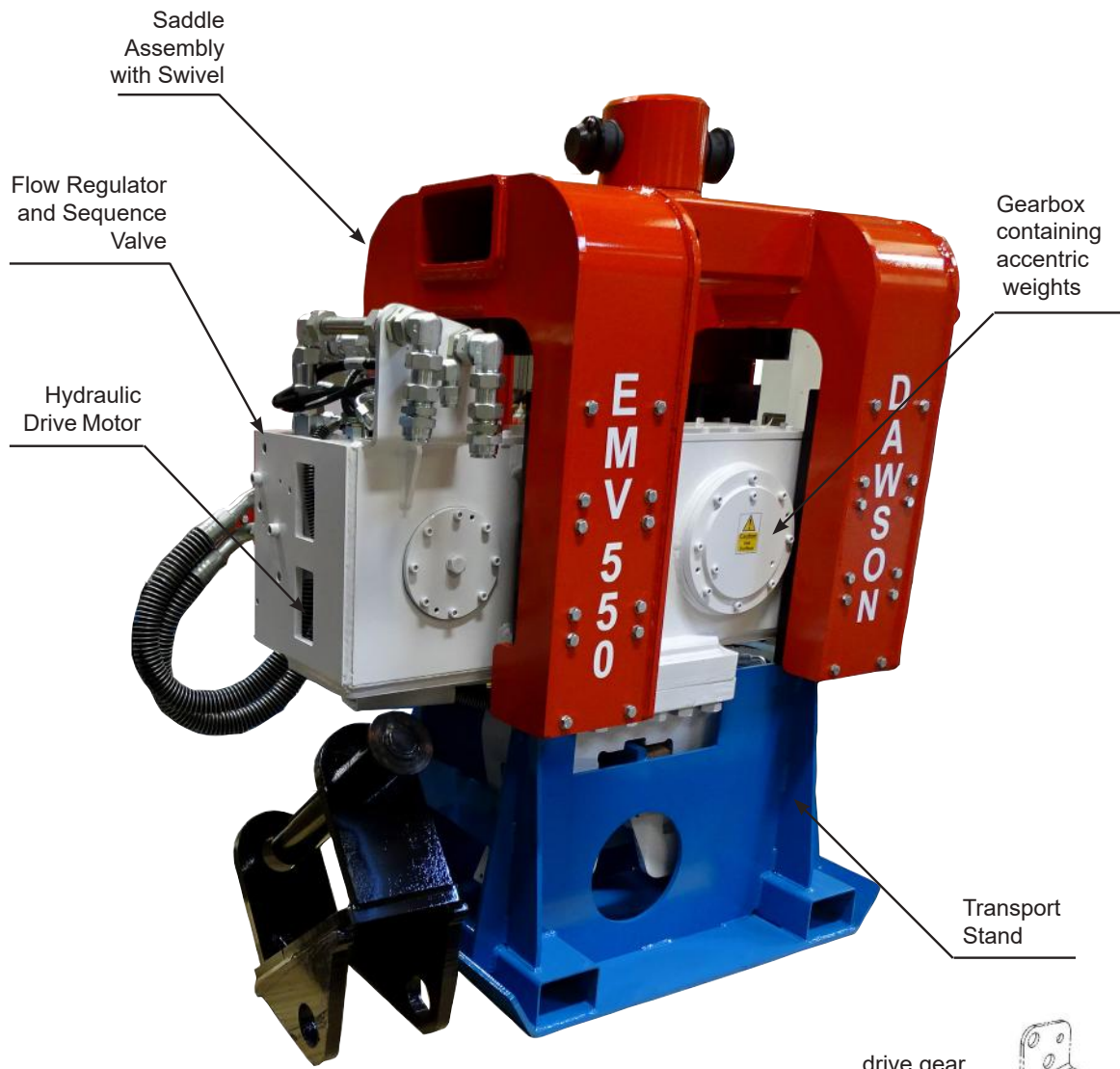

no.1

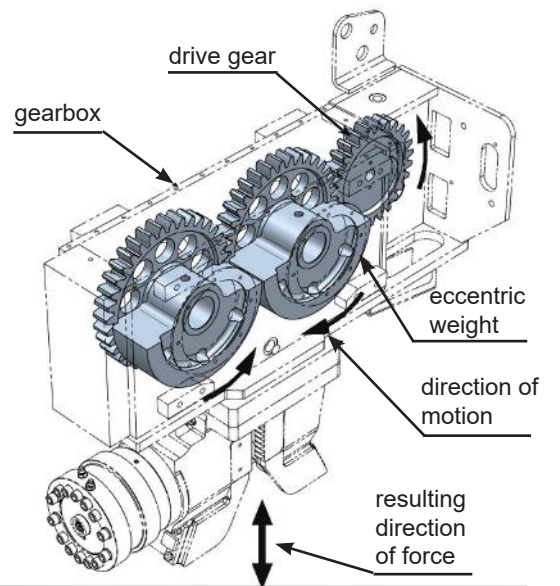

Motion of a pair of eccentrics

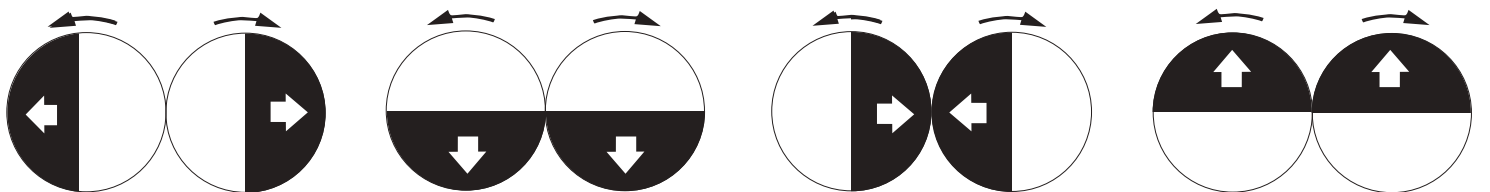

Corresponding Sinusoid



# mounting instructions

The excavator hydraulic power output must be matched to the requirements of the vibrator before installation. A standard excavator enquiry sheet is available for the user to complete prior to considering the suitability of the excavator for use with the EMV550.



## MOUNTING THE VIBRATOR

The vibrator is mounted in place of the excavator's bucket, and should be allowed to hang freely once installed. Remove the bucket prior to installing the EMV.

A shear pin is used to fix the vibrator to the boom via an adaptor bracket. Different adaptor brackets may be required for different excavators. Check this prior to the start of installation. If the excavator is fitted with a quick hitch it will either be necessary to remove it or purchase half a quick hitch and modify to suit the Dawson adaptor bracket.

Standard brackets are available for different machine size ranges. Typically, one of these brackets can be adapted to fit a variety of different pin sizes and dipper end widths by using a kit of bushes and spacers.

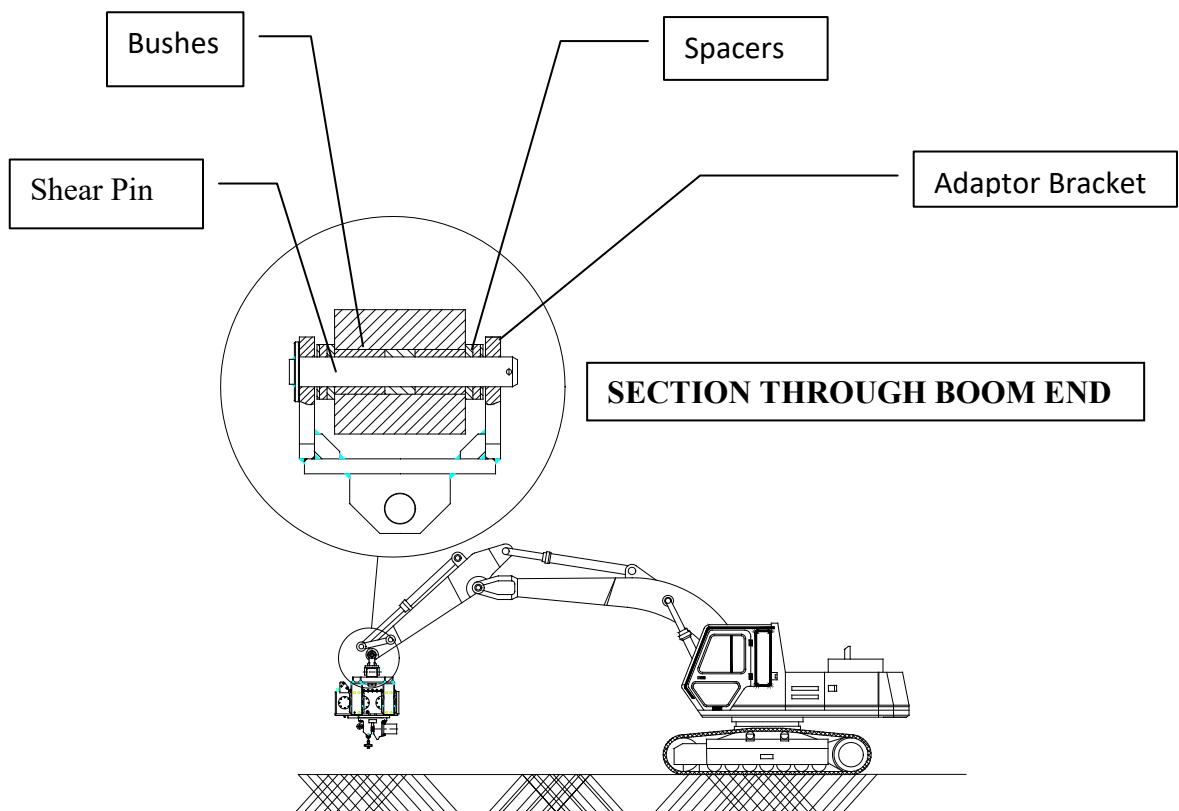

# continued - mounting instructions



## HYDRAULIC HOSES - LAYOUT & CONNECTIONS

The pressure line is usually connected to the bucket ram “extend” circuit and the return line to the bucket ram “retract” circuit. The third, and smaller, drain line is fed either directly back into the hydraulic tank on the excavator, or connected to the breaker circuit return line. Excavators will rarely have the same fittings as these on their bucket circuit so adaptor fittings must be used.



Ensure all hydraulic connections are clean prior to fitting and that no contamination is introduced into the hydraulic circuit during installation – this may cause internal component damage to the hydraulic system or faulty operation of the vibrator or excavator.

If quick release couplings are installed on the excavator they should be replaced. It is strongly recommended that quick release couplings are not used for this application. For permanent installation ball valves can be added to the excavator boom to ensure rapid changing between bucket and EMV hydraulic function. As the bucket ram is no longer in use, it should be retracted and fastened down.



**WARNING: THE DRAIN LINE MUST FLOW DIRECTLY TO TANK WITHOUT RESTRICTION. FAILURE TO DO SO WILL RESULT IN THE HYDRAULIC DRIVE MOTOR BLOWING ITS CASING SEAL OR FRONT CASING CASTING – THIS DAMAGE IS VERY COSTLY TO REPAIR.**

The EMV is fitted with a motor case blow-off valve. This valve is effectively a check valve that vents some oil to atmosphere should the motor case drain line pressure exceed approximately 6 bar. It is not a pressure protection valve and is intended only as an early warning valve, giving a visual signal that something is wrong. Any sign of this and use of the EMV should be halted immediately and the cause investigated.

The blow-off valve does not guarantee the motor will be protected in all circumstances!

# operating instructions



## PREPARATIONS - BEFORE DRIVING / EXTRACTING PILES

It is the excavator operator's responsibility to ensure that the equipment is functioning and performing correctly and that the EMV method of piling is implemented efficiently.

In order to meet this responsibility please note the following points:

- a. Bundles of sheet piles should be set out on the job site so as to minimise the amount of handling and travelling required with the EMV.
- b. Ensure that all piles have  $\text{Ø}40\text{mm}(\text{Ø}1\frac{1}{2}\text{''})$  holes cut in them approximately 250mm(10") down from the top edge and central prior to commencement of the piling operation.
- c. Allow the excavator engine to warm up, particularly in temperatures below minus 10°C and warm the excavators hydraulic system by, for example, tracking backwards and forwards – this avoids the EMV's blow-off valve spitting oil on initial start-up.
- d. Before work commences slowly operate the bucket ram lever in both directions. It is particularly important that the vibrator is allowed to run freely for approximately 30 seconds, this allows the gearbox oil to reach all the necessary lubricating points.
- e. Review section "Basic Safety Points" in this manual before starting work.
- f. Review section "Daily Maintenance" before taking the equipment into service.
- g. It is particularly important that you make sure that during a piling operation the vibrator is kept directly above and in line with the pile, otherwise the piling energy is transferred to the excavator arm and causes unnecessary wear and may lead to pile damage.



## DRIVING PILES

- a. Ensure that all safety procedures and maintenance has been carried out before starting the excavator – see above.
- b. Ensure that it is safe to move the dipper arm. Release the stand from the jaws of the vibrator by operation of the retract bucket ram control function in the cab. Manoeuvre the vibrator above one end of the pile to be pitched, so that there is enough distance to allow safe insertion of the lifting chain through the hole at the top of the pile.
- c. Manoeuvre the vibrator above one end of the pile to be pitched, so that there is enough distance to allow safe insertion of the lifting chain through the hole at the top of the pile.
- d. Check which way around the pile has to be lifted before inserting the lifting chain – was the previous pile pitched left or right handed? Insert the lifting chain correctly (no twists, knots etc) through the lifting hole in the pile and finally with the chain clamp. Allow enough free chain length for the pile to rotate to vertical during the lifting process without jamming against the underside of the clamp body. If this happens the chain will be overloaded, may subsequently break and allow the pile to fall – this is a sever hazard to all site personnel and must be avoided at all times. Do not allow too much chain so that the top of the pile hangs too far away from the clamp when it is raised to the vertical – this will make it difficult to engage the pile in the clamp.
- e. Clear all personnel standing in the **High Risk Area** and lift up the pile until it just hangs freely off the ground.
- f. Lower the pile slowly so that the pile can be correctly inserted into the clamp. Once firmly inserted, close the jaws.
- g. Manoeuvre the pile to the insertion point and push the pile slowly into the ground. Plumb the pile and ensure all personnel are out of the **High Risk Area**.

# continued - operating instructions

- h. Start the vibrator and adjust (crowd) the hydraulic rams so that the vibrator is level and always sits directly on top of the pile as it goes into the ground. Do not over push the vibrator - stop pushing when the gearbox starts to vibrate against the rubber stops on the underside of the saddle (the deflection is 146mm (5.75")).
- i. When the pile has reached the required depth turn the vibrator off by returning the control lever to the central position and allow all vibrations to stop. Release the hard jaws from the pile by slowly operating the control lever in the opposite direction. Do not operate the control lever from one extreme position to the other whilst the EMV is running – it will cause hydraulic system pressure spikes to occur.
- j. Remove the chain clamp and lifting chain from the pile lifting hole.
- k. Repeat steps c-j to continue.
- l. When piling progress is less than 100mm/min (4ins/min) release ground resistance by augering or by water jetting. Under no circumstances should the pile be forced any further.



## EXTRACTING PILES

- a. Ensure that all safety procedures and maintenance has been carried out before starting the excavator.
- b. Ensure that it is safe to move the dipper arm. Release the stand from the jaws of the vibrator by operation of the retract bucket ram control function in the cab. Manoeuvre the vibrator above one end of the pile to be extracted so that there is enough distance to allow safe insertion of the lifting chain through the hole at the top of the pile. Confirm suitable hole in pile.
- c. Insert the lifting chain correctly (no twists, knots etc) through the lifting hole in the pile and secure with the chain clamp. Allow enough free chain length for the pile to rotate to horizontal during the lowering process without jamming against the underside of the clamp body. If this happens the chain will be overloaded, may subsequently break and allow the pile to fall – this is a severe hazard to all site personnel and must be avoided at all times.

Under no circumstances should a pile be pulled using the lifting chain only.

- d. Clamp the vibrator onto the pile head ensuring that it is level. Ensure all personnel are out of the **High Risk Area**.
- e. Start the vibrator and allow the soil to loosen around the pile. Start to lift up the pile. Ensure the pile clutches are not rubbing together. Pay attention to the distortion of the rubber sandwich mounts - under no circumstances should these mounts be allowed to deflect by more than the stipulated amount shown on Figure 1 in section 2.0. Reduce the extraction force to continue pulling. Continue extracting the pile until the pile foot is almost extracted. Stop vibration at this point and carefully pull the pile out the remaining short distance.
- f. Move the pile to a suitable area, and place the pile on the ground. Ensure that all personnel are out of the **High Risk Area**.
- g. Hold the pile on the ground and release the jaws. Raise the vibrator off the pile slowly ensuring that there is no snatch on the lifting chain. Slowly lower the pile towards the ground.
- h. Remove the chain clamp and lifting chain from the pile lifting hole.
- i. Repeat steps c-h to continue.



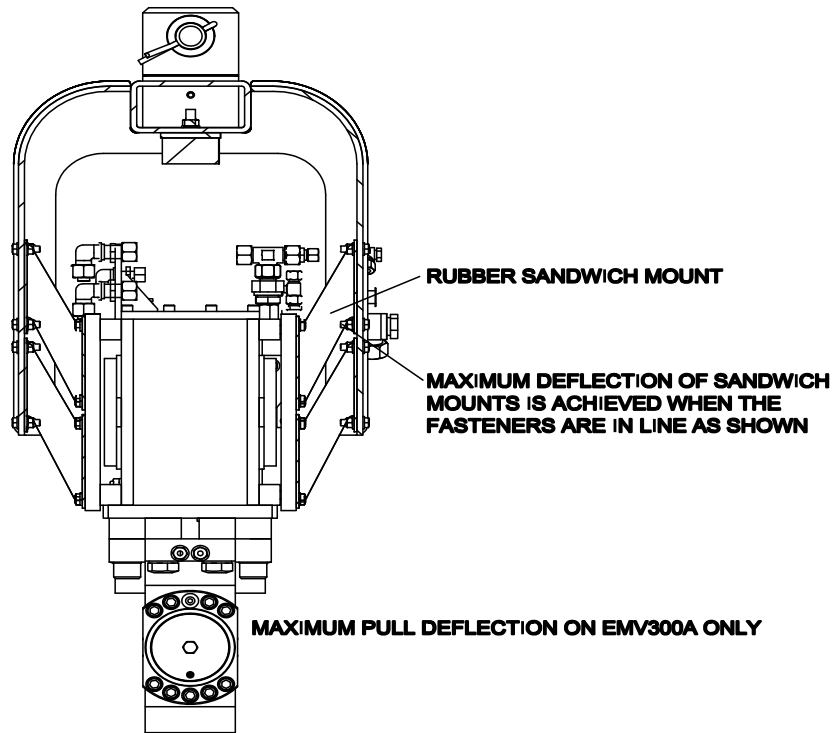

Maximum deflection of sandwich mounts is achieved during extracting when the gearbox casing hits the safety stops (140mm). When driving piles a maximum deflection of 146mm can be achieved. This is when the top fasteners are inline with the lower.

# operating instructions driving piles (quick reference illustrations)

The illustrations below are to show visually a simplified version of the operating instructions given in part 5.2/5.3, driving / extracting piles. 5.1 preparation before driving / extracting piles must be read before these illustrations.

Set out bundles of piles on the job sites to minimise the amount of handling time and travelling.

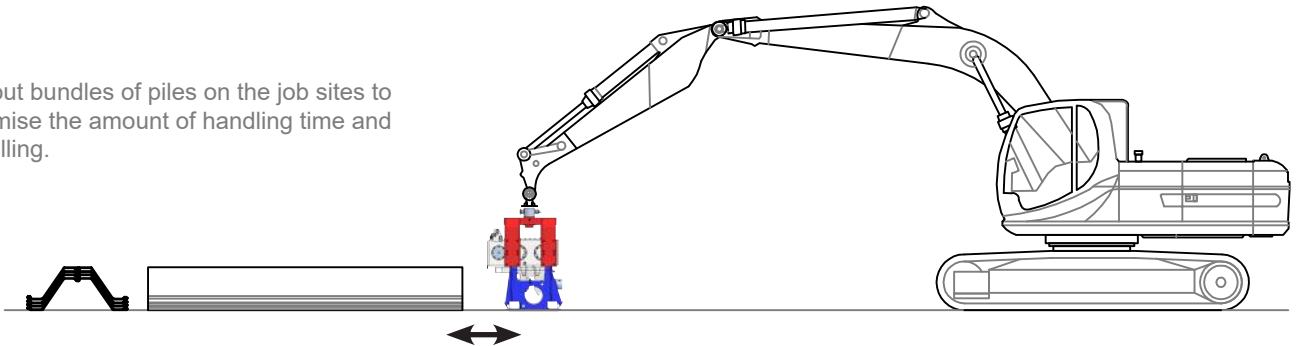

Ensure it is safe to move the dipper arm. Release the stand from the jaws of the vibrator by operating the retract bucket ram control function in the cab.

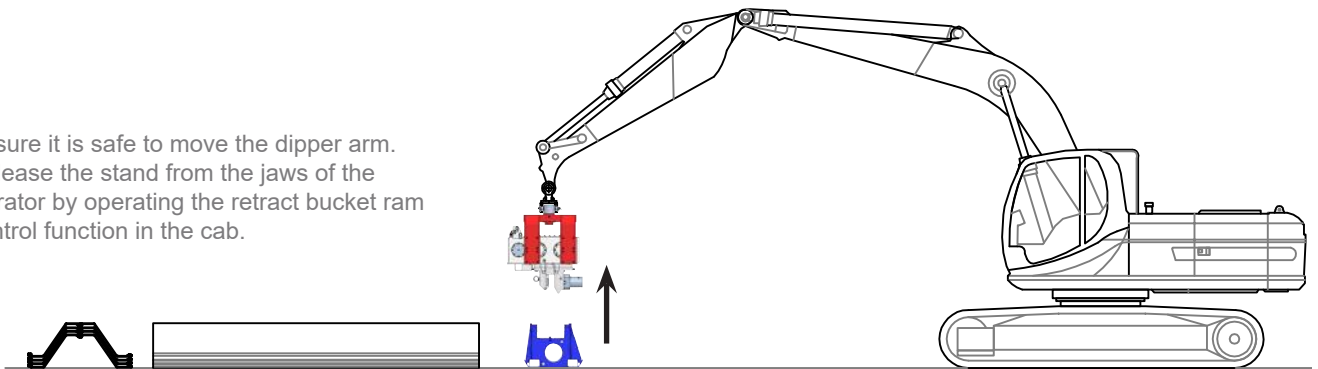

Move the vibrator to the pile to pitched. Leave enough room for the safe insertion of the lifting chain.

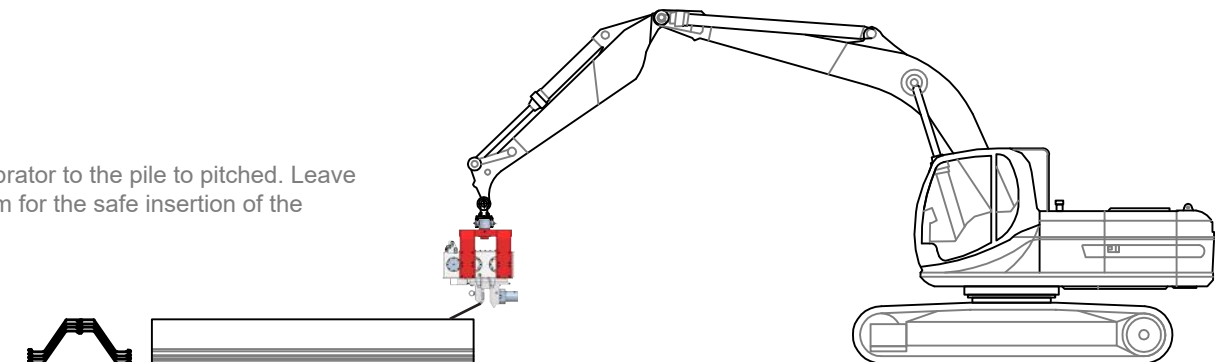

Insert lifting chain correctly to safety standards  
**Clear all personnel standing in high risk area.**  
Lift pile up till free hanging above ground..

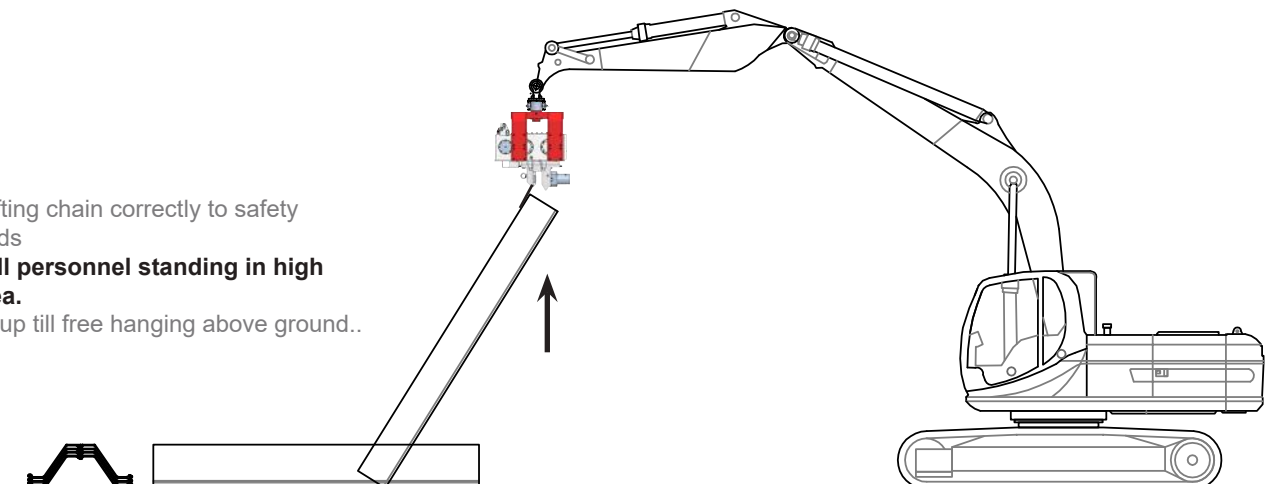

Lower the pile slowly so that the pile can be correctly inserted into the clamp. Once firmly inserted, close the jaws.

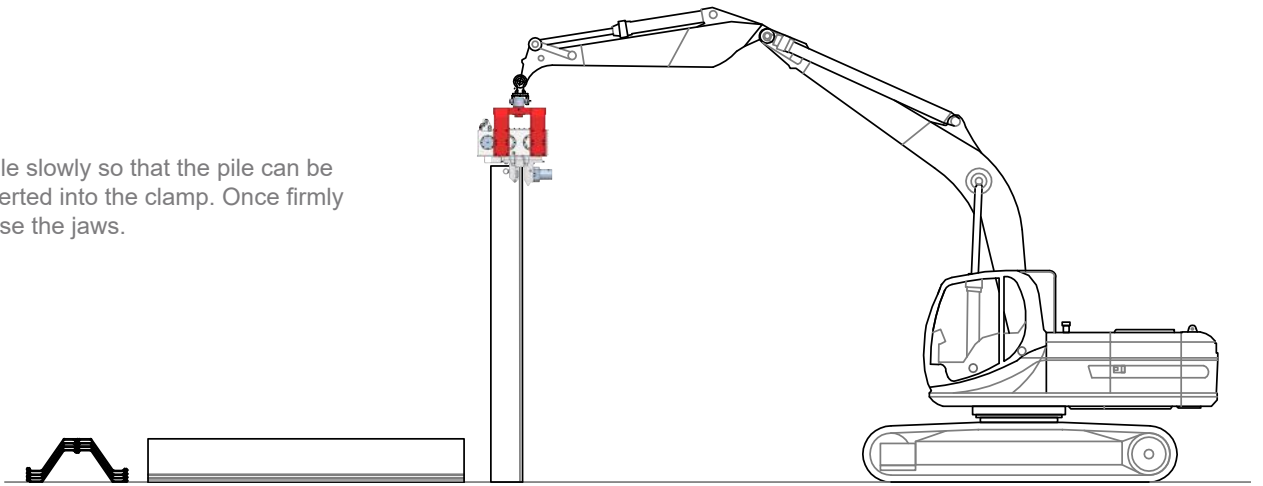

Manoeuvre the pile to the insertion point and push the pile slowly into the ground. Plumb the pile then ensure all personnel are out of the High Risk Area.

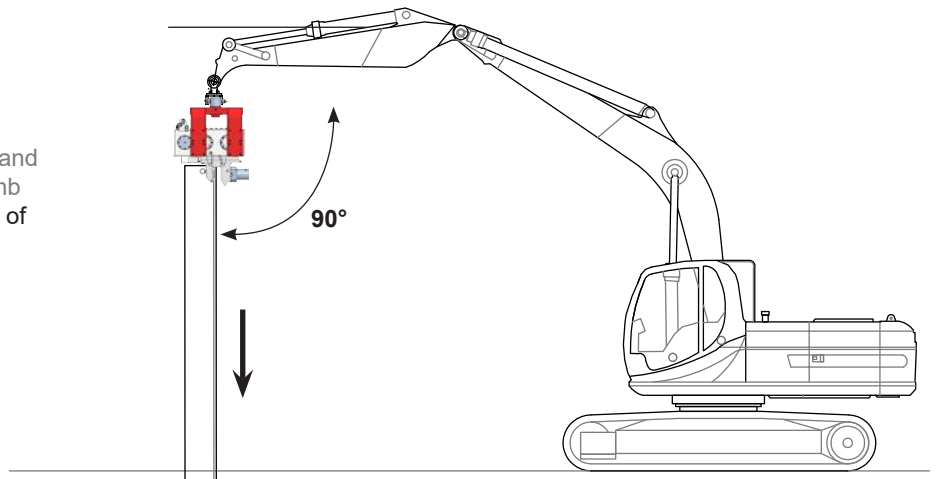

Start the vibrator and adjust (crowd) the hydraulic rams so that the vibrator is level and always sits directly on top of the pile as it goes into the ground.

When the pile has reached the required depth turn the vibrator off by returning the control lever to the central position and allow all vibrations to stop.

Remove the chain clamp and lifting chain from the pile lifting hole.

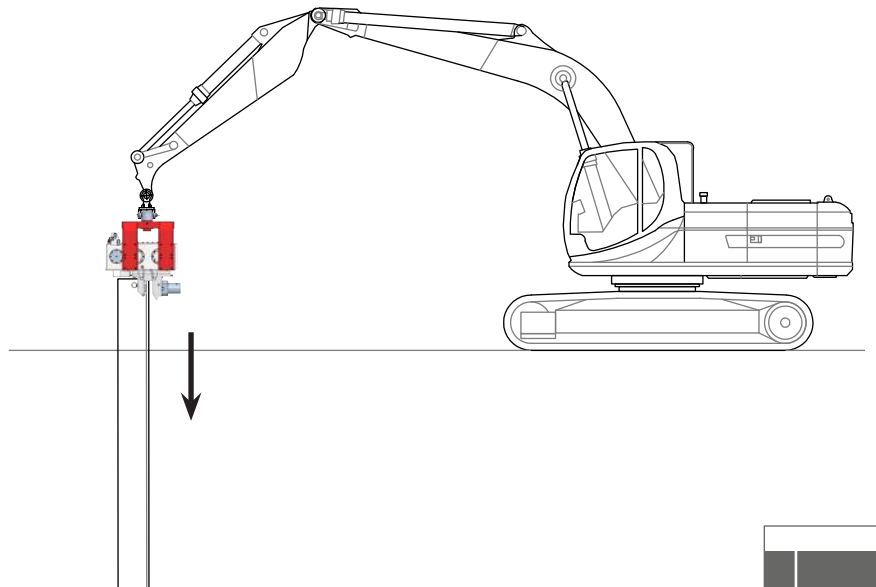

# operating instructions - extracting piles (quick reference illustrations)

The illustrations below are to show visually a simplified version of the operating instructions given in part 5.2/5.3, driving / extracting piles. 5.1 preparation before driving / extracting piles must be read before these illustrations.

Ensure it is safe to move the dipper arm. Release the stand from the jaws of the vibrator by operating the retract bucket ram control function in the cab.

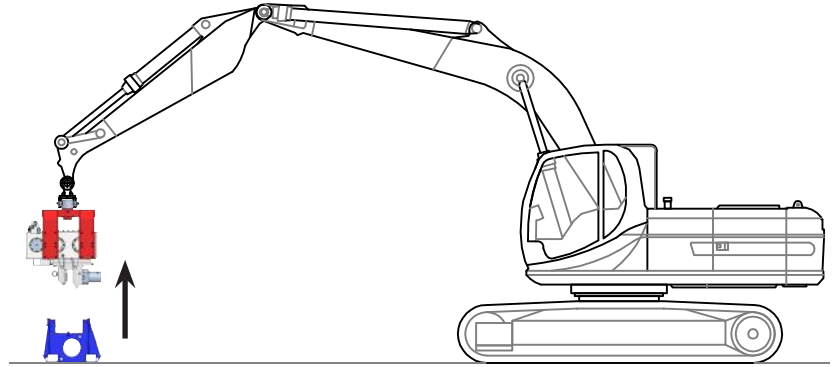

 Move the vibrator to the pile to be extracted. Leave enough room for the safe insertion of the lifting chain. **Clear all personnel standing in high risk area.**

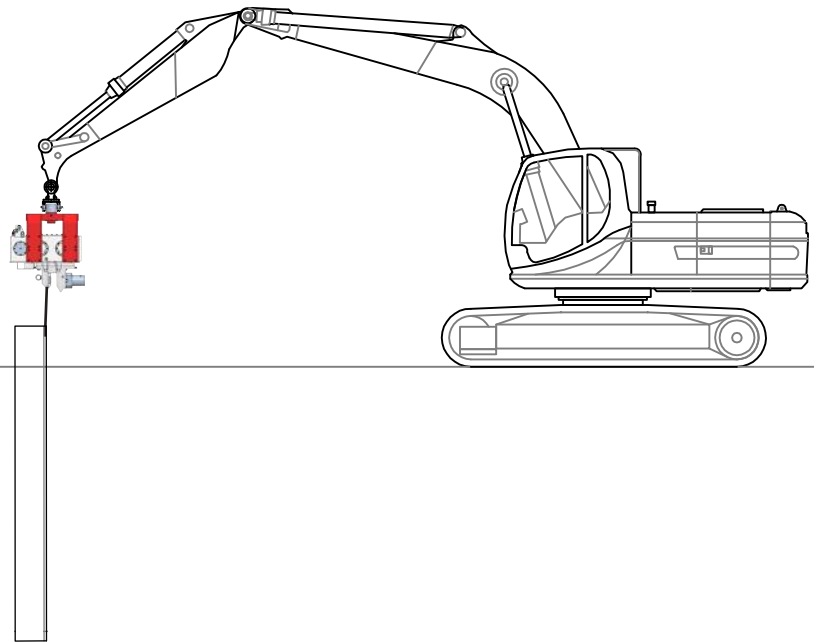

 Under no circumstances should a pile be pulled using the liftin chain.

Clamp the vibrator onto the pile head ensuring that it is level.

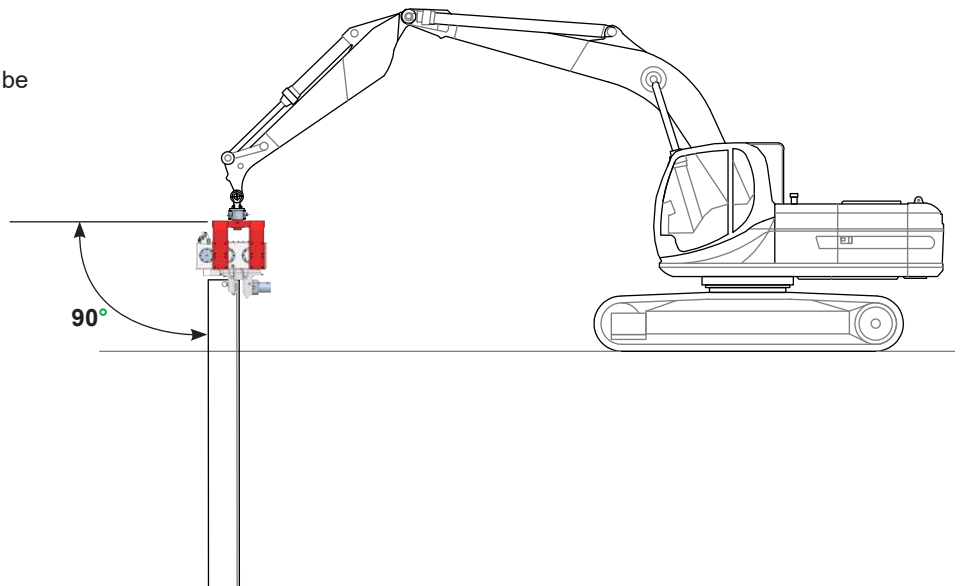



Start the vibrator and allow the soil to loosen around the pile. Start to lift up the pile. Ensure the pile clutches are not rubbing together. Pay attention to the distortion of the rubber sandwich mounts - under no circumstances should these mounts be allowed to deflect by more than the stipulated amount shown on Figure 1 in section 2.0. If these mounts are deflected by more than the specified amount on the EMV reduce the extraction force to continue pulling. Continue extracting the pile until the pile foot is almost extracted. Stop vibration at this point and carefully pull the pile out the remaining short distance.

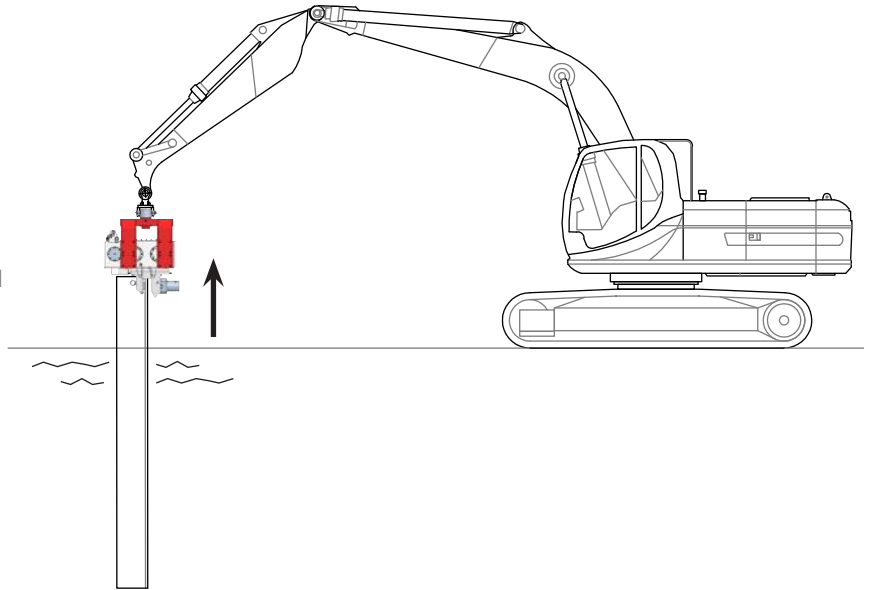

Move the pile to a suitable area, and place the pile on the ground. Ensure that all personnel are out of the High Risk Area.

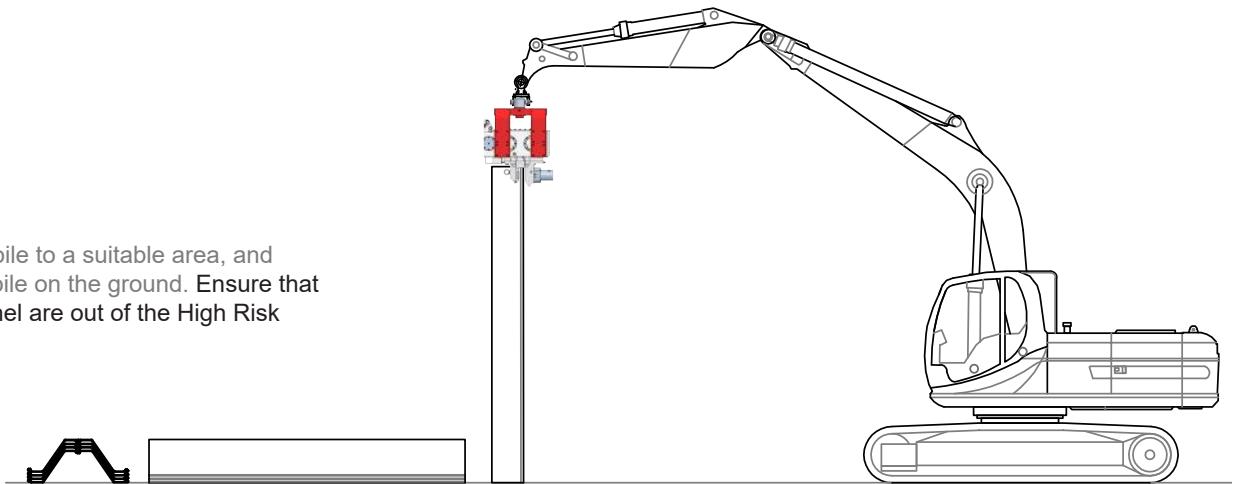

Hold the pile on the ground and release the jaws. Raise the vibrator off the pile slowly ensuring that there is no snatch on the lifting chain. Slowly lower the pile towards the ground.

Remove the chain clamp and lifting chain from the pile lifting hole.

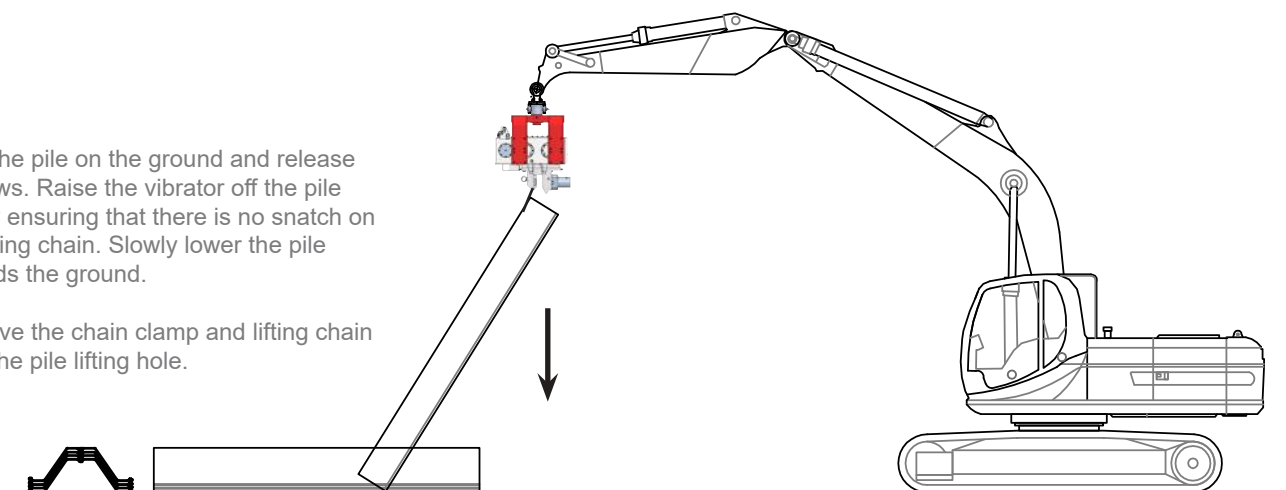

# recommended excavator positions (quick reference illustrations)

These illustrations represent the recommended working, transport and resting positions for your Dawson EMV attachment when used with an excavator.

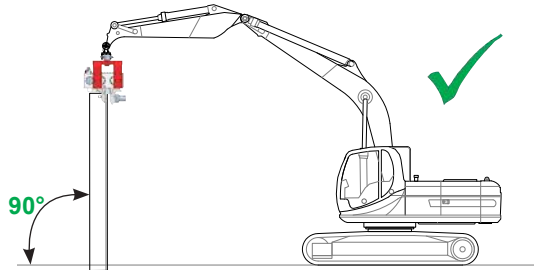

**Recommended: Starting Position**  
Position the pile vertically in desired location and begin drive / extracting.

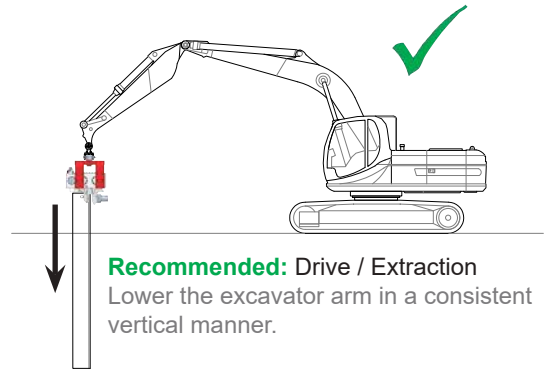

**Recommended: Drive / Extraction**  
Lower the excavator arm in a consistent vertical manner.

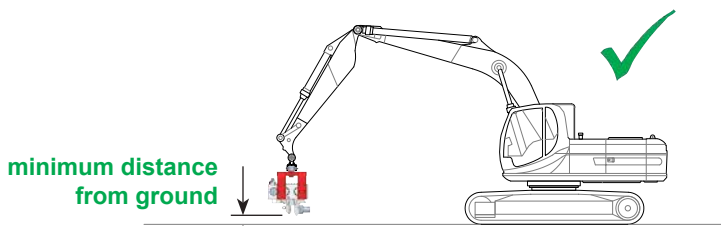

**Recommended: Transport Position**  
Lift the Vibro off the ground during transport on the job site. Keep Vibro as low as possible.

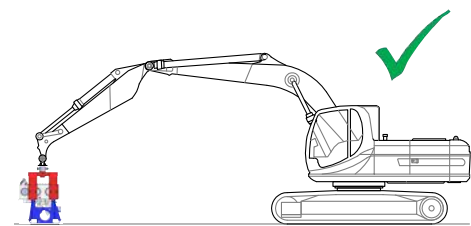

**Recommended: Resting/Parting Position**  
Park the excavator with the vibro in its stand.

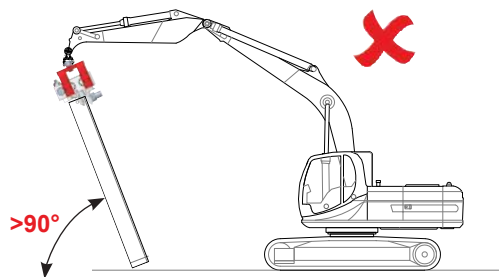

**Avoid: Driving / Extraction Position**  
Avoid any driving / extrating position that is not vertical. Vibro will become unstable and not easily controlled

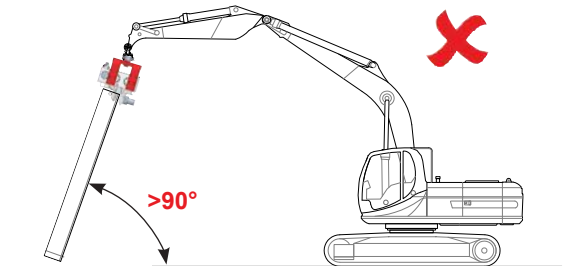

**Avoid: Driving / Extraction Position**  
Avoid any driving / extrating position that is not vertical. Vibro will become unstable and not easily controlled

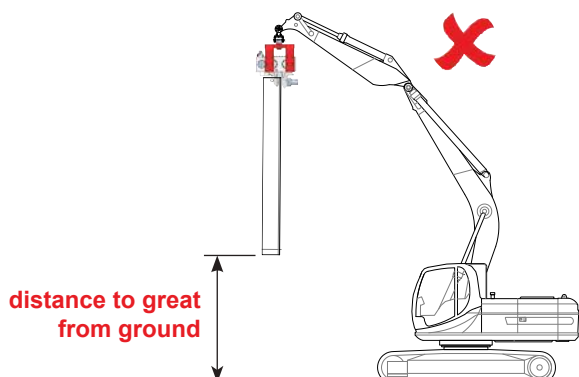

**Avoid: Transport Position**  
When Transporting the pile on the job site do not allow the pile to swing in an uncontrolled manner. Damage can occur to the vibro and excavator.

**Avoid: Resting/Parting Position**  
Avoid parking the excavator with the Vibro in a suspended position.



The Excavator Mounted Vibrators have been designed to give years of trouble free service. Providing the equipment is treated with respect and the basic maintenance procedures are adhered to there will be little work additional work required.

The most important points are correct installation on good quality excavators, cleanliness when connecting to the excavator's hydraulic system and regular gearbox oil changes using appropriate oils - again cleanliness is paramount.

Visual inspection of the EMV by a competent person on a daily basis and before being taken into service can prevent many potential problems from occurring. Ensure that lifting accessory test certificates are correct and valid at all times.

- All service and maintenance work must be carried out by qualified personnel using original Dawson parts. The use of other parts will invalidate the whole warranty for the equipment.
- The equipment should be inspected at ground level only and should be positioned so as to be stable at all times.
- Secure the equipment against unexpected starting during the maintenance process.
- The equipment should be inspected by a Dawson technician or by one of their approved distributors once a year or every 1000 working hours.



## DAILY MAINTENANCE

- a. Grease the two grease points on the EMV550– one on the Saddle Swivel and the other on the side of the Clamp Body. Two or three pumps with a molybdenum-based grease will be adequate.
- b. Check machine labelling.
- c. Check visible screws, bolts, fittings etc for tightness.
- d. Visually inspect all hydraulic hoses and fittings for leaks or damage.
- e. Check the gear oil level in the vibrator. The level must be half way up the sight glass.
- f. Inspect the lifting chain and chain clamp for damage. The chain should be in good order, free from any structural damage or permanent deformation of any kind. The chain clamp should also be free from any structural damage and its correct operation and safe function should be checked by depressing and releasing several times – any binding or hesitancy with its operation should result in it being changed for a new certified item. The chains Coupler and anchorage point should be in good order showing no signs of damage, wear or cracking.

Remember if in doubt change it – lifting chains in the UK are required to have a thorough examination by a competent person at intervals not exceeding 6 months. Any local/national requirements must be adhered to!

- g. Inspect the condition of the Hard Jaws. To be acceptable these should look to be in almost as new condition. The teeth on these pads have some flats on them when new (approximately 1mm). Over time they will round off, flatten out more and even become chipped. If not changed when require they will loose their grip on the pile during driving and certainly during extraction. Besides causing a reduction in performance this can become a safety hazard. We define the following wear limit:

**Hard Jaw Wear Limit - 90% of all teeth on any hard jaw should make contact with the pile and 80% of all teeth should have points with flats no greater than 3mm.**

### Changing the Hard Jaws – Static Side

Remove the Cap Screw that hold this jaw in place. Tap out the old jaw and clean/inspect the clamp body seating area to ensure the faces are in good order. Slide in the new jaw and check that it is a snug fit – the

# continued - maintenance

jaw should not move up and down. Fit the Cap Screw and tighten using a hexagonal wrench. Remember to install the washers on these screws.



## Changing the Hard Jaws – Moving (Cylinder) Side

Release the 8 off Cap Screws that hold the Clamp Cylinder in place and remove the Clamp Cylinder. Undo the two clamp supply hoses, carefully marking them to ensure correct re-assembly. Once removed, unscrew the round Hard Jaw counter-clockwise and replace with a new one using a new O-ring. Ensure the Jaw is fully tightened on the Clamp Cylinder piston rod so that the O-ring is no longer visible. Inspect the bronze Guide Bush inside the Clamp Body whilst the cylinder is out – check the grooves in the front area of the bush and the condition of the bore. Replace the bush if badly worn.

Assemble the Clamp Cylinder back into the Clamp Body, fit the clamp hoses then fit and tighten the Cap Screws using the hexagonal wrench. Ensure the clamp functions correctly after completing the work.

- h. Inspect the rubber Sandwich Mounts (Elastomers) for wear or damage. Wear is typified by splitting/tares. This usually occurs in the rubber adjacent to the bonded steel plates and is usually a result of fatigue in the material over a long period of time. Cracking/softening may occur but this is usually associated with long term exposure to sunlight or exposure to petroleum based products. As a general rule change the Sandwich Mount if any single tare or split exceeds 40mm (1½”) or if the rubber has become contaminated.
- i. Check the overall condition of the Swivel Assembly. Check that the Lifting Bolt and Nut (that are the centre piece of this assembly) only allow rotational movement with minimal axial movement. Excessive axial movement will allow the assembly to rattle around, make more noise and cause in turn more wear. If the axial play exceeds 1mm it will be necessary to tighten the nut. To do this remove the coil/spring pin with a punch and hammer, tighten the nut further and drill and pin it in the new position.
- j. Check the condition of the boom Adaptor Bracket, Shear Pins, Spacers and Bushes. The whole assembly should be relatively tight with minimal play in the components. The bracket needs to be able to float a little from side to side – as much as 5/10 mm is acceptable. The pins and bushes should however be little more than a running fit – clearances of more than 0.5mm would be considered excessive.

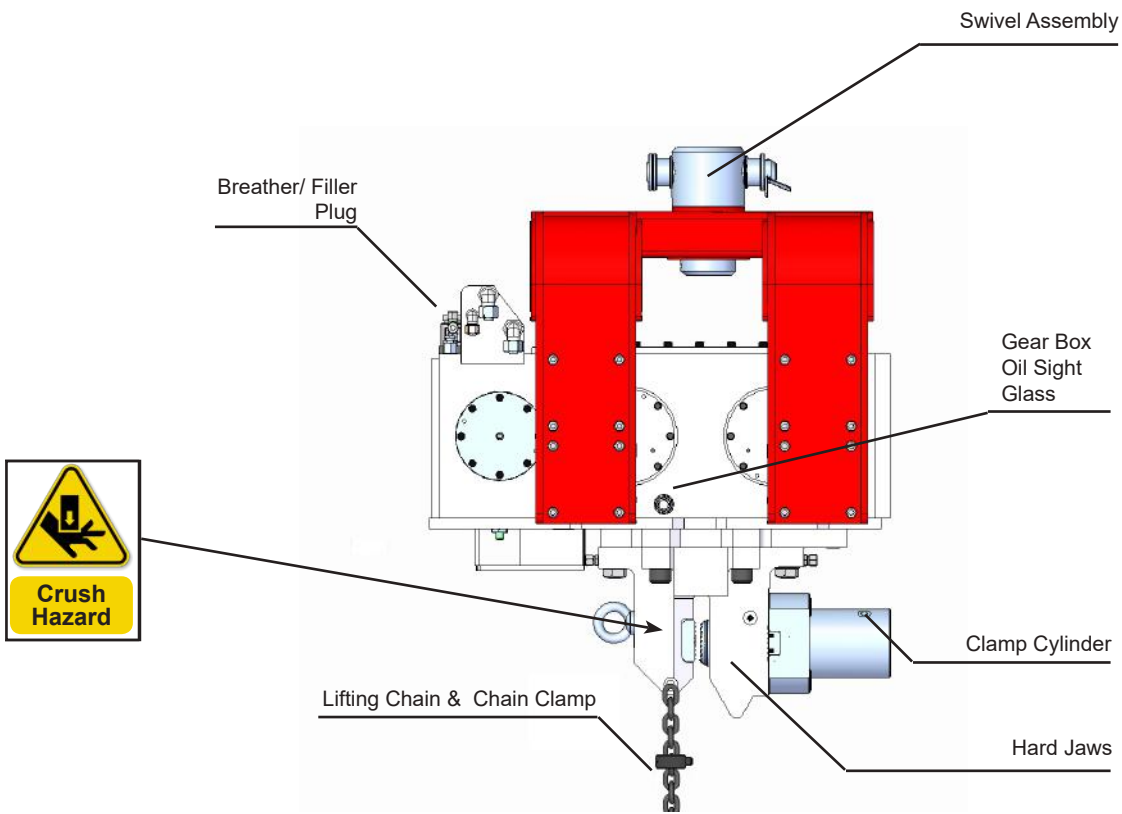

		<b>109</b> dB
Ear protection must be worn		
<b>MAX. LINE PULL</b> <b>15,000Kg</b>		
<b>MAX. PILE WEIGHT</b> <b>800Kg</b>		

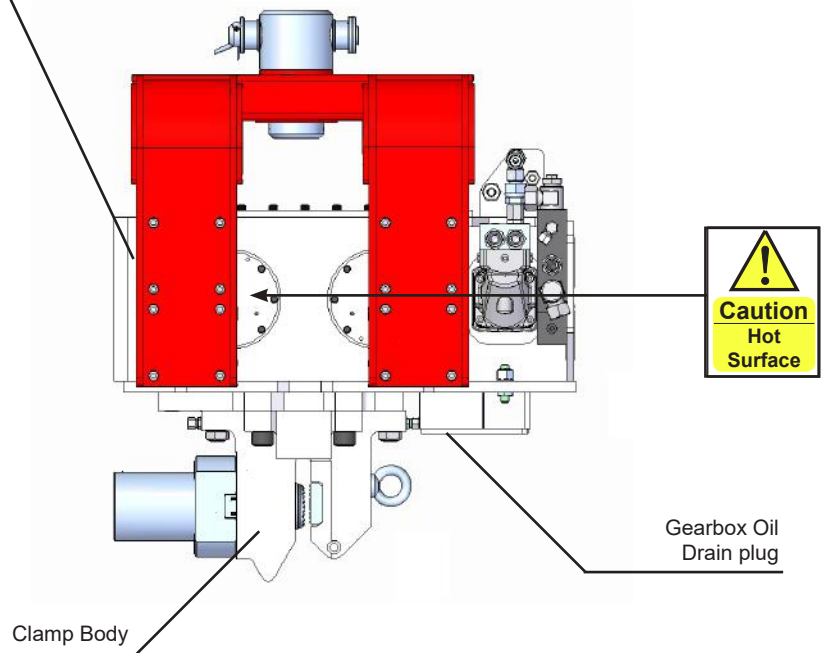



**EVERY 50 WORKING HOURS**

Change the oil in the vibrator gearbox. Remove the Drain Plug from the bottom of the gearbox and the Breather/Filler Plug from the top. Allow the oil to drain out completely into a suitable container – this is best done at the end of a shift when the oil is relatively warm and thin. Replace the Drain plug and fill with new clean oil through the Breather/Filler hole until the oil level in the gearbox is approximately half way up the sight glass – this is approximately 5.5 litres (0.66 US gallons).

Re-fit the Breather/Filler Plug using a new seal and tighten.

The old oil must be taken to a certified waste disposal centre or handed over to a certified waste disposal contractor.

Generally any good quality mineral based gear oil in the class API GL-5 with viscosity class SAE 75W/90 will be suitable. Alternatively, in hotter climates fully synthetic oil of the same classification may be used. For example:

Manufacturer	Mineral Oil Reference	Synthetic Oil Reference
BP	ENEGEAR HT 75W/90	
MOBIL		MOBILUBE 1 SHC
CASTROL		SAF-EXB
ELF	TRANSELF B 75W/90	TRANSELF TR2 75W/80
TEXACO	GEARTEX EPC80W/90	GEARTEX 5S 75W/90

Note: Maximum ambient operating temperature for the unit +40°C  
Minimum ambient operating temperature for the unit -20°C



**EVERY 100 HOURS**

It is recommended that the unit be inspected and serviced by the manufacturer. Apart from undertaking to do the relevant preventative maintenance work and checks as described above Dawson will inspect the structural integrity of the equipment and ensure there are no safety related matters that may go unchecked. Bearings and gears will also be inspected to check for signs of unusual wear or potential problems. In some countries it is a requirement by law that the unit be inspected by qualified personnel.

# troubleshooting

Please ensure that troubleshooting, inspection work and repairs are undertaken by suitably qualified personnel. Training can be carried out by the manufacturer or by your local approved Dawson distributor. The following guidelines are intended to assist with basic diagnostics and are not intended to be a definitive list – it assumes the inspector has a basic understanding of servicing techniques associated with this type of equipment. Work should not be undertaken by a novice without adequate supervision.



## EMV CLAMP DOES NOT CLOSE

Check that base machine hydraulics lines are correctly connected. Operate control lever in both directions to check flow directions.

Remove the check valve cartridge from the rear of the clamp cylinder and inspect for contamination or damage. The poppet inside the cartridge should move freely. If in doubt replace and use new seals.

Independently check the operation of the clamp cylinder with it removed from the hydraulic circuit. This should only be carried out by a competent person.

Remove the cylinder and inspect for mechanical damage inside the clamp or inside the cylinder.



Pilot Operated  
Check Valve

Pilot Operated  
Check Valve

# continued - troubleshooting



## **EMV CLAMP CLOSES BUT THE UNIT WILL NOT VIBRATE**

Check the base machine operating pressure and flow rate. If the pressure output of the excavator is too low the EMV will not run at all. This is because the sequence valve pressure setting has to be overcome before oil can pass to the drive motor.

Check the sequence valve setting by installing a pressure test gauge in the clamp close line and monitoring the pressure at which the valve opens. Ensure this is set to 165 bar.

Damaged sequence valve – remove and inspect but replace if in doubt using new seals.

Motor failure or gearbox problem. Try connecting the two main oil supply lines directly to the hydraulic motor ports and running the unit with low engine speed – effectively low oil flow rate. Caution - it will be easy to over-speed the motor in this case because the flow regulator is now out of the circuit.

If the unit does not vibrate either the motor has become damaged or there is a fault with the gearbox. Check the oil level in the gearbox to see that it has not become filled with hydraulic oil from the motor shaft seal – in this case the unit usually runs very slowly unless metal fragments have become entrapped in the transmission system as result. Consult the manufacturer.

Remove the motor from the gearbox and test.

As a last resort take the saddle assembly off the EMV and remove the gearbox lid for an internal inspection. The gears, shafts and bearings should rotate freely.

**Caution - pay attention to trapping body parts in the mechanism during inspection!**



## **UNIT WILL NOT RUN AT THE CORRECT SPEED - "JUMPS AROUND" OR SPEED FLUCTUATES**

Check that the base machine hydraulic output complies with the minimum specified for the unit. Specifically check with the excavator supplier/manufacturer what system pressure is available on the bucket ram circuit at 90 l/min.

Check the setting of the flow regulator to ensure adequate flow is reaching the drive motor.

Check the sequence valve pressure setting. If this setting is too close to the operating pressure the EMV will speed up then slow down, speed up then slow down etc.

Check the gearbox oil level. If it is much higher than the sight glass the motor shaft seal has probably blown.



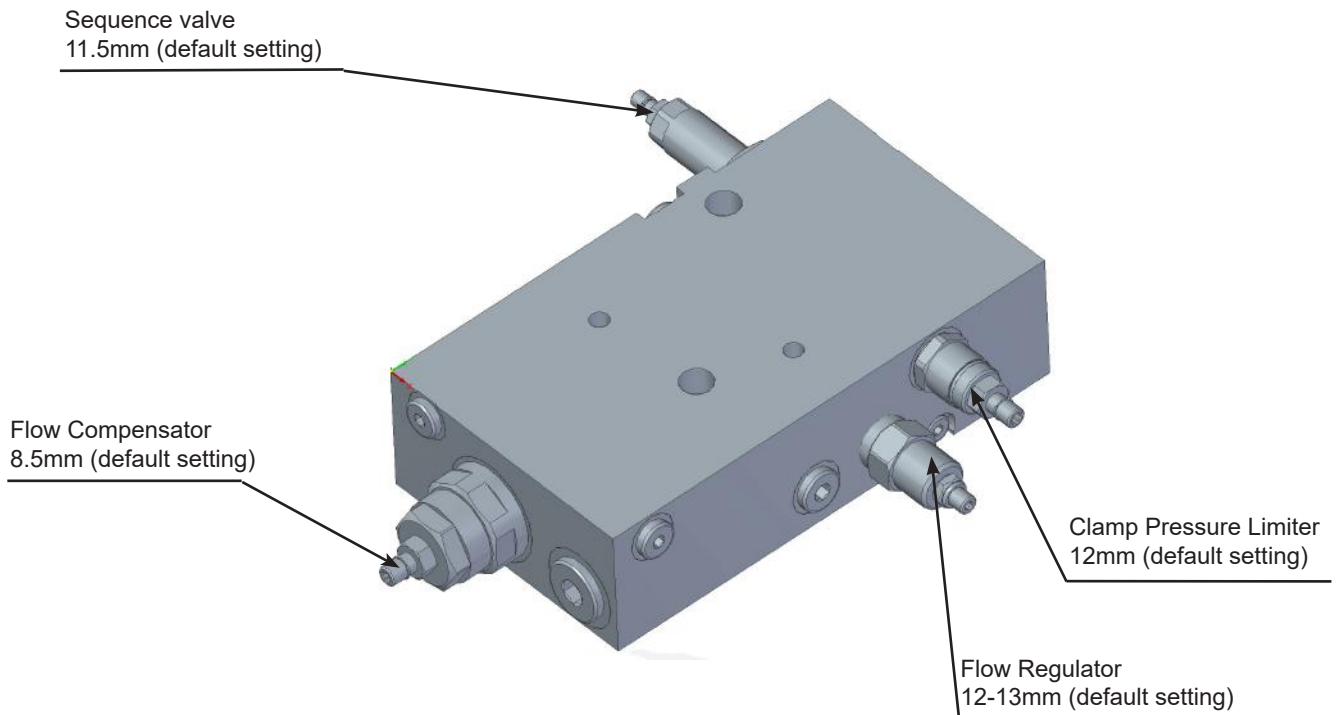

**OIL BLOWING OUT OF THE MOTOR BLOW-OFF VALVE**  
 Drain line restricted or blocked – stop work immediately.

Motor Blow Off Valve

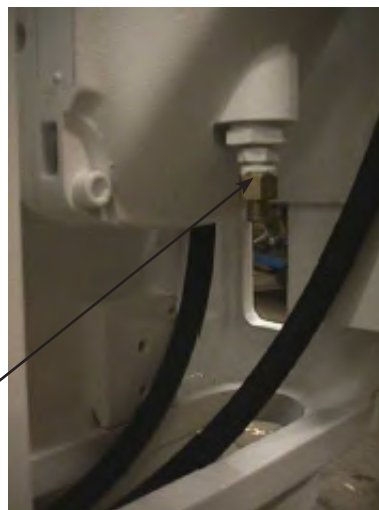

Check the drain line hose for obvious restrictions at fittings, filters etc.

Check the drain hose for damage – look carefully as the bore of the hose can be crushed even when the outside of the hose looks to be in good order at a casual glance.

Check the drain hose point of entry into the base machine hydraulic oil system – it is always best to run it directly to tank.

Do not work with quick disconnects as they can cause restriction

Drain line being pressurised – check that the line is not connected to a supply line e.g. the pressure line from a breaker circuit.

# continued - troubleshooting

Long drain hose or the hose bore too small – either of these can contribute to an increase in back pressure.

Extremely cold weather – if the base machine hydraulic oil is of an inappropriate viscosity grade for the ambient temperature it may well be too thick. This will cause an increase in back pressure in the drain hose.

Faulty Blow-Off Valve on the motor casing – check that this has a minimum crack pressure of 6 bar and a maximum of 7 bar. Replace if unsure using a new calibrated valve and a new sealing ring.

Leaking seals on the sequence valve cartridge leading to excessive drain line flow rate – remove the drain line from the EMV and measure leakage flow rate. Leakage in excess of 5 l/min (1.33gpm) indicates either a seal kit problem with the sequence valve or high internal motor leakage. Split the sequence valve drain line and motor case drain line and measure leakage rates independently – the sequence drain line should have little or know leakage.



## **OIL BLOWING OUT OF THE GEARBOX BREATHER VALVE & THE GEAR BOX IS FULL OF OIL**

The drive motor case seal has been blown, typically because the drain line pressure has been exceeded.

The unit will need to be removed from the job site and repaired in a suitably equipped workshop. The oil in the box will be a mixture of hydraulic and gear oils.

Once in the workshop drain the oil from the gearbox and inspect the oil for signs of debris. If only the seal has blown out without any damage to the motor casting then it may be possible to repair the motor with an authorised Parker Hydraulics (VOAC) distributor, change the gear oil and rebuild the unit.

If however, the motor casting has also been damaged in the area of the seal housing it will be necessary to completely inspect the inside of the gearbox. Remove the gearbox lid and inspect the gear teeth and inspect all bearings. Check the gears for any signs of damage. Remove all bearing covers from the gearbox sides and inspect the outer races for signs of grooves or any other contamination or damage – look at the rollers in each bearing. The bearings and all running faces should be in perfect condition, if not they will need to be replaced. Consult with the manufacturer at this stage or one of their approved distributors – it is strongly recommended that the unit be repaired by the manufacturer in order to ensure correct procedures and materials are used for an effective repair.



## **CLAMP CLOSSES ITSELF IMMEDIATELY AFTER BEING OPENED**

This fault can only occur on older units prior to serial number 45-083 without the reverse flow check valve fitted to the return motor port. It occurs when the D reg check valve on the flow regulator becomes jammed shut. When opening the clamp the drive motor can then rotate slowly. Once the control lever is released the motor effectively becomes a pump, driven by the inertia of the eccentric weights in the gearbox. Consequently the clamp can be driven closed again. Should this problem occur Dawson could supply a reverse flow check valve as a fix.

Check the condition of the Hard Jaws.



## **CLAMP LOOSES GRIP ON THE PILE**

The clamp can also loose grip on the pile when clamped, with the vibrator not vibrating, if the check valve on the rear of the clamp cylinder has faulty/leaking seals or if the clamp cylinder piston seals are damaged/worn.

Alternatively there may be insufficient system operating pressure if the sequence valve setting has been adjusted down in order to attempt running on an unsuitable excavator. Check the system operating pressure and excavator specifications.



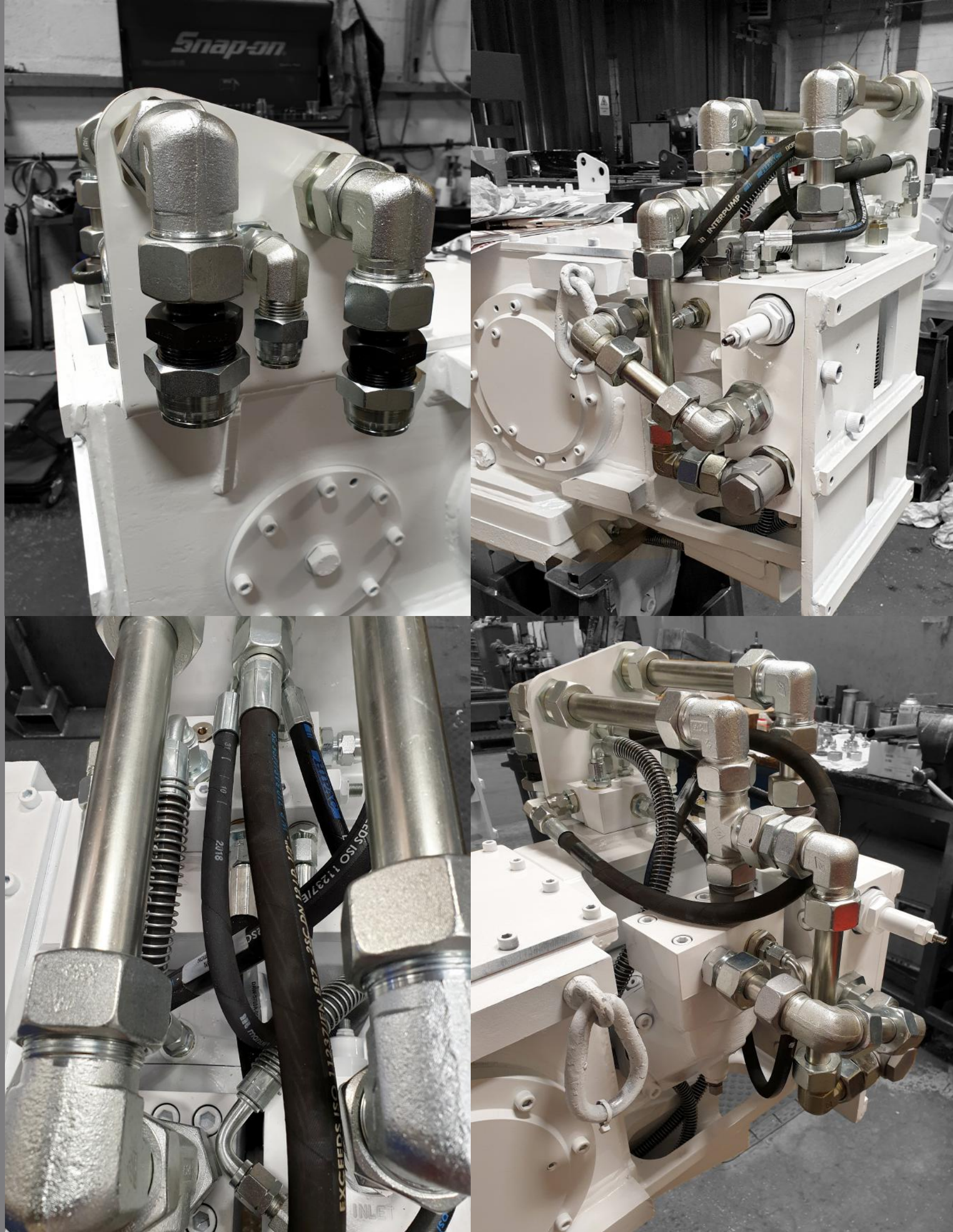

### EMV 550 Hard pipe kit Part No 5771 Fittings

- 1 3/4" BSP to 3/8" BSP reducing bush
- 2 1 1/2" BSP to 1" BSP reducing bush + dowty (not WD)
- 3 1 1/2" BSP to 1 1/4" BSP fixed female
- 4 1" BSP to 25S + WD stud coupling
- 5 1" BSP to 30S stud coupling + Dowty
- 6 30S run tee
- 7 30S to 25S reducer (REDVDN30/25S)
- 8 25S elbow
- 9 25S swivel elbow
- 1 1/4" BSP to 30S + WD stud coupling
- 30S elbow
- 30S swivel elbow
- 30S bulkhead fitting
- 25S banjo

### Tube

- 30mm dia plated steel 4mm wall thickness 600mm long
- 25mm dia plated steel 4mm wall thickness 600mm long





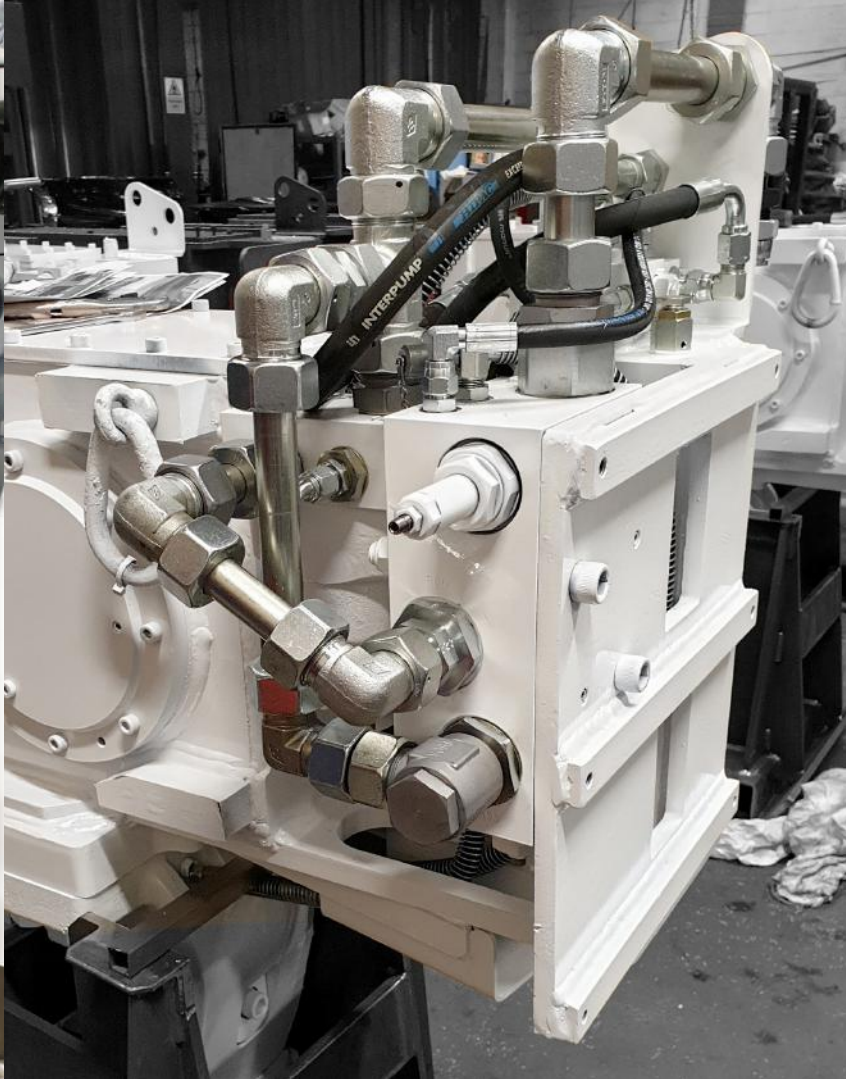

**EMV 550  
Part No 5700B**

**Fittings:**

3/8" BSP to 3/8" BSP M/M adaptor + Dowty washer (H00152)	6 off
1/4" BSP to 3/8" BSP M/M adaptor + Dowty washer	2 off
22x1.5 to 1/2" BSP M/M adaptor (H00162)	1 off
1/4" BSP to 1/4" BSP + Dowty washer (H00118)	6 off
1/2" BSP to 1/2" BSP adaptor + Dowty washer	2 off
1/2" BSP to 1/2" BSP banjo	1 off
1/2" BSP to 3/8" BSP adaptor + Dowty washer	2 off
1/2" BSP M/F compact elbow	1 off
30S end swivel T	1 off
30S centre swivel T	1 off
30S M/F swivel elbow	2 off
30S blank plug	1 off
30S M/M elbow	1 off
3/4" BSP blank cap	1 off
3/8" BSP swivel elbow + test point	1 off
1" BSP to 30S stud coupling + WD	1 off
1 1/4" BSP to 1 1/4" BSP M/M adaptor + Dowty washer	2 off
1 BSP to 1 1/4" BSP adaptor + dowty washer	1 off
1 1/2" BSP to 1 1/4" BSP fixed female adaptor	3 off
1 1/4" BSP to 30S stud coupling + WD	1 off
1 1/4" BSP blank caps	2 off
30S bulkhead fitting + nut	2 off
3/4" bulkhead fitting + nut	1 off
3/4" BSP M/F compact elbow	1 off
30mm dia 4mm wall steel tube x 800 mm	1 off

**Hoses:**

1" 4SH 1 1/4" BSP swept 90° to 1 1/4" BSP swept 90° AOR 0° 1250mm C to C + SG (ZZ00031523)	1 off
1" 4SH 1 1/4" BSP swept 90° to 1 1/4" BSP swept 90° AOR 0° 1450mm C to C + SG (ZZ00031525)	1 off
1/2" EP-08 1/2" BSP straight to 3/4" BSP straight 820mm C to C (ZZ00031517)	1 off
1/2" EP-08 1/2" BSP swept 90° to 1/2" BSP straight 400mm C to C (ZZ00031531)	1 off
3/8" EP-06 3/8" BSP swept 90° to 3/8" BSP straight 940mm C to C + SG (ZZ00031512)	1 off
3/8" EP-06 3/8" BSP swept 90° to 3/8" BSP straight 1110mm C to C + SG (ZZ00031504)	1 off
3/8" EP-06 3/8" BSP swept 90° to 3/8" BSP straight 295mm C to C (ZZ00031502)	1 off
3/8" EP-06 3/8" BSP swept 90° to 3/8" BSP straight 310mm C to C (ZZ00031503)	1 off
3/8" EP-06 3/8" BSP swept 90° to 3/8" BSP straight 650mm C to C (ZZ00031530)	1 off
1/4" EP-04 1/4" BSP swept 90° to 1/4" BSP straight 385 C to C (ZZ00031514)	1 off
1/4" EP 1/4" BSP swept 90° to 1/4" BSP swept 90° AOR 0° 400mm C to C (ZZ00031516)	1 off

EMV550 bsp





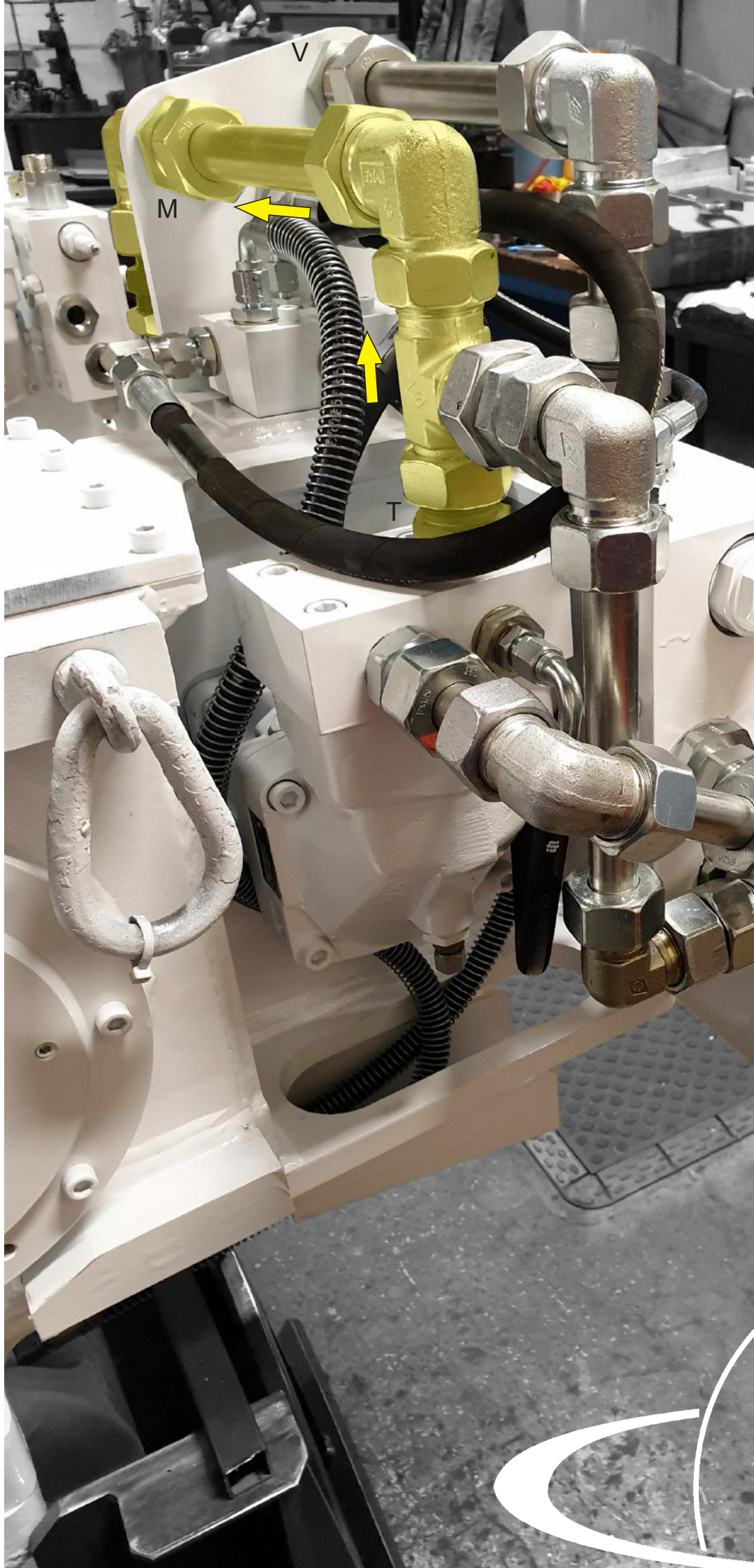
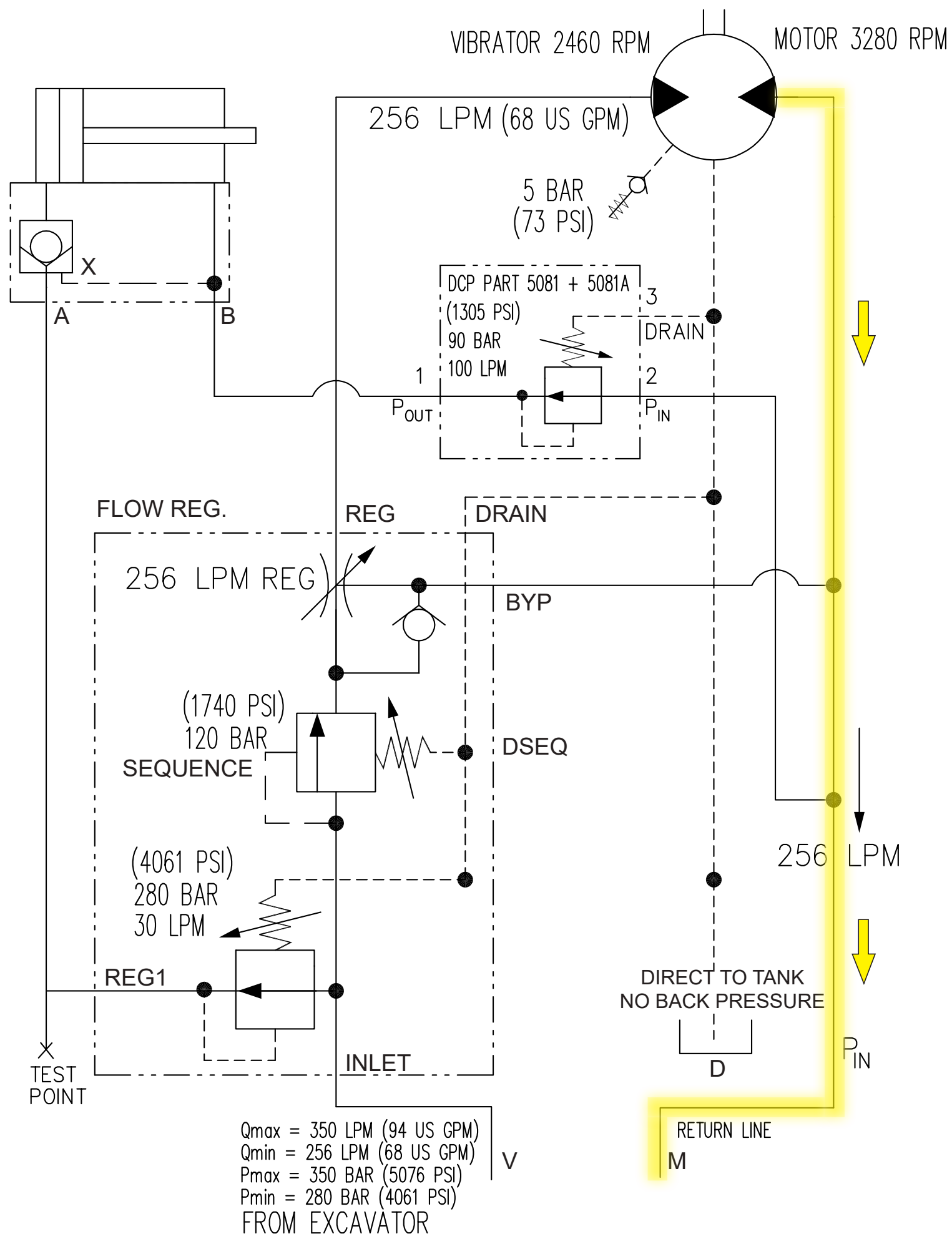

return line

emv550 bsp hydraulic circuit





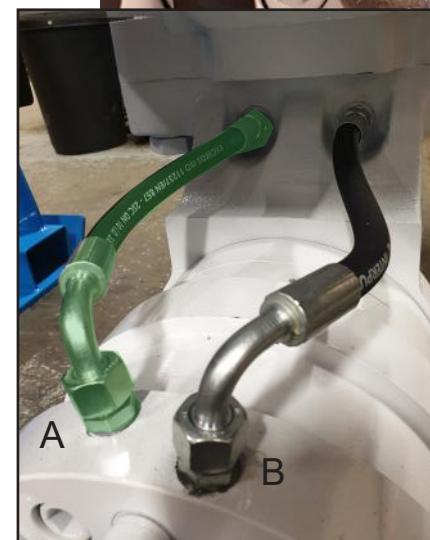
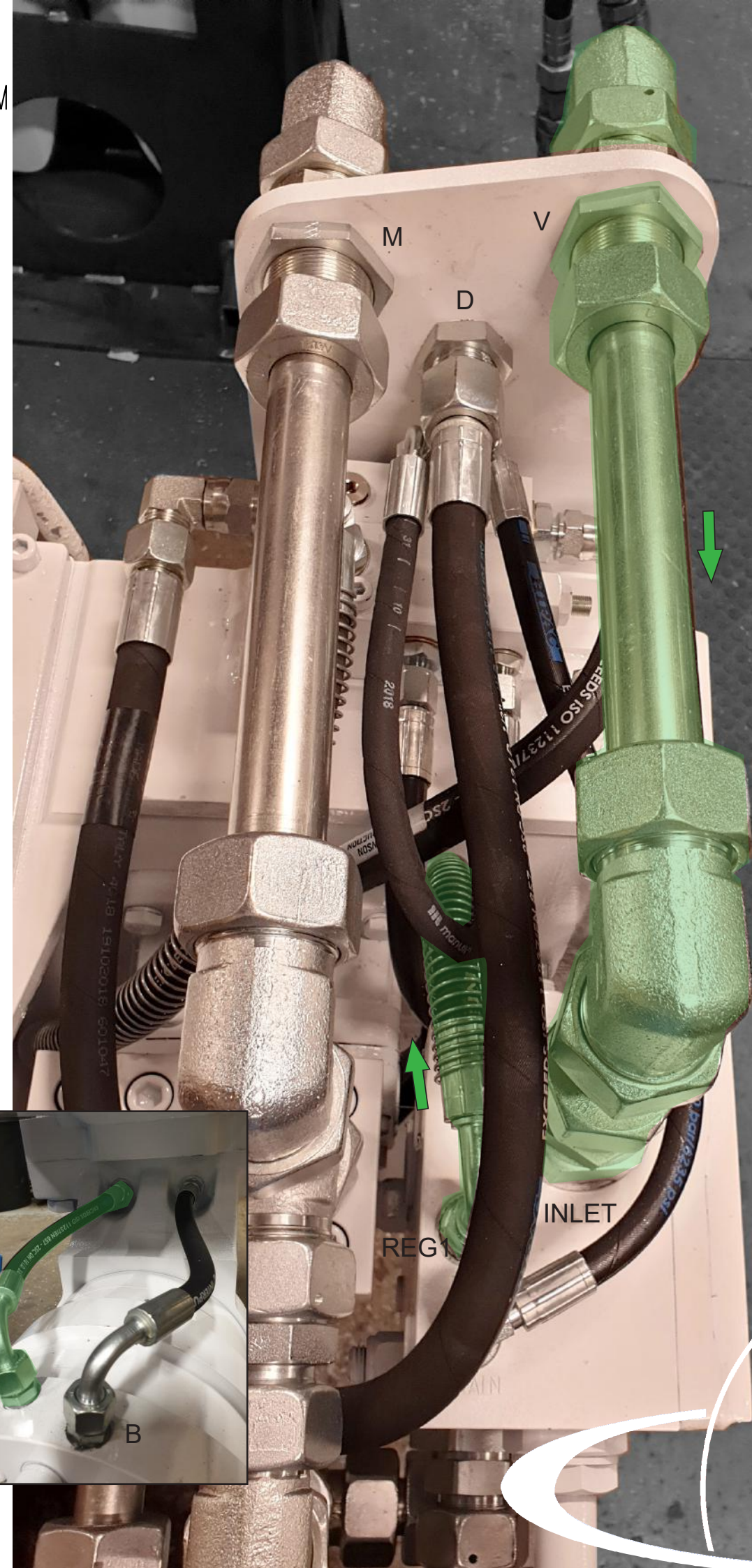
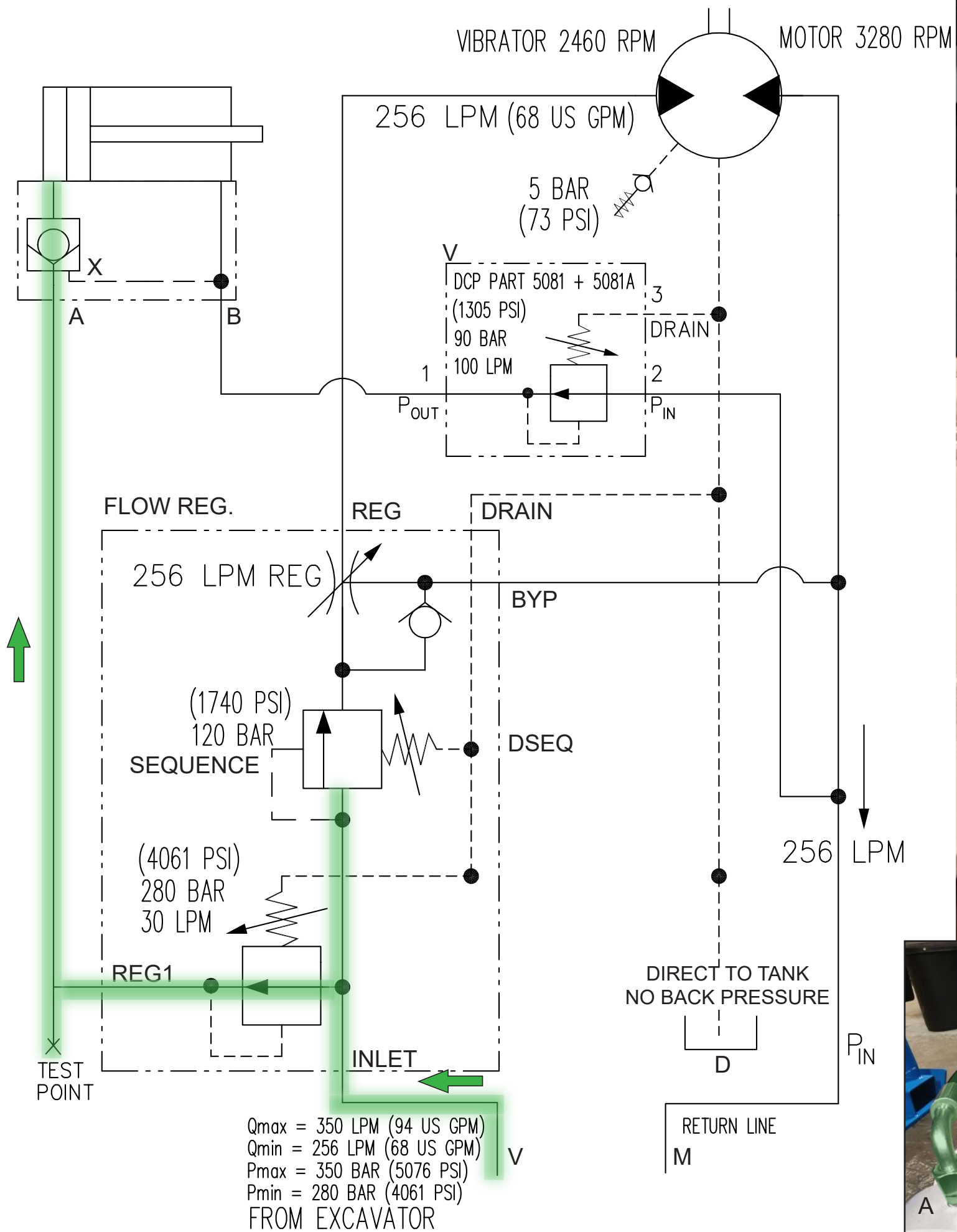

emv550 bsp hydraulic circuit

clamp engaged





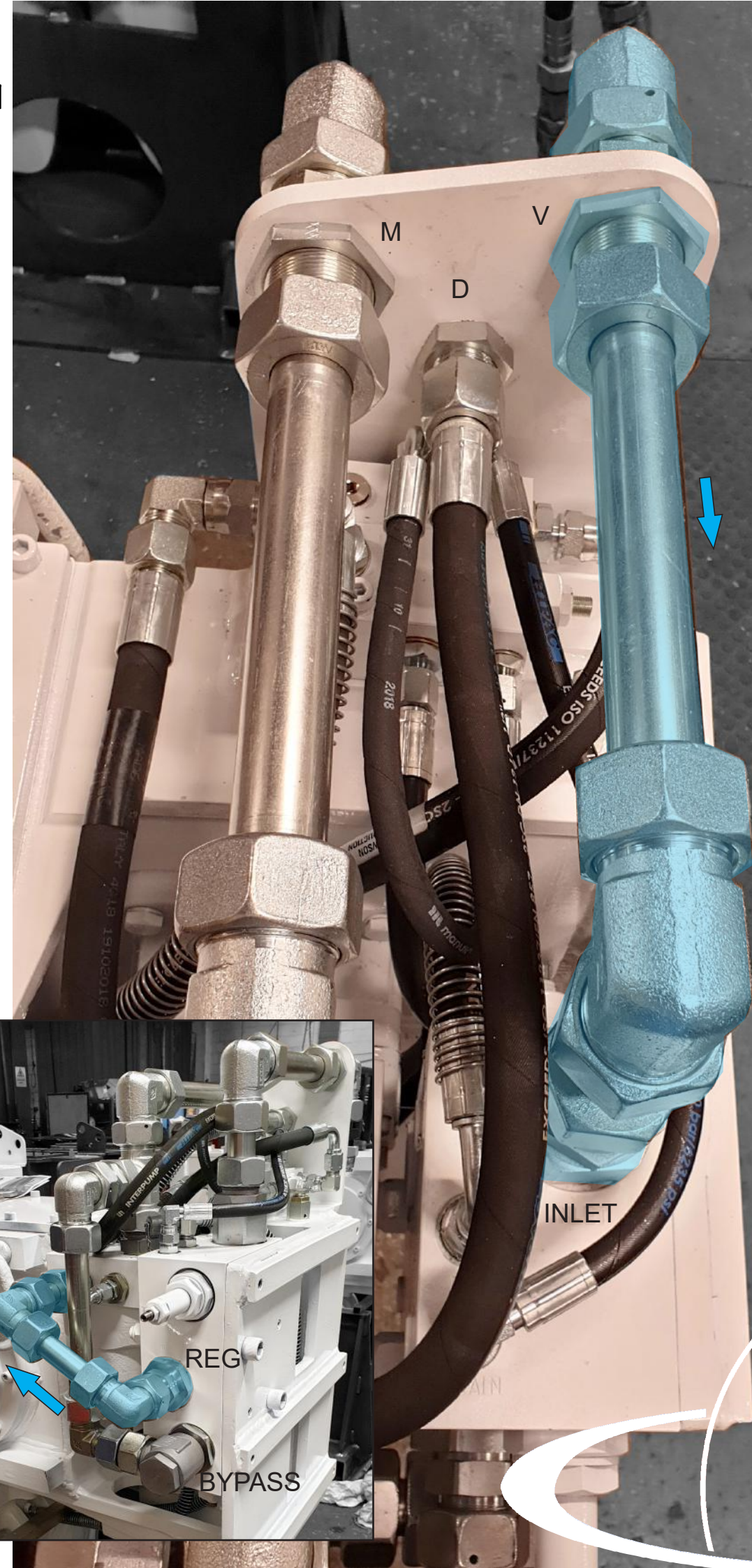
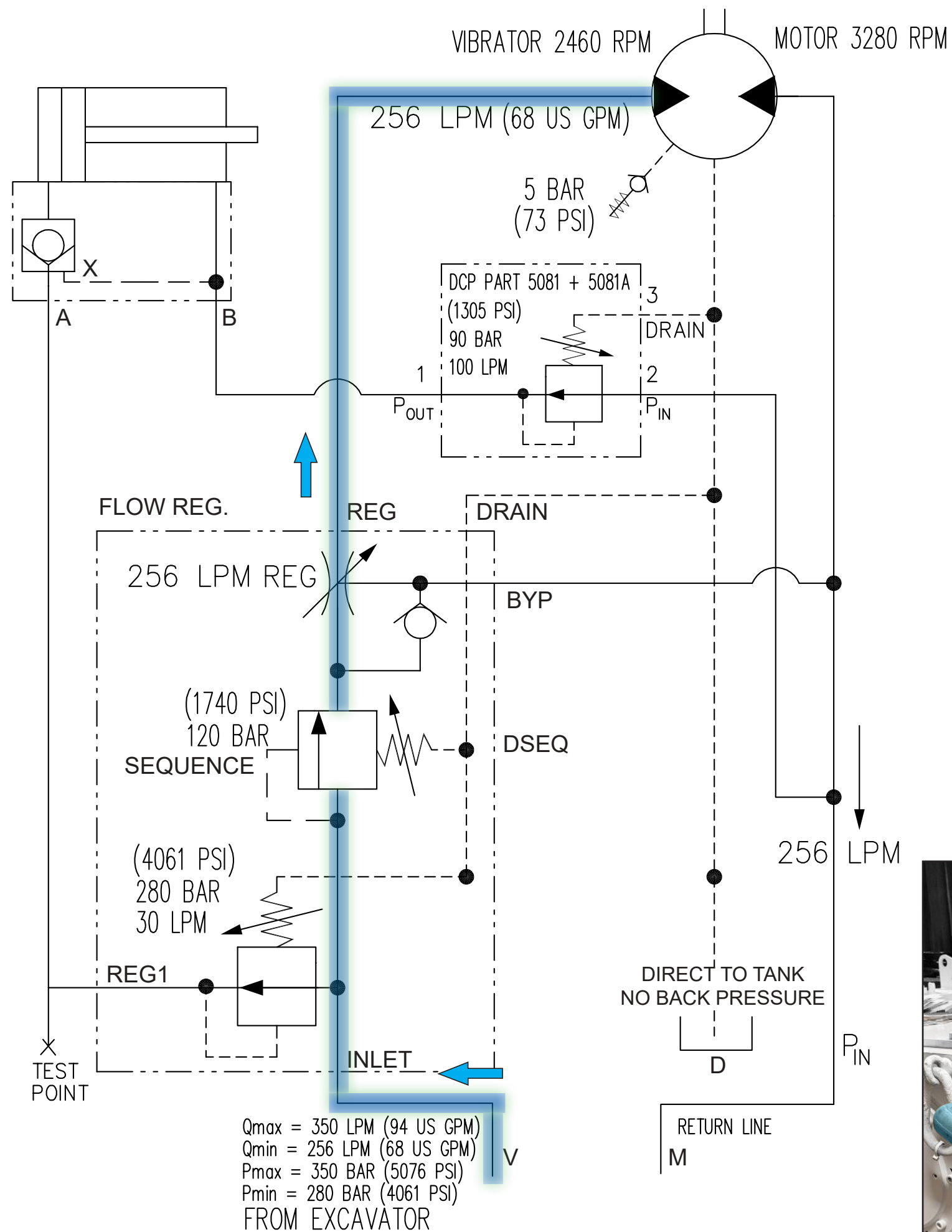

emv550 bsp  
hydraulic circuit

drive motor supply





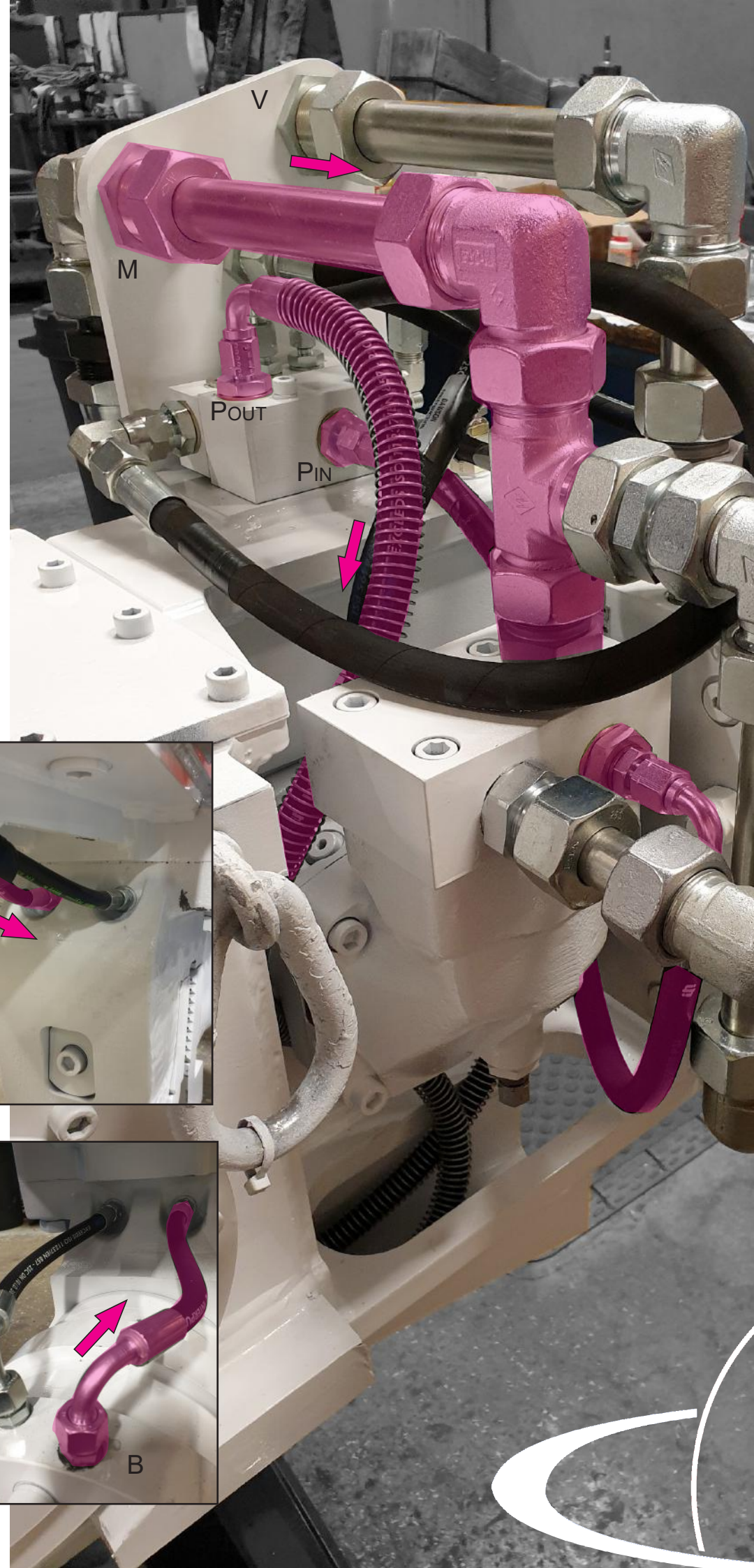
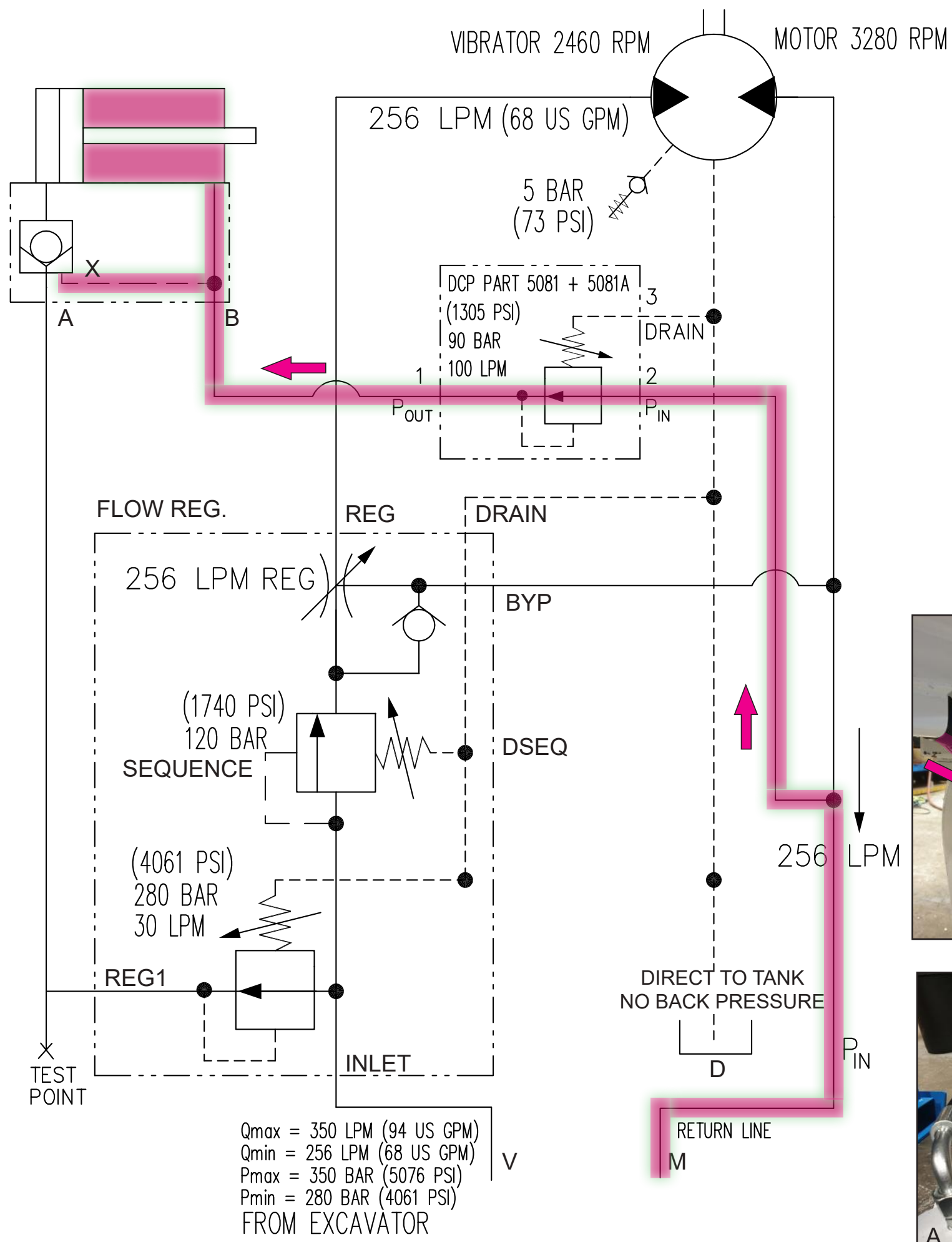

clamp disengaged

emv550 bsp hydraulic circuit





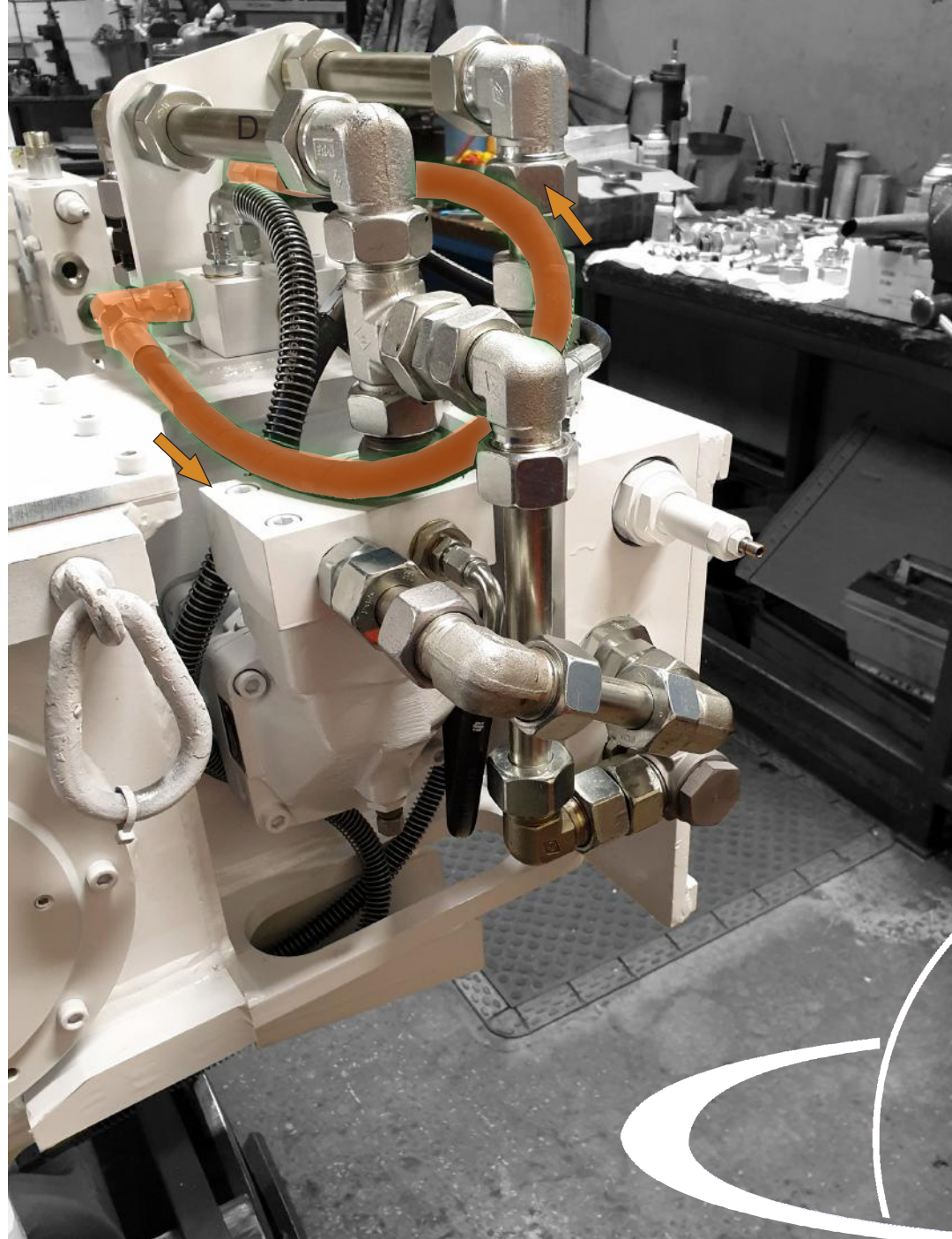
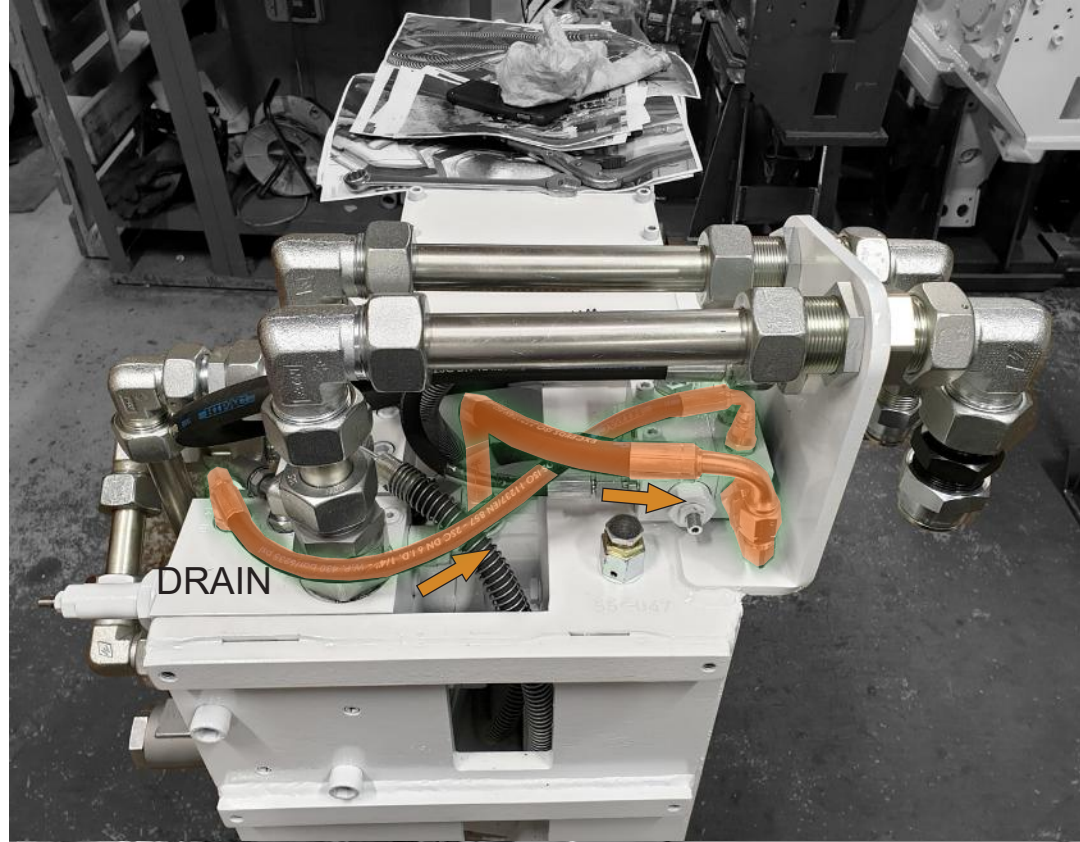
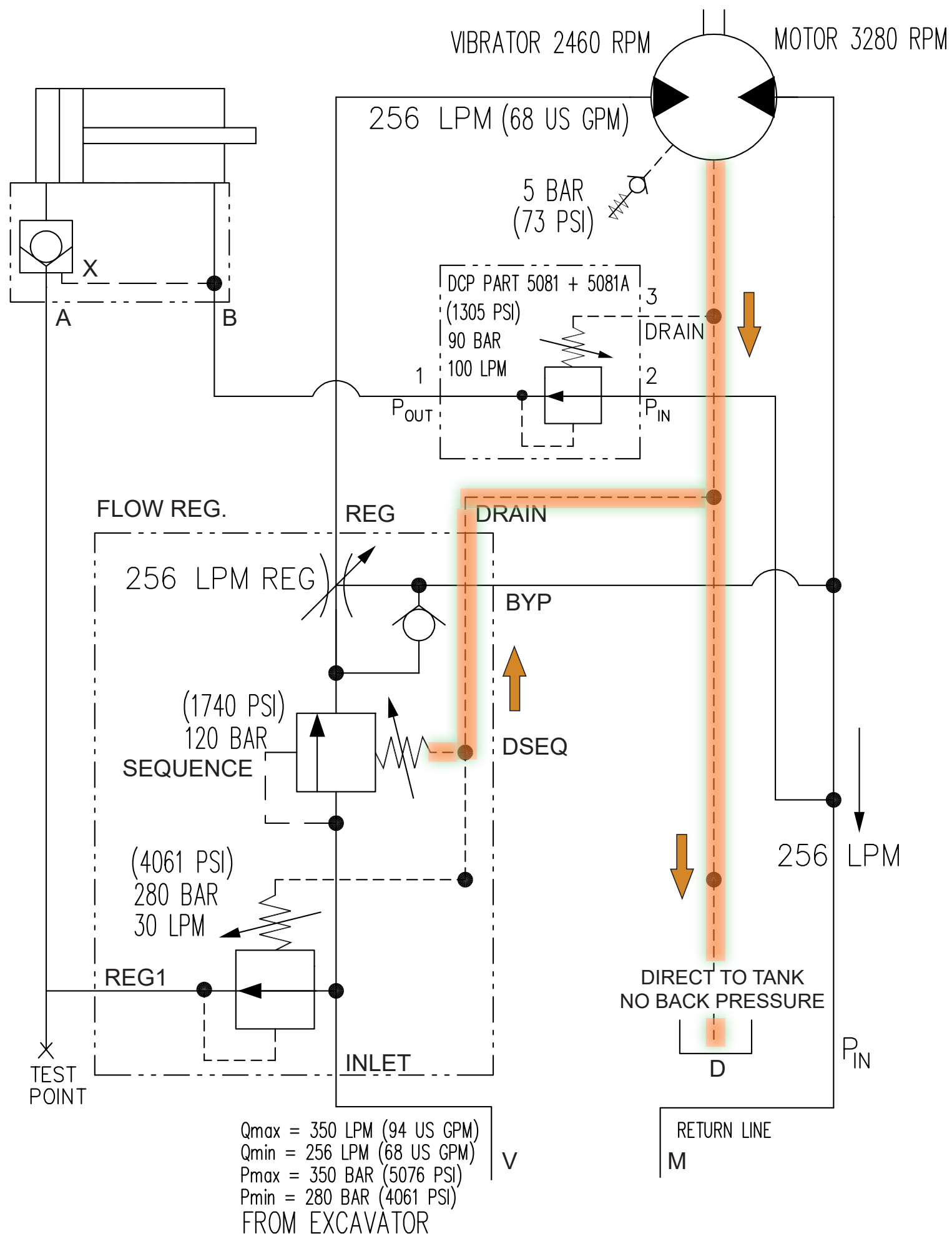

drain

emv550 bsp hydraulic circuit



# parts lists for the emv550

---

---

---

---

---



Rev/Cont	Revision	Date	Intro	Apprv
A	Drive gear now has 40 spline and adaptor no longer required	18-02-13		FLW
B	M10 CAPHEADS ADDED	30/01/14		MOB
C	M10x35 CAPHEADS ADDED TO LID	26/02/14		MOB
D	ADDED 5080 / 5081	01/02/21		MOB

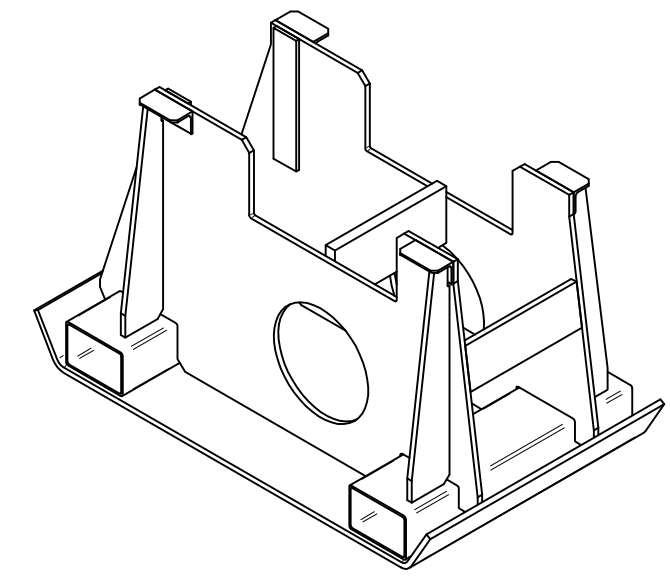

EMV550 Stand	EN43A	5671
--------------	-------	------

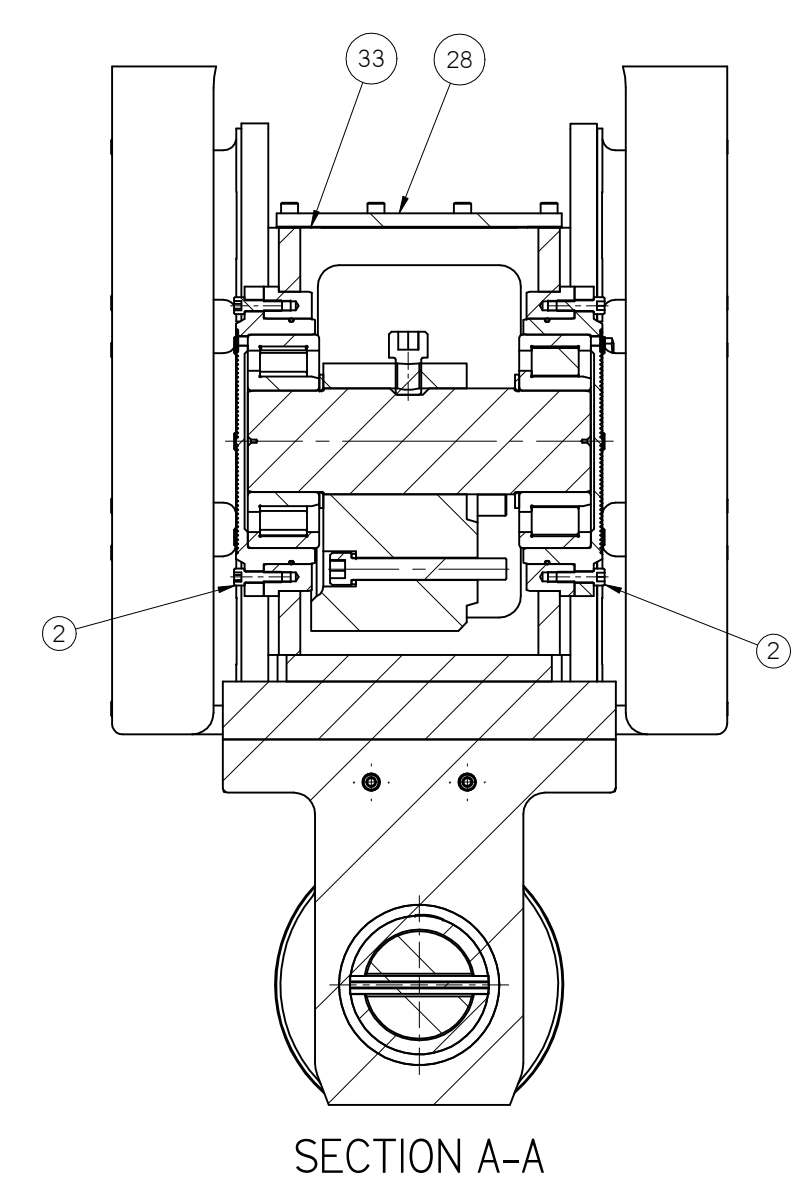
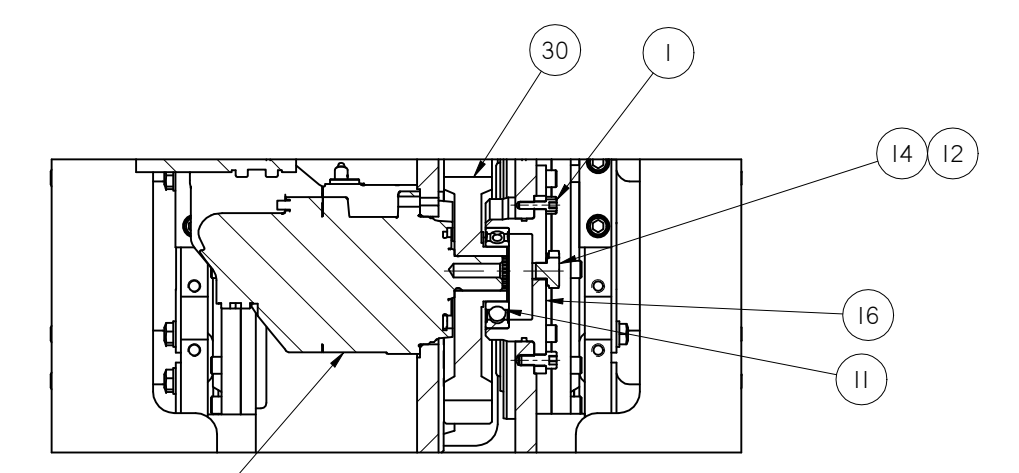
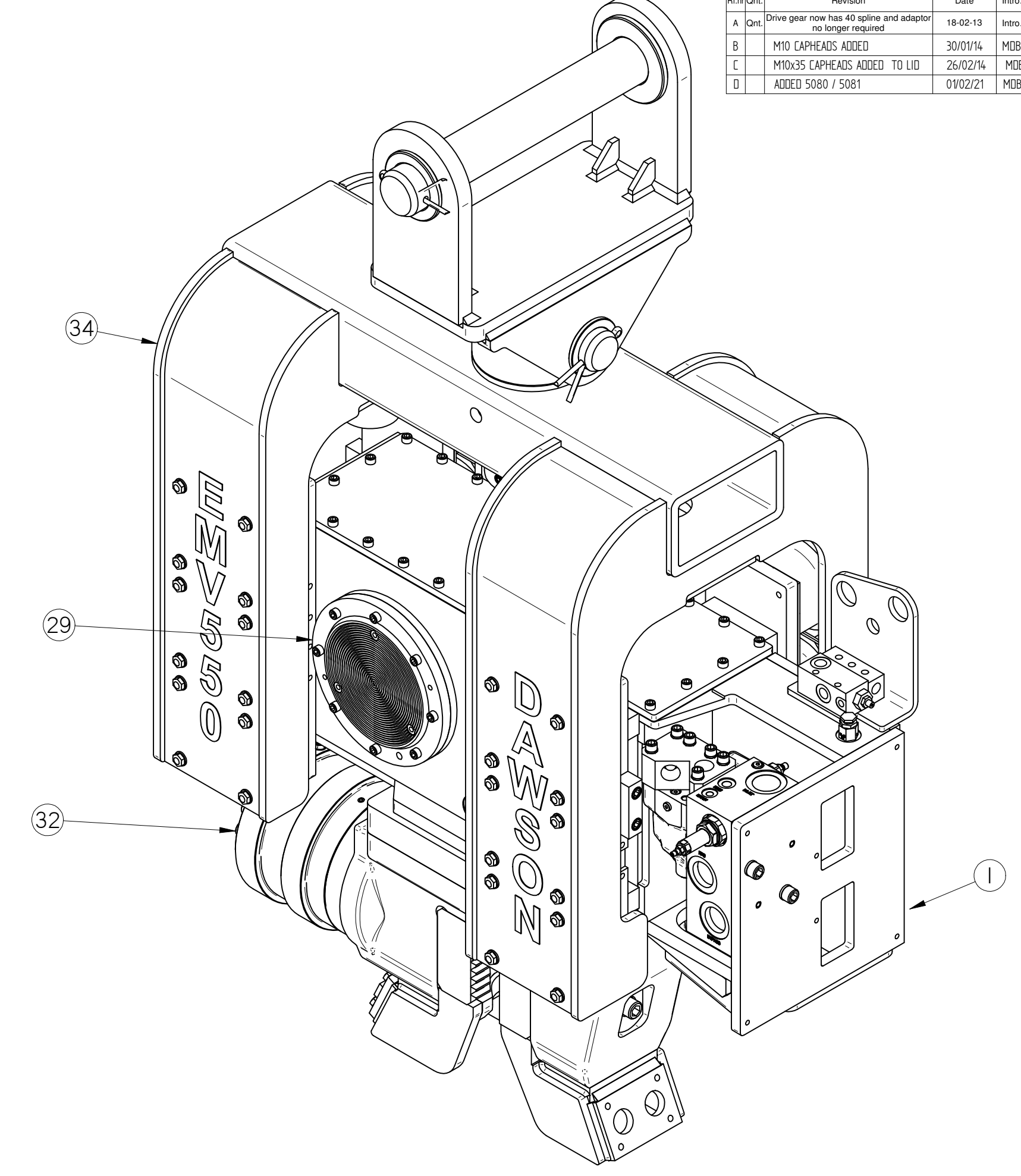
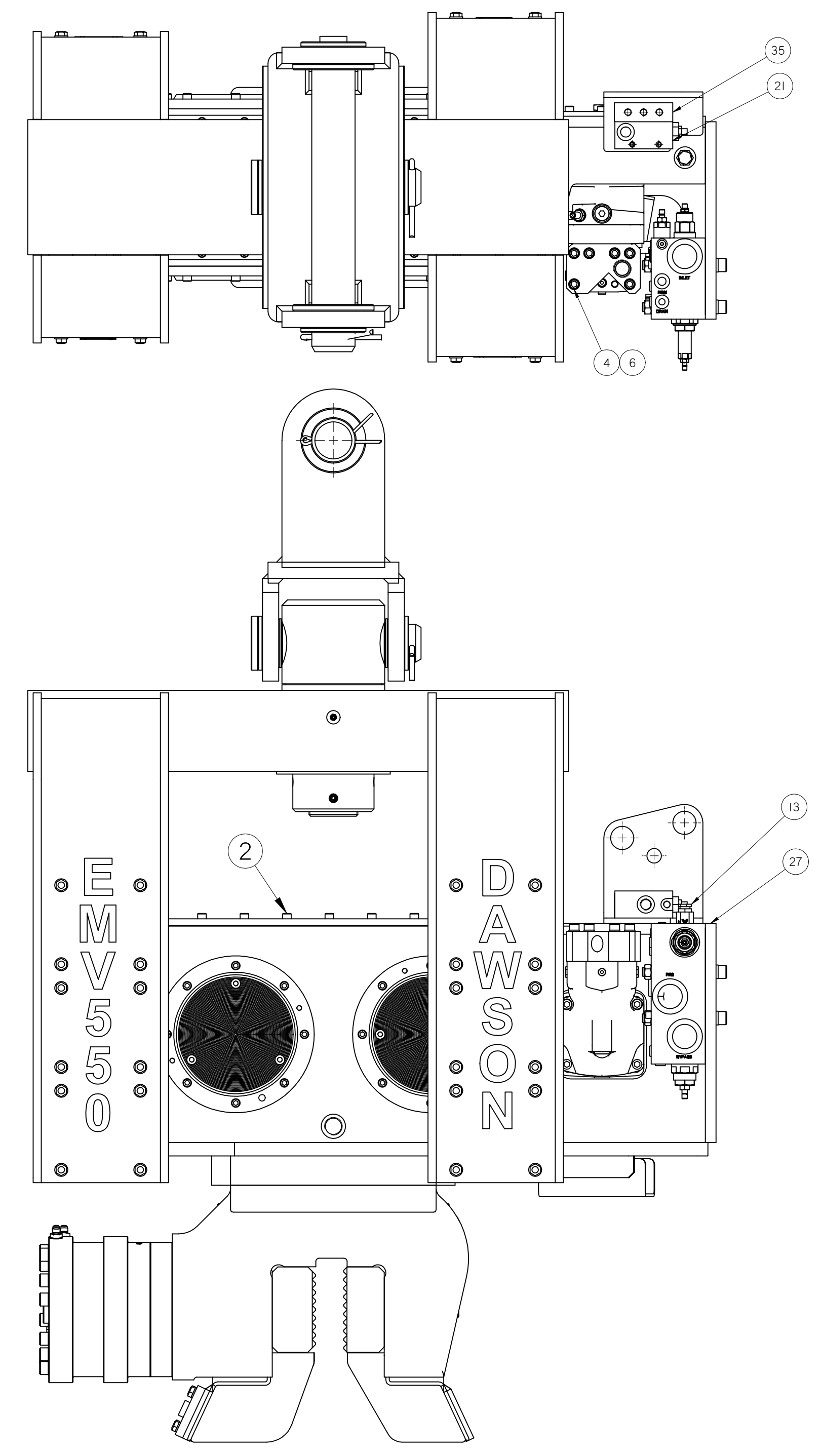
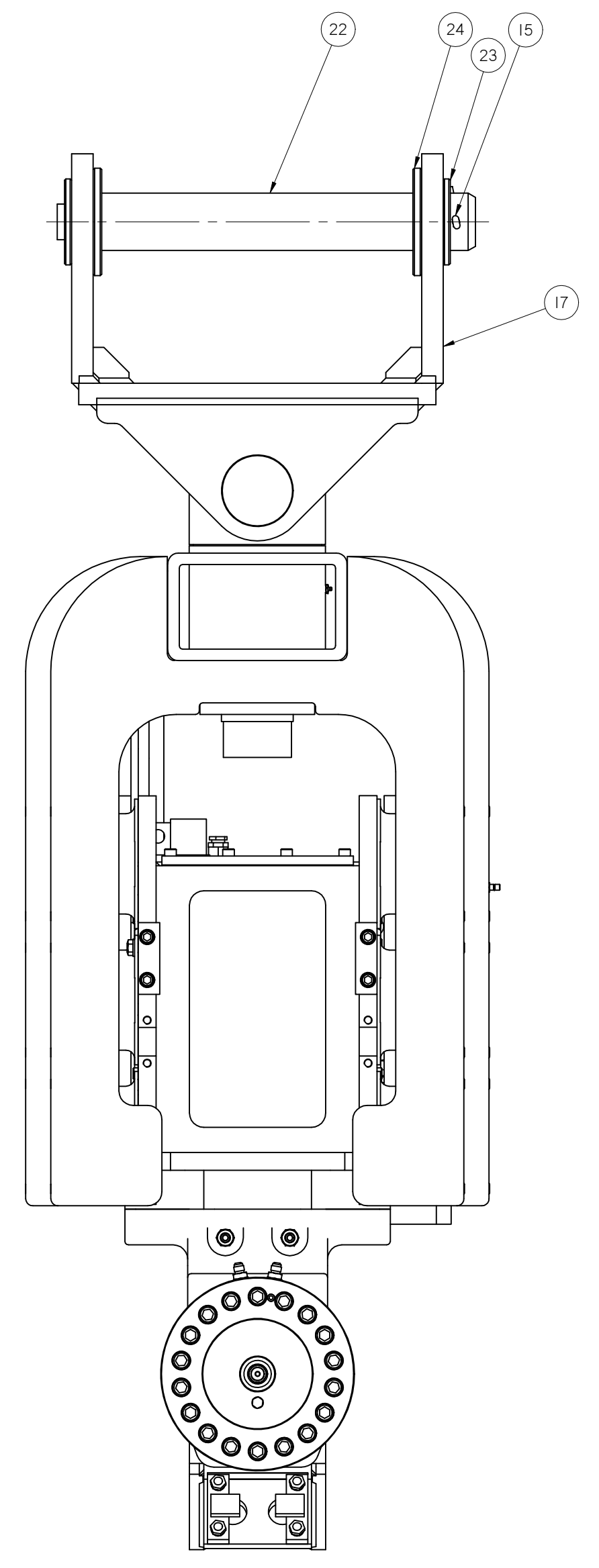
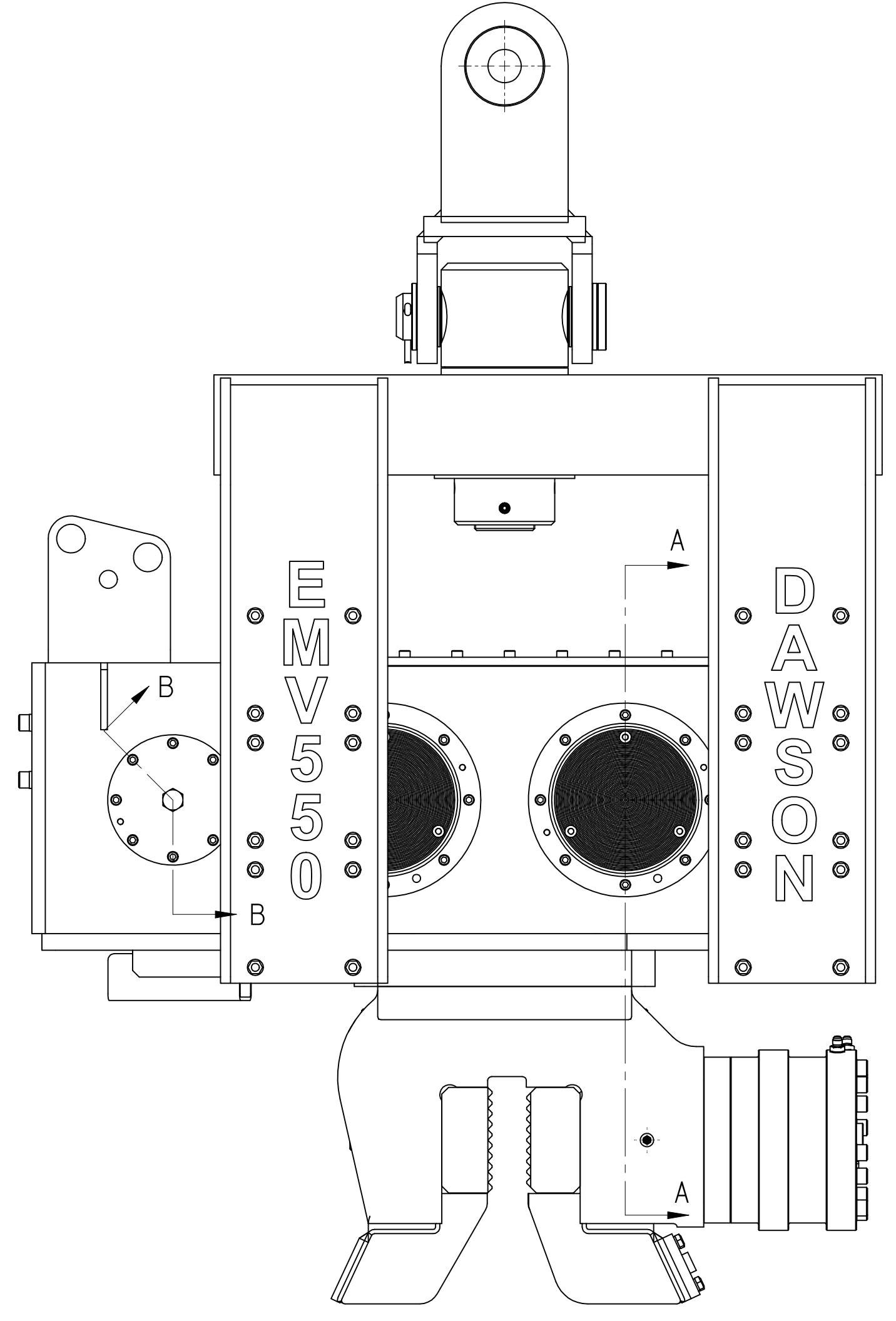

TOTAL WEIGHT = 1550Kg APPROX.  
 CLAMP FORCE = 66 Tonne  
 CENTRIFUGAL FORCE = 564kN  
 REQUIRED HYDRAULIC FLOW RATE = 256L/Min  
 MIN. OIL PRESSURE = 280 Bar

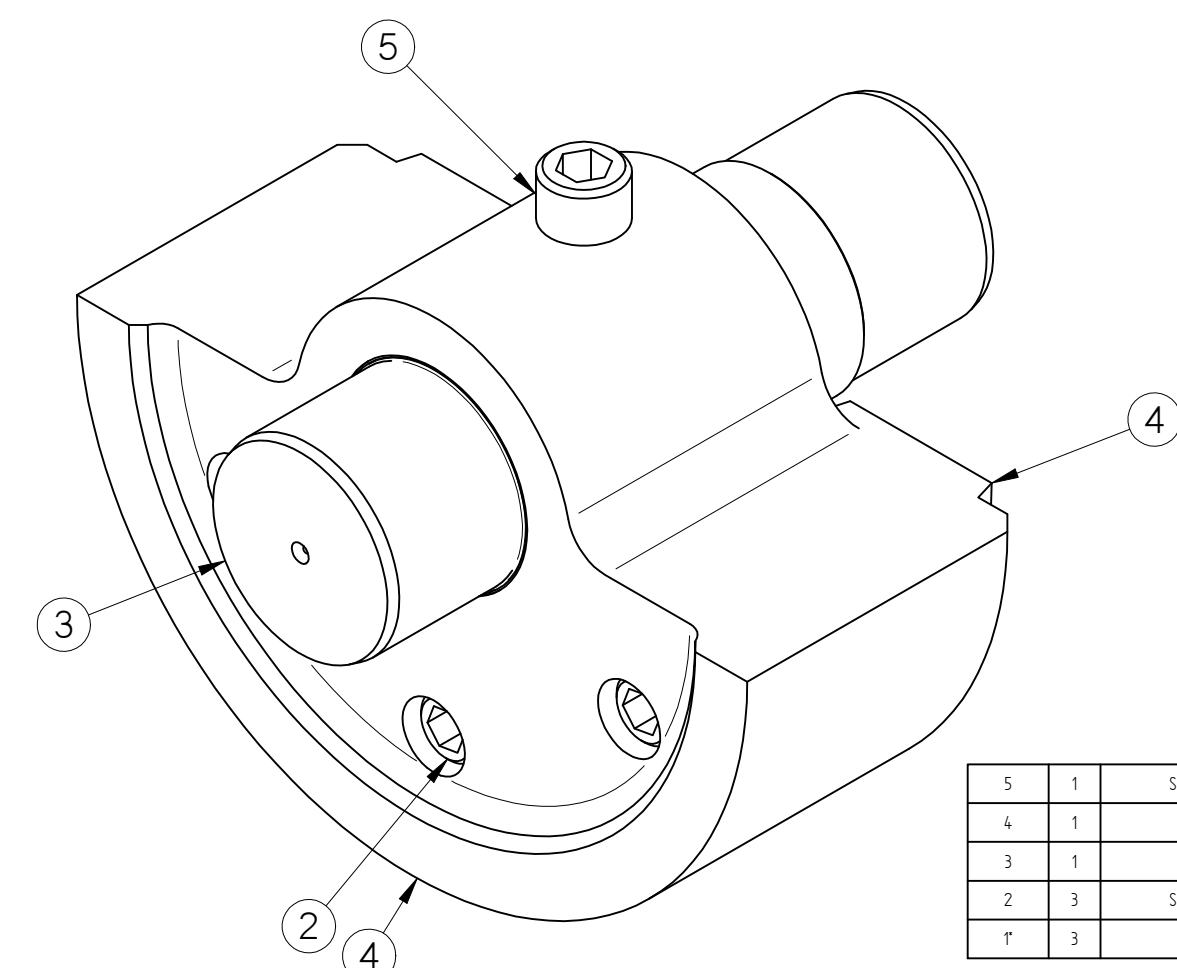
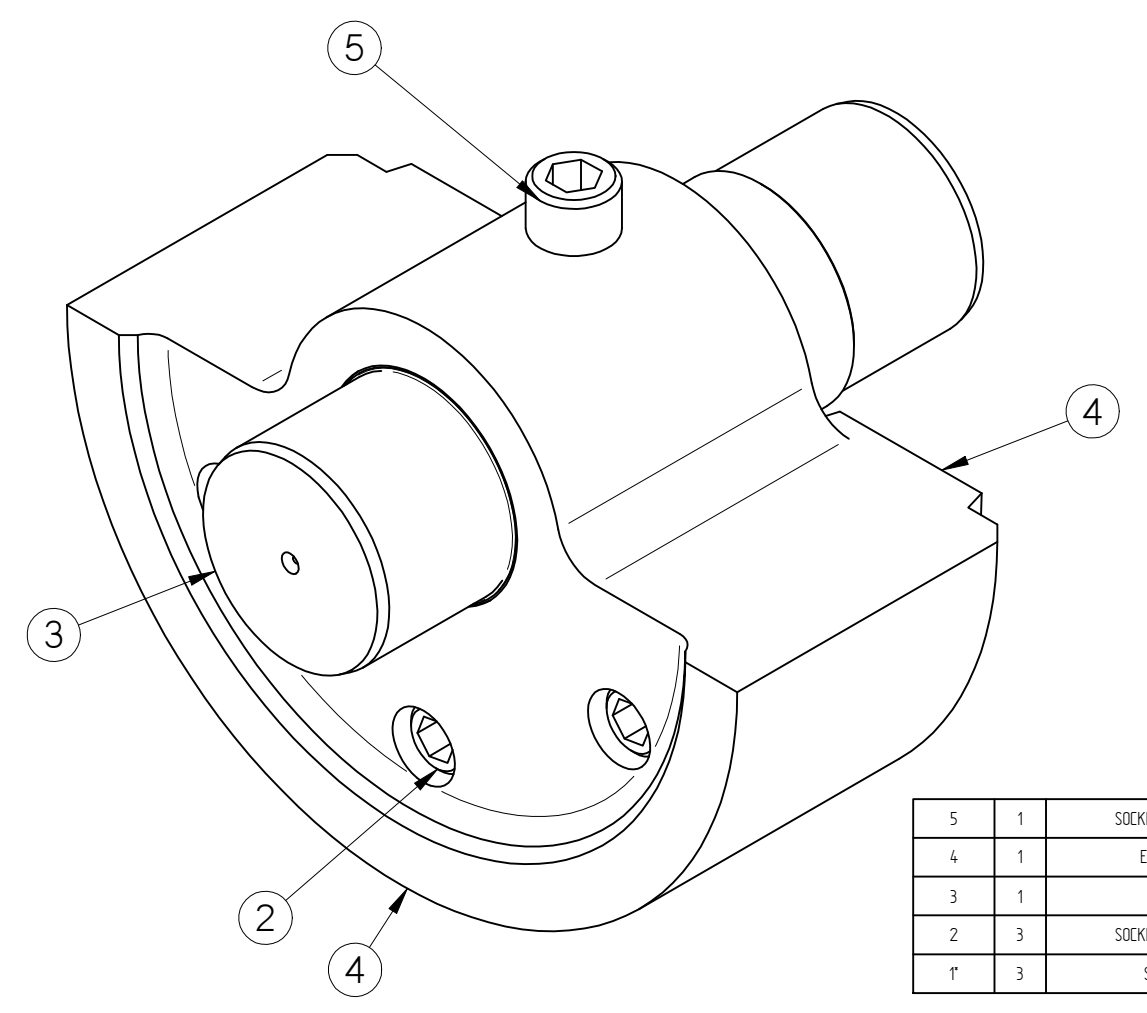

Part No.	Qty	Description	Material	Dimension	Remark
5	1	SOCKET HEAD CAP SCREW	DP24-35-02	DP24-35-02	
4	1	Eccentric Weight	BS 4360 EN508	5608-550	
3	1	Main Shaft	En 24	5607	
2	3	SOCKET HEAD CAP SCREW	M20 x 145	DP20-145-02	
1	3	SPRING WASHER	M20	DP20.000.21	

Part No.	Qty	Description	Material	Dimension	Remark
5	1	SOCKET HEAD CAP SCREW	DP24-35-02	DP24-35-02	
4	1	Eccentric weight	BS 4360 EN508	5608-550	
3	1	Main Shaft	En 24	5607	
2	3	SOCKET HEAD CAP SCREW	M20 x 145	DP20-145-02	
1	3	SPRING WASHER	M20	DP20.000.21	

Part No.	Qty	Part Name	Material	Dimension	Remark
407	1	O-RING	O Ring Ø19.37 x Ø26.2mm Nitrile	BS161 Stanton ref ORAD00161	P2410-15-01
PP	2	O-RING			H00345
38	1	HYDRAULIC MOTOR P12-80			56751
37	4	CYLINDRICAL ROLLER BEARING	N2279-4-TYP2-4 J2319E		5632
36	4	O-RING	Ø22.84 x Ø35.3	Dowly 200-269	5630
35	1	MANIFOLD BLOCK			5621
34	1	Saddle Assembly			5620
33	1	EMV 550 GASKET		NAB6 1mm Thick	5619
32	1	Clamp Assembly			5618
31	4	Thrust Washer			5611
30	1	Drive Gear			5610
29	4	Main Shaft End Cap	BS 4360 EN508		5605
28	1	Cover Plate	BS 4360 EN508		5604
27	1	Modified Case Welded Assembly			5603 P12-80
26	1	DRIVE GEAR B ASSEMBLY			5598
25	1	DRIVE GEAR A ASSEMBLY			559A
24	2	Installation Bush 150 X 80 X 12g			5505
23	1	DIPPER PIN WAGHER			5090
22	1	DIPPER PIN			5089E
21	1	SECONDARY VALVE CARTRIDGE			5081A
20	1	SECONDARY VALVE BLOCK			5081
19	1	FLOW REG & SEQUENCE VALVE			5080-1
18	1	Manifold Block	EN508		5071 P12-80
17	1	EMV 550 ADAPTOR BRACKET			5068E
16	1	Drive Shaft End Cap	BS 4360 EN508		4606
15	1	SPLIT PIN			4067
14	1	Hex Hi Bolt	M20 x 20		4061
13	1	BREATHER PLUG	SPV 10K		4043
12	1	Dowly Washer	M20		4038
11	1	BEARING	6320-2RS1		4035
10	1	BLANKING PLUG			1-098-07-01
9	2	SOCKET HEAD CAP SCREW			DP16-140-02
8	2	NORD-LOCK WASHER	M16		DP16.000.27
7	3	WALC NUT - TYPE 1	M16		DP16.000.02
6	6	SOCKET HEAD CAP SCREW	M12		DP12.065-02
5	8	SOCKET HEAD CAP SCREW	M12 x 45		DP12.045-02
4	6	NORD-LOCK WASHER	M12		DP12.000.27
3	2	Spring Pin	Ø12 x 150		DP12-150-22
2	58	SOCKET HEAD CAP SCREW	M10 x 35 LS		DP10-035-02
1	8	SOCKET HEAD CAP SCREW	M10 x 25 LS		DP10-025-02

**SURFACE FINISH**  
 UNLESS STATED OTHERWISE  
 ▽ ROUGH MACHINE N6  
 ▽ FINE MACHINE N8  
 ▽ GRIND N6

**MACHINING TOLERANCES**  
 UNLESS STATED OTHERWISE  
 F = ±0.05  
 X, XX = ±0.25  
 X, XX = ±0.05  
 ANGLES ±0.5°  
 DIMENSIONS IN MILLIMETERS

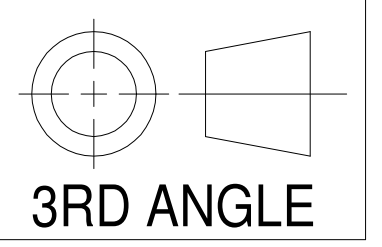

Rf.nr	Qnt.	Revision	Date	Intro.	Appr.by
A		M10 CAPHEADS ADDED	30/01/14	MDB	

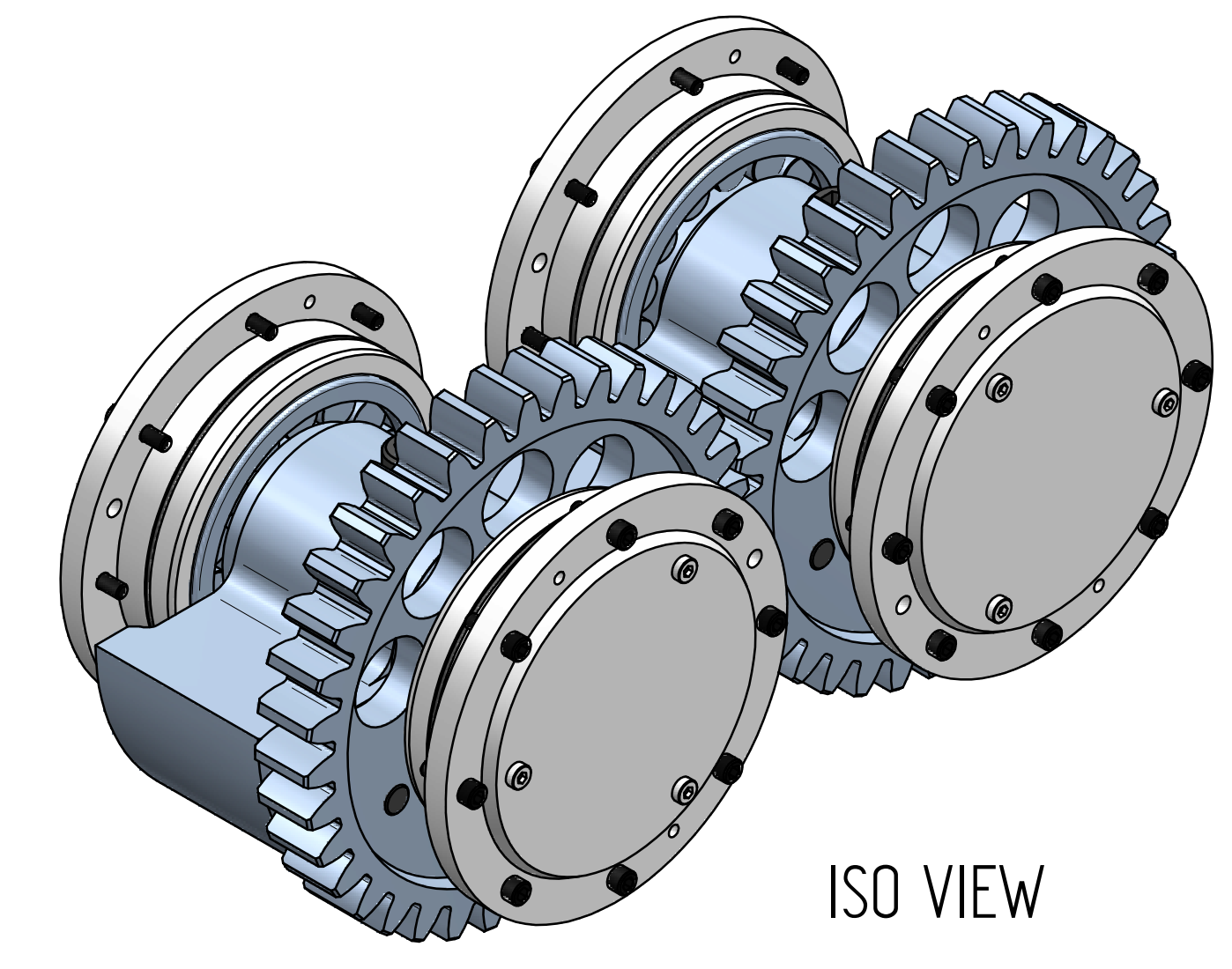

ISO VIEW

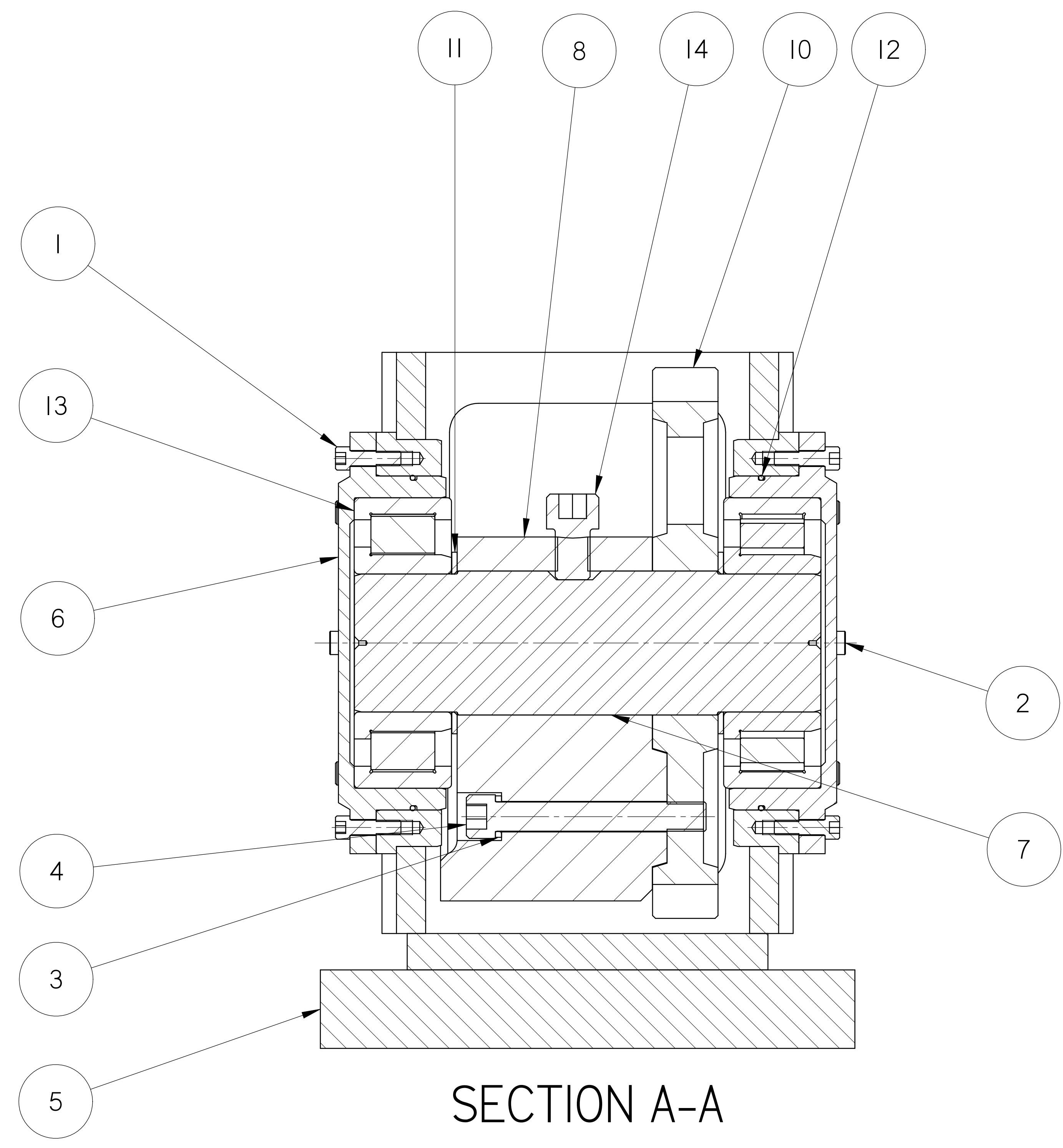

SECTION A-A

14	2	SOCKET HEAD CAP SCREW		OM24-35-02	OM24-35-02
13	4	CYLINDRICAL ROLLER BEARING	NJ2319-E-TY P2+HJ2319E		5632
12	4	O-RING	Ø221.84 x Ø3.53	Dowty 200-269	5630
11	4	Thrust Washer			5611
10	1	Driven Gear B			5609B-550
9*	1	Driven Gear A			5609A-550
8	2	Eccentric Weight	BS 4360 En50B		5608-550
7	2	Main Shaft	En 24		5607
6	4	Main Shaft End Cap	BS 4360 En50B		5605
5	1	Case Welded Assembly			5603
4	6	SOCKET HEAD CAP SCREW		M20 x 145	OM20.145.02
3	6	SPRING WASHER		M20	OM20.000.21
2	12	LOW HD SHCS	M10 x 10	M10 x 10	OM10.010.09
1	32	SOCKET HEAD CAP SCREW	12.9	M10 x 35 LG	OM10-035-02

Ref.no.	Qnt.	Part name	Material	Dimension	Remark
Design by MDB	Drawn by MDB	Copied -	Checked -	Standard A3	Affirmed -
DAWSON CONSTRUCTION PLANT LTD.			<b>EMV550</b> DRIVEN GEAR ASSEMBLY		Replace - Replaced by - Date 22/02/2011 Drawing no. 5501

<b>SURFACE FINISH</b> UNLESS STATED OTHERWISE	<b>MACHINING TOLERANCES</b> UNLESS STATED OTHERWISE
▽ ROUGH MACHINE N9	X = +/- 0.5
▽▽ FINE MACHINE N8	X.X = +/- 0.25
▽▽▽ GRIND N6	X.XX = +/- 0.05
	ANGLES +/- 0.5°
	DIMENSIONS IN MILLIMETERS



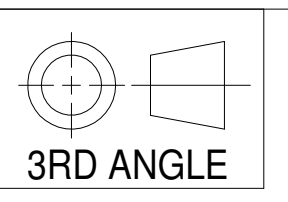

Rev.n	Qnt.	Revision	Date	Intro.	Appr.
A		O-RING CHANGE 5631 ADDED	11/02/22	MDB	

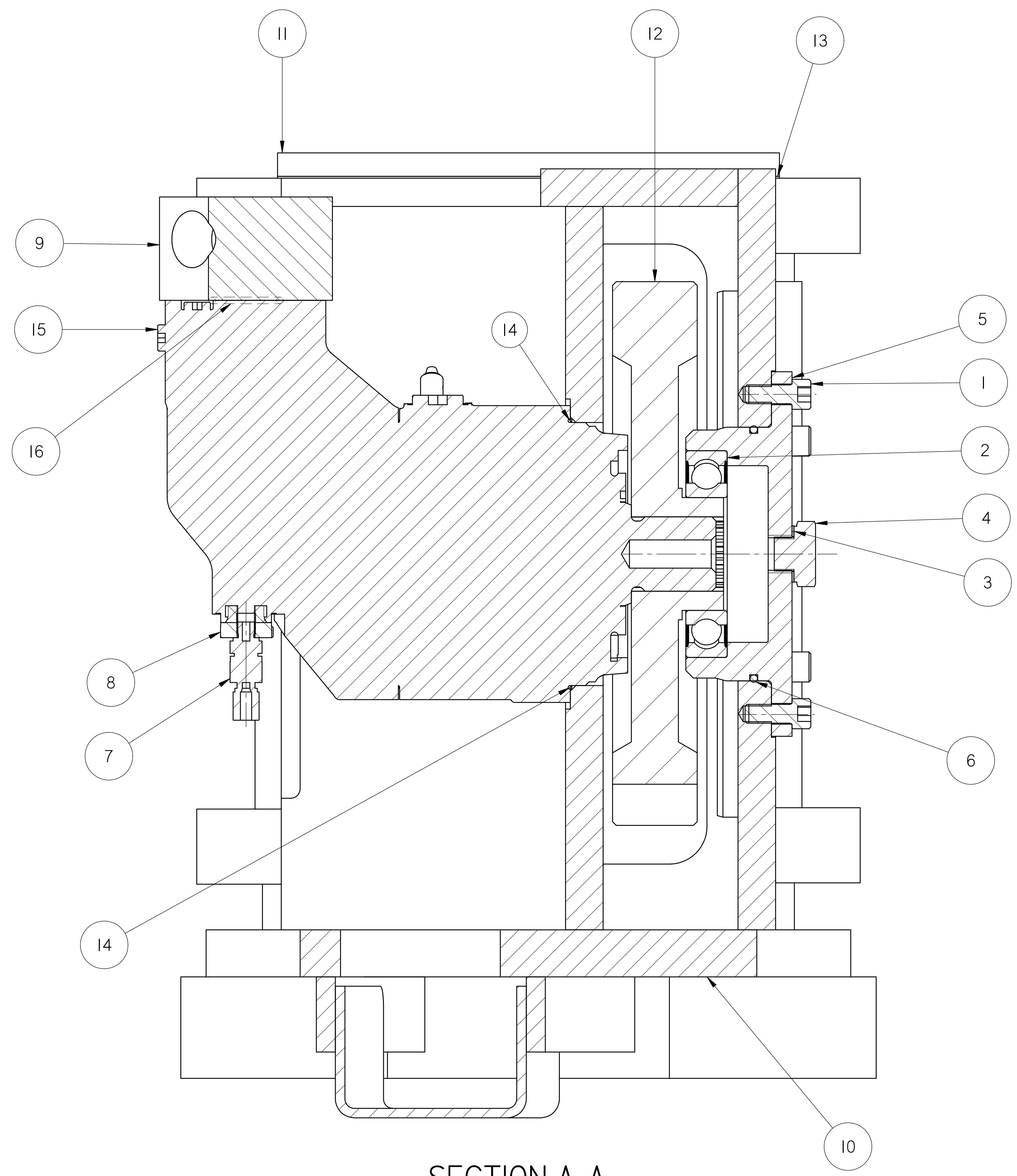

SECTION A-A

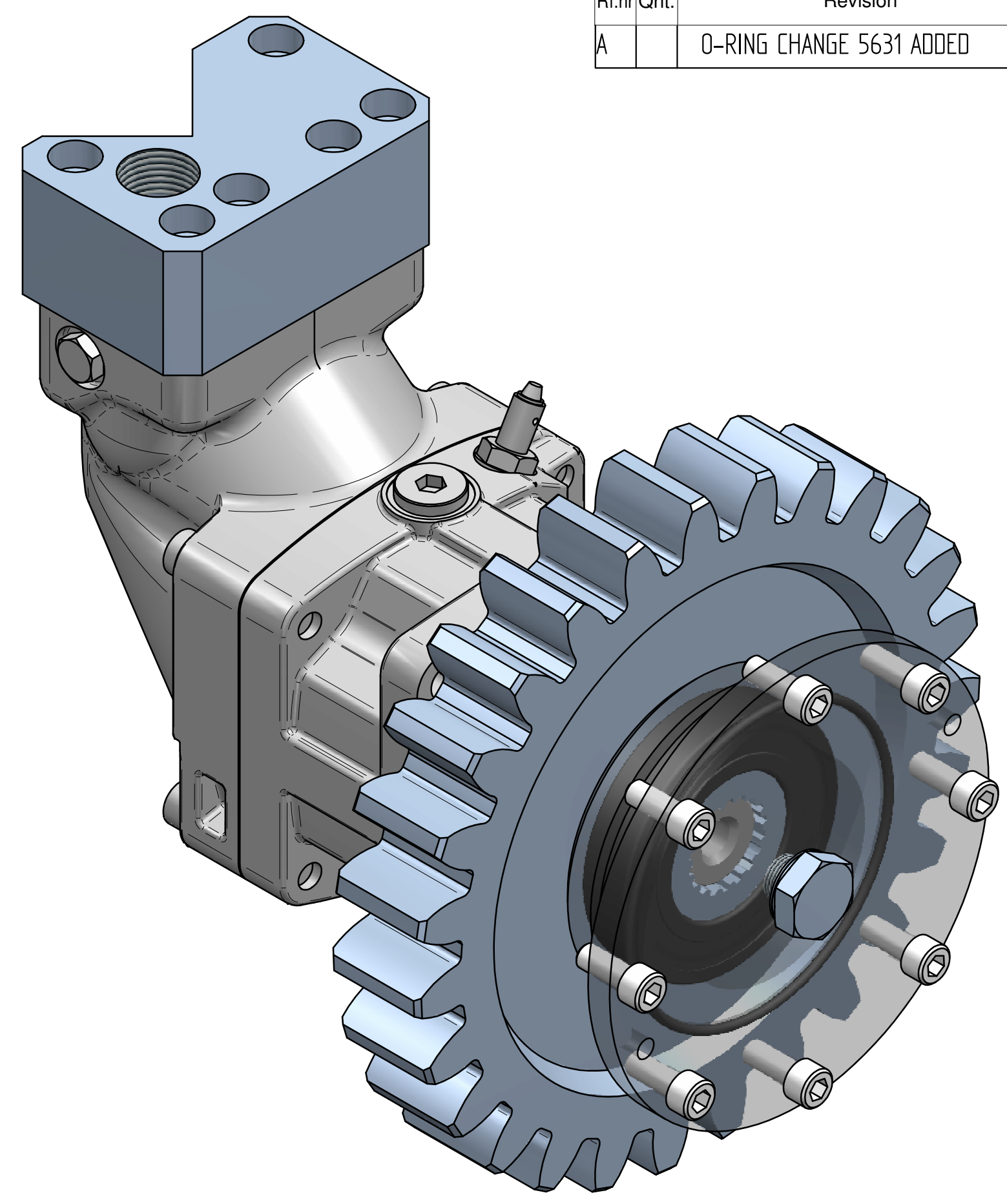

Ref.no.	Qnt.	Part name	Material	Dimension	Remark
16	2	O-RING		0.0 kg	H00345
15	1	HYDRAULIC MOTOR F12-80		36.0 kg	5675.1
14	1	O-RING	Ø140 I.D x 2mm	0.0 kg	5631
13	1	EMV 550 GASKET		0.5 kg	5619
12	1	Drive Gear		14.8 kg	5610
11	1	Cover Plate	BS 4360 En50B	21.3 kg	5604
10	1	Modified Case Welded Assembly		298.5 kg	5603 F12-80
9	1	Manifold Block	EN50B	3.6 kg	5071 F12-80
8	1	ADAPTOR		0.0 kg	4730.1
7	1	5 BAR PRESSURE RELIEVE VALVE	BSP 1/8"	0.0 kg	4695
6	1	O-RING	204-226-44 70	0.0 kg	4677
5	1	Drive Shaft End Cap	BS 4360 En50B	4.6 kg	4606
4	1	Hex Hd Bolt		0.1 kg	4061
3	1	Dowty Washer		0.0 kg	4038
2	1	BEARING	6212-2RS1	0.8 kg	4035
1	8	SOCKET HEAD CAP SCREW	12.9	0.2 kg	0M10-025-02

<b>SURFACE FINISH</b> UNLESS STATED OTHERWISE	<b>MACHINING TOLERANCES</b> UNLESS STATED OTHERWISE
▽ ROUGH MACHINE N9	X = +/- 0.5
▽▽ FINE MACHINE N8	X . X = +/- 0.25
▽▽▽ GRIND N6	X . XX = +/- 0.05
	ANGLES +/- 0.5°
	DIMENSIONS IN MILLIMETERS

Design by PLW	Drawn by MDB	Copied -	Checked -	Standard A2	Affirmed -	Scale -	Replace -	Replaced by -
				<b>EMV550</b> DRIVE GEAR ASSEMBLY		Sheet 1 of 1 Date 17/11/2014 Drawing no. 5040EMV-1		

Rev. nr	Qnt.	Revision	Date	Intro.	Appr. by
B		M5 CAP SCREW REPLACED WITH 1/8" BSP BLANKING PLUG	02/10/20	MJB	

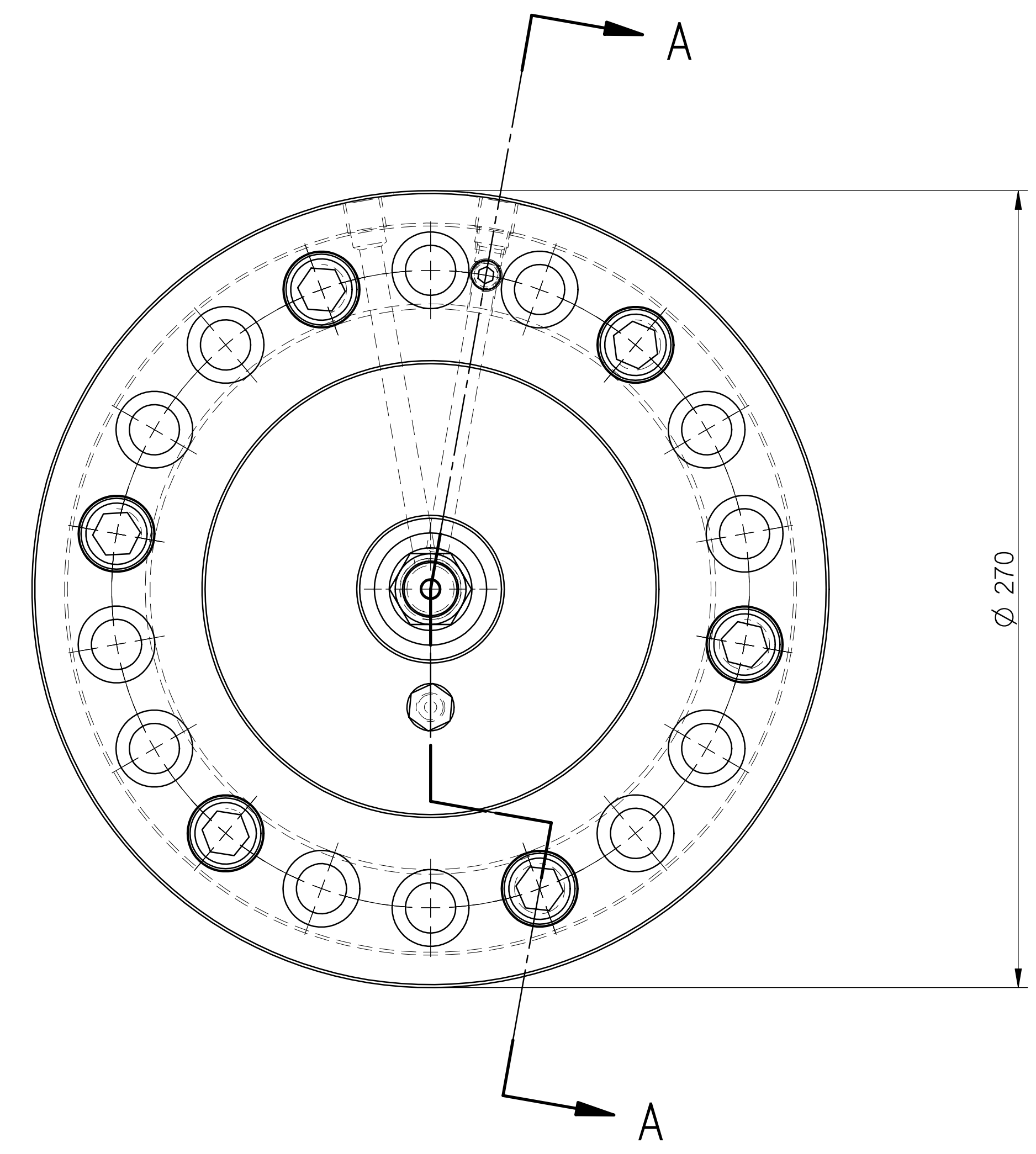
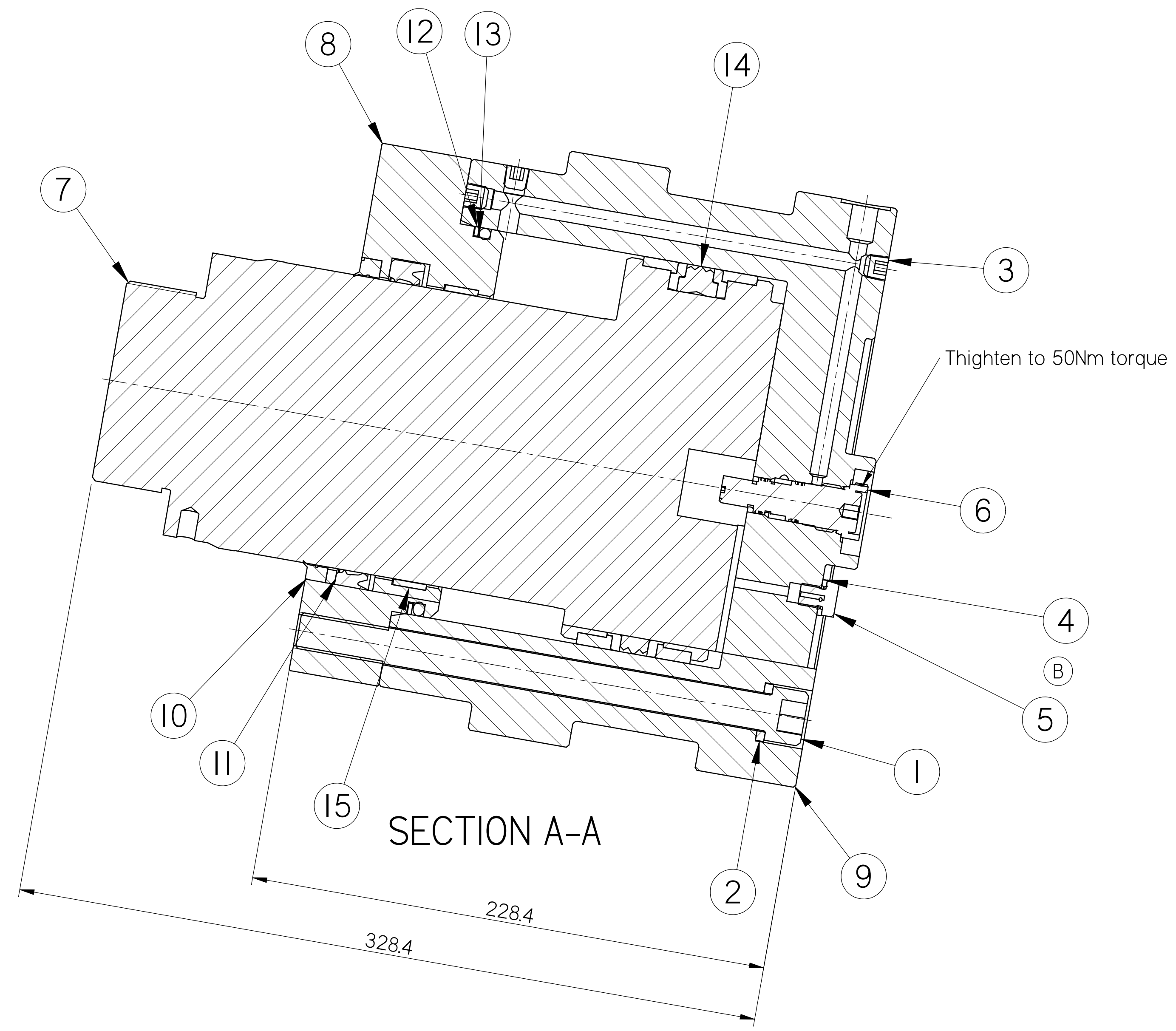
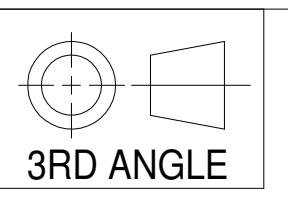

SEE SEAL KIT  
5616.01

15	1	Rod Bearing Strip	BT25150		5616-61
14	1	Double acting piston seal	PCB0A1900-NC RO		5616-18
13	1	O-Ring	190 x 5		5616-17A
12	1	O-Ring Anti Extrusion Ring	Ø190		5616-17
11	1	ROD SEAL	150/130/15mm	CPU 590511	5616-16
10	1	PU WIPER METAL CASED PRESS FIT	PFP 130146		5616-15
9	1	Cylinder Housing	EN14		5616-11
8	1	GLAND	EN14		5616-10
7	1	Piston Rod	En24T		5616-08
6	1	Check Valve Cartridge	ERVE-G1/2"	HYDAC	4616-2
5	1	1/8" BSP BLEED PLUG		1/8" BSP	4116-2
4	1	1/8" BSP Dowty Washer			1.114.03.01
3	3	BLANKING PLUG		1/8" BSPT	1-018-22-01
2	6	NORD-LOCK WASHER		M16	0M16.000.27
1	6	SOCKET HEAD CAP SCREW			0M16-210-02

General Notes:-  
Approximate weight 84Kg  
When Pressure testing after initial build to 350 Bar

SURFACE FINISH UNLESS STATED OTHERWISE	MACHINING TOLERANCES UNLESS STATED OTHERWISE
▽ ROUGH MACHINE N9	X = +/- 0.5
▽▽ FINE MACHINE N8	X . X = +/- 0.25
▽▽▽ GRIND N6	X . XX = +/- 0.05
	ANGLES +/- 0.5°
	DIMENSIONS IN MILLIMETERS

Ref.no.	Qnt.	Part name	Material	Dimension	Remark
Design by peter watts	Drawn by peter watts	Copied -	Checked -	Standard A2	Affirmed -
DAWSON CONSTRUCTION PLANT LTD.			Clamp Cylinder EMV550		Scale -
Sheet 1 of 1				Date 05/10/2020	Replaced by -
Drawing no. 5616					



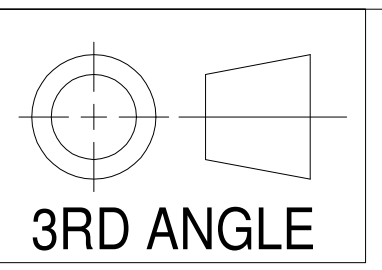

Rf.nr	Qnt.	Revision	Date	Intro.	Appr.by
A		ITEMS 9 AND 26 SCREW LENGTHS INCREASED	040609		PLW
B		REVISE GENERAL NOTES	130614		MDB
C		CHANGE DOWTY WASHER	12/05/22		MDB

NOTES:-  
 EMV550 = 546 kN CENTRIFUGAL FORCE  
 CLAMPING FORCE = 655 kN @ 230 Bar  
 APPROX. WEIGHT = 435Kg

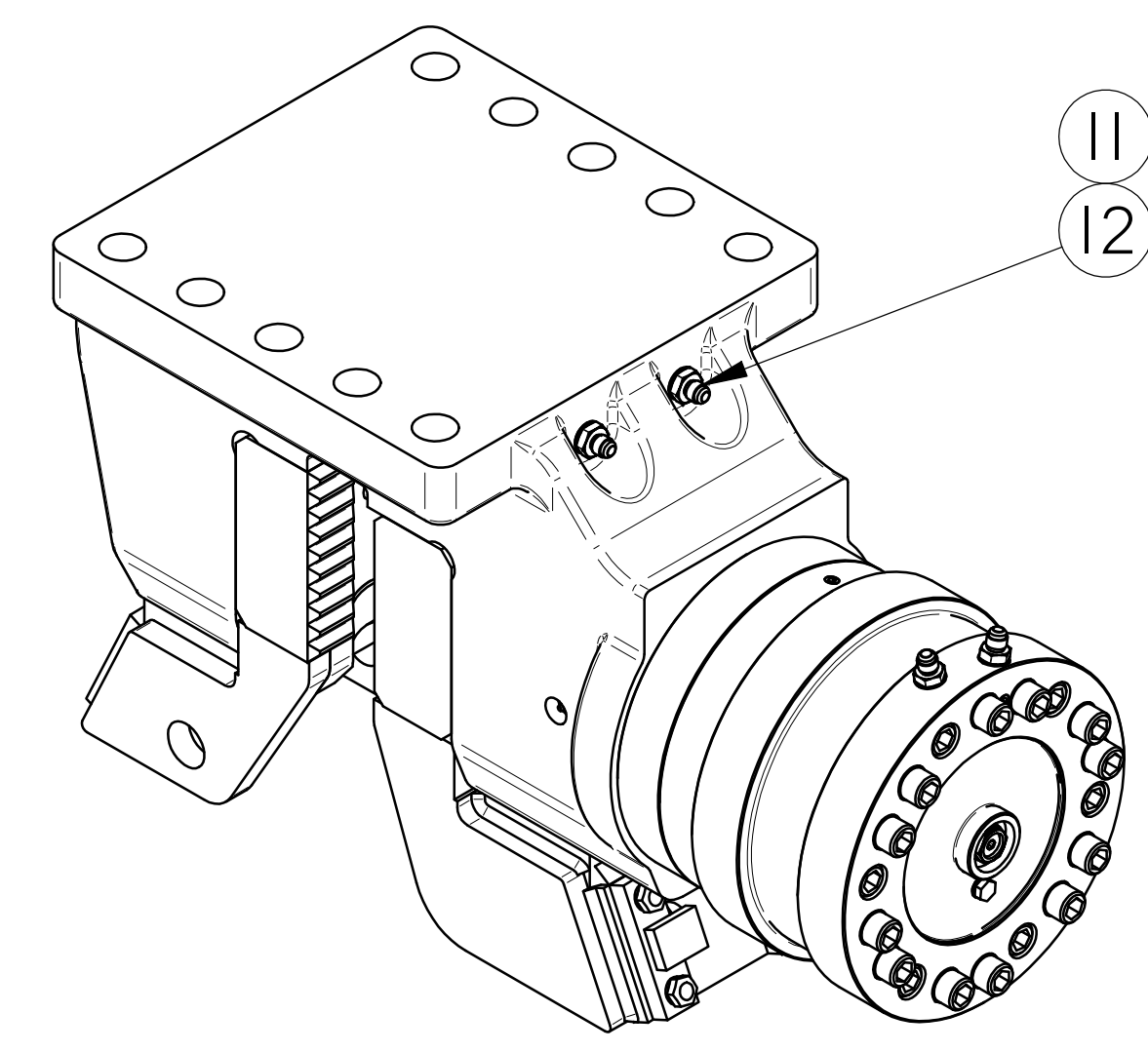
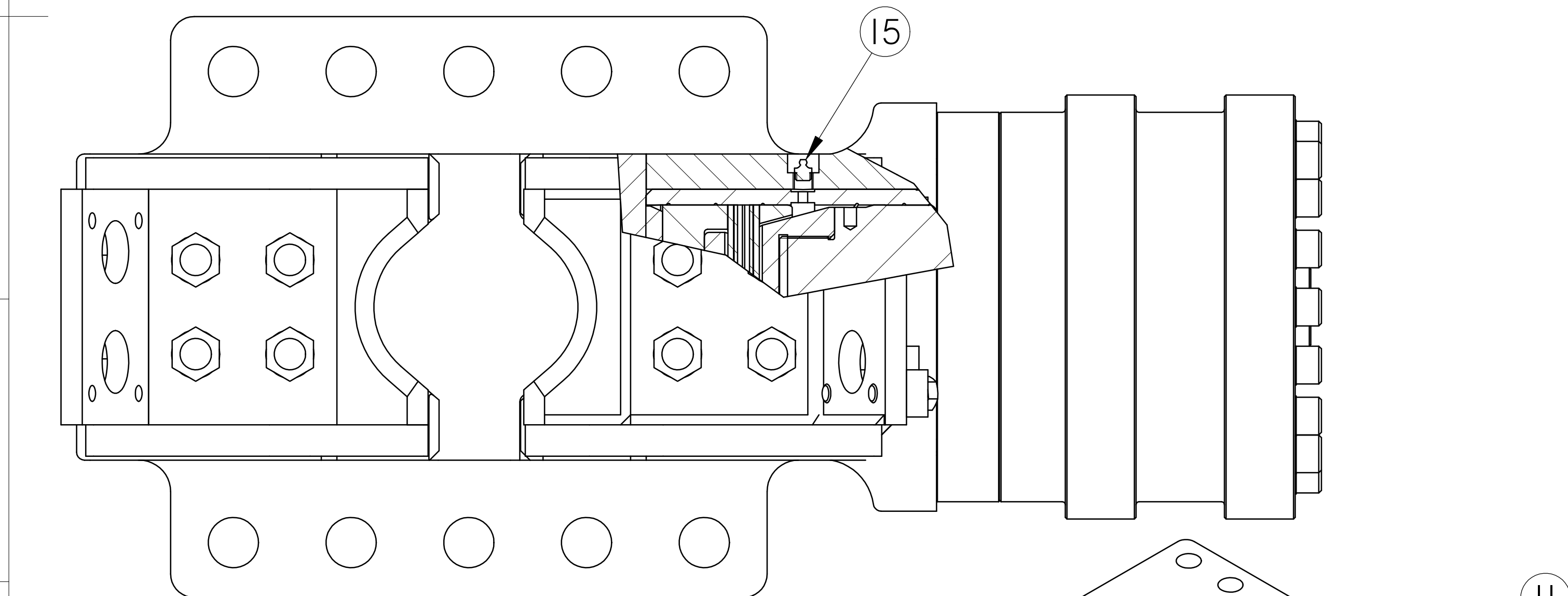
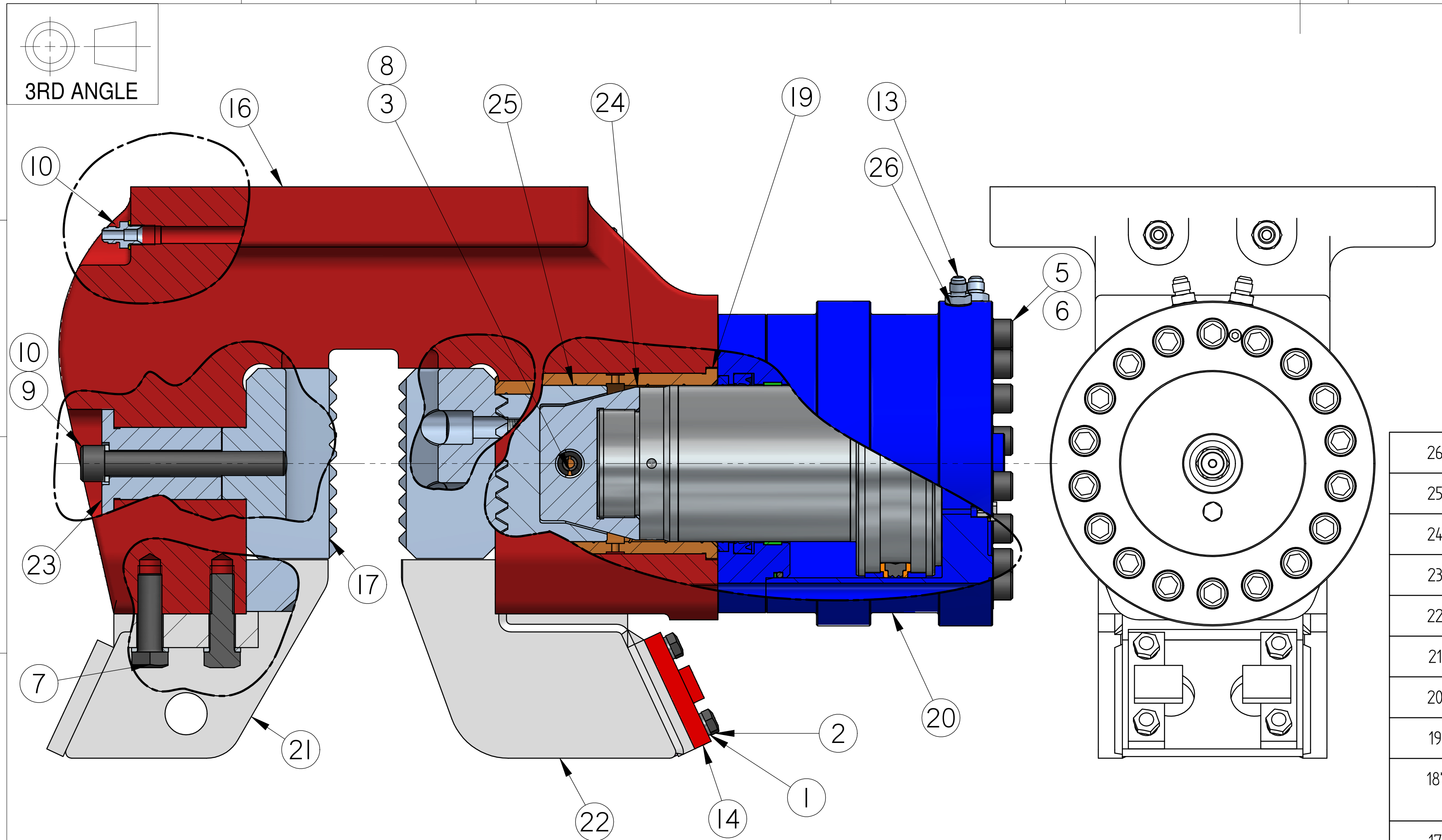

Ref.no.	Qnt.	Part name	Material	Dimension	Remark
26	2	DOWTY WASHER		0.250"	H00127
25	1	Jaw Pad Support	EN24T		5761-1
24	1	Adaptor	GRADE B02		5760
23	1	Headed Bush	EN1A		5685
22	1	Chain Holder			5684M
21	1	Chain Holder			5684
20	1	Clamp Cylinder			5616
19	1	Bush	BRONZE GRADE LB4		5615
18	1	Moving Jaw Pad	EN36B CASE HARDENED		5614-1
17	1	Fixed Jaw Pad EMV550	EN36B CASE HARDENED		5613-1
16	1	Clamp Body Machined Casting	BS31000 GRADE BT2		5612D
15	1	STRAIGHT GREASE NIPPLE		M10	4767
14	2	Chain Clamp	BS 4360 GRADE 50B		4682
13	2	MB4/MJ6 1/4"BSP -9/16" JIC			4279
12	4	MB6/MJ6 3/8"BSP -9/16" JIC			4217A
11	4	Dowty Seal - 3/8" BSP		(CF6 3801)	1-100-01-01
10	9	NORD-LOCK WASHER		M20	0M20.000.27
9	1	SOCKET HEAD CAP SCREW		M20 x 150 LG	0M20-150-02
8	1	Spring Pin		Φ20 x 130	0M20-130-22
7	8	HEX HD BOLT		M20 x 65Lg	0M20-065-01
6	13	NORD-LOCK WASHER		M16	0M16.000.27
5	12	SOCKET HEAD CAP SCREW		M16 x 250Lg	0M16-250-02
4	1	SOCKET HEAD CAP SCREW	12.9	M16 x 60 LG	0M16-060-02
3	1	Spring Pin		Φ12 x 130	0M12-130-22
2	4	HEX HD BOLT	8.8	M12 x 35LG	0M12-035-01
1	4	NORD-LOCK WASHER		M12	0M12-000-27

SURFACE FINISH UNLESS STATED OTHERWISE		MACHINING TOLERANCES UNLESS STATED OTHERWISE	
▽	ROUGH MACHINE N9	X = +/- 0.5	
▽▽	FINE MACHINE N8	X.X = +/- 0.25	
▽▽▽	GRIND N6	X.XX = +/- 0.05	
		ANGLES +/- 0.5°	
		DIMENSIONS IN MILLIMETERS	

Ref.no.	Qnt.	Part name	Material	Dimension	Remark	
Design by	MarkBramley	Drawn by	MarkBramley	Copied	-	
		Checked	-	Standard	A3	
		Affirmed	-	Scale	-	
					Replace	-
					Replaced by	-
Clamp Assembly EMV 550					Sheet	1 of 1
					Drawing no.	
						5618D

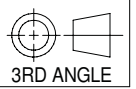

8	9	10
Rf.nr	Qnt.	Revision
		Date
		Intro.
		Appr.by

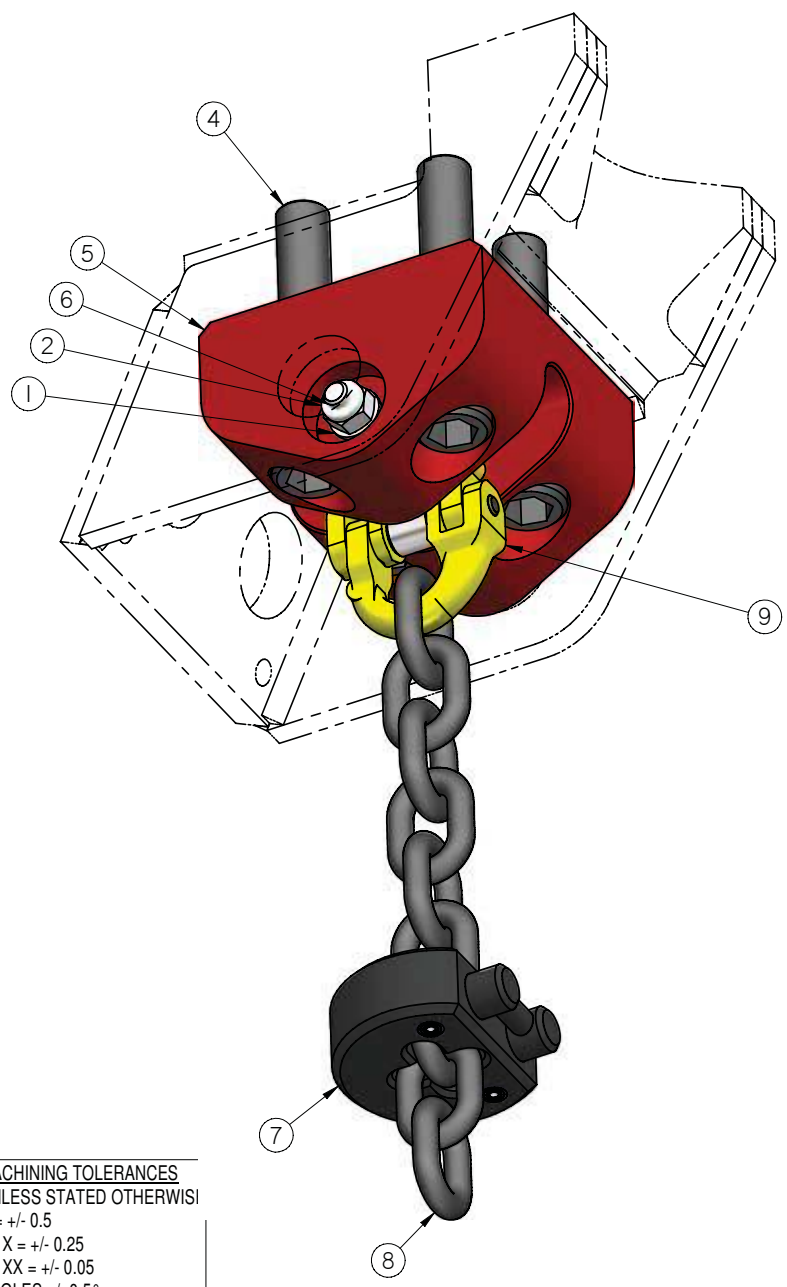

SWL for chain adaptor with 10mm chain is  
3.2 Tonne.  
Pull to 6.4 Tonne for proof Load

To prove design Pull to 16 Tonne and hold  
for 5 minutes.

10*	1	SLEEVE				TLR368
9	1	G10 Chain Coupler				TLR362
8	1	10mm Chain				TLR361
7	1	10mm Chain Clamp				TLR360
6	1	SOCKET HEAD CAP SCREW				OM10-100-02
5	1	EMV400 SINGLE CHAIN ADAPTOR	EN50B FLAME CUT	Z4684-001-01		4684-001-01
4	4	SOCKET HEAD CAP SCREW	12.9	M20 x 100		OM20.100.02
3*	4	NORD-LOCK WASHER		M20		OM20-000-27
2	1	NYLOC NUT		M10		OM10.000.11
1	2	WASHER		M10		OM10-000-20

<b>SURFACE FINISH</b> UNLESS STATED OTHERWISE	<b>MACHINING TOLERANCES</b> UNLESS STATED OTHERWISE
▽ ROUGH MACHINE N9	X = +/- 0.5
▽ FINE MACHINE N8	X . X = +/- 0.25
▽ GRIND N6	X . XX = +/- 0.05
	ANGLES +/- 0.5°
	DIMENSIONS IN MILLIMETERS

Ref.no.	Qnt.	Part name	Material	Dimension	Remark
Design by peter watt	Drawn by peter watt	Copied -	Checked -	Standard A3	Affirmed -
Scale -					Replace -
Replaced by -					Sheet 1 of 1
Date 04/08/2010					Drawing no. 4684 ADPT



DAWSON  
CONSTRUCTION  
PLANT LTD.

Single chain adaptor assy

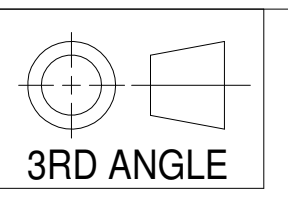

Ref.no	Qnt.	Revision	Date	Intro.	Appr.by
A		UPDATED TO BUILT MACHINE	22/01/21	MDB	
B		CHANGE TO BUSH NUMBER	21/07/21	MDB	

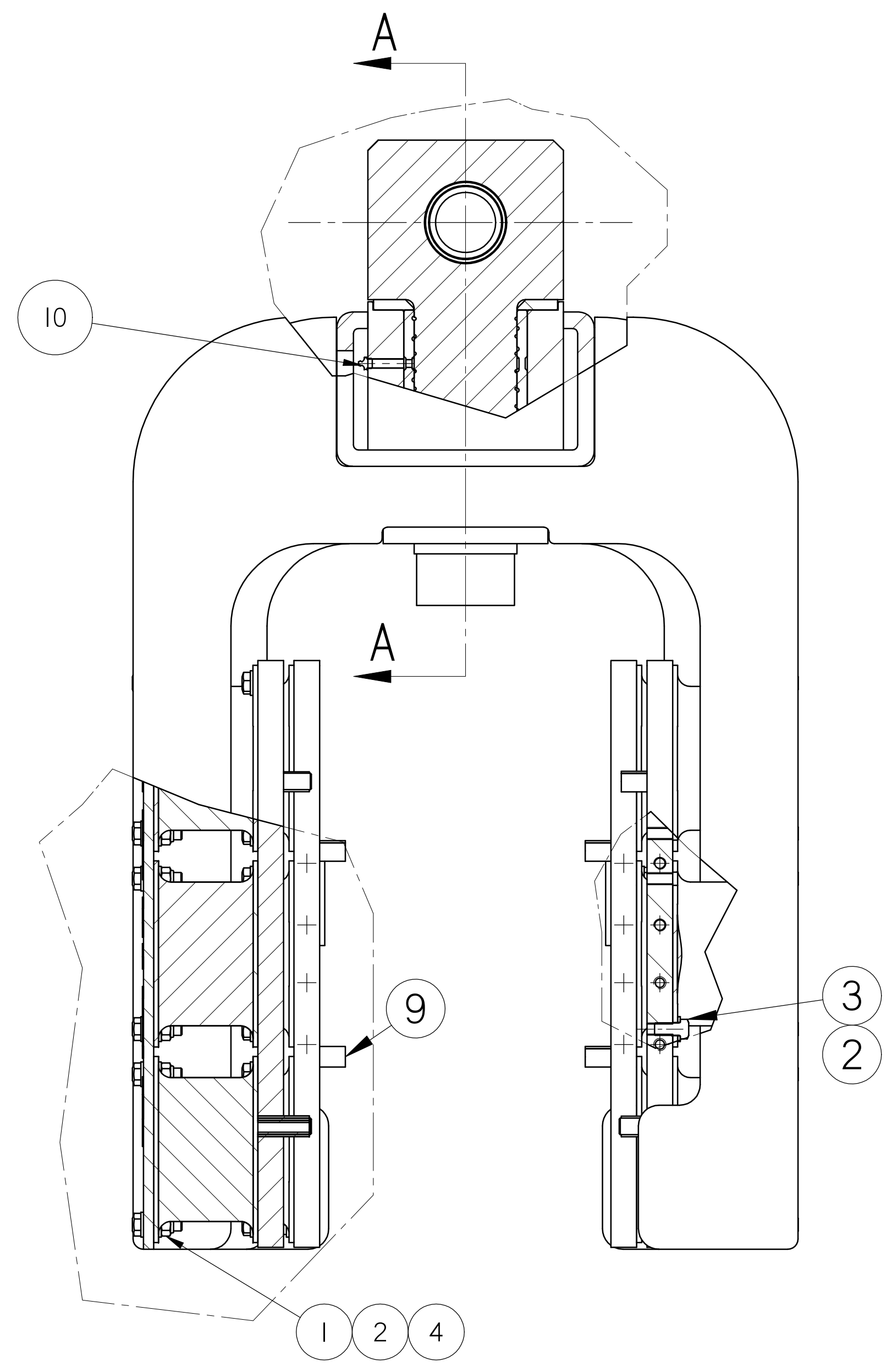
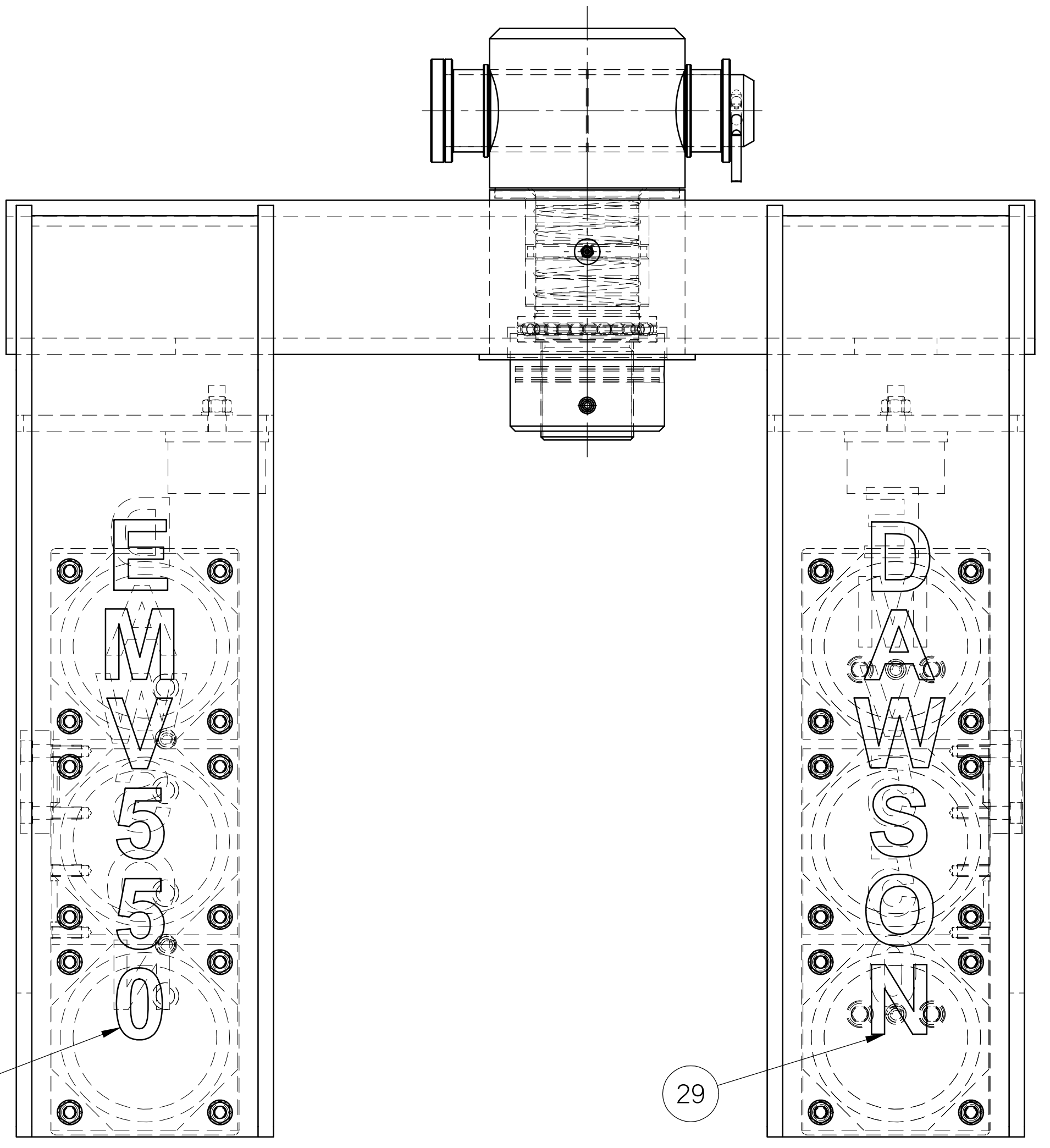
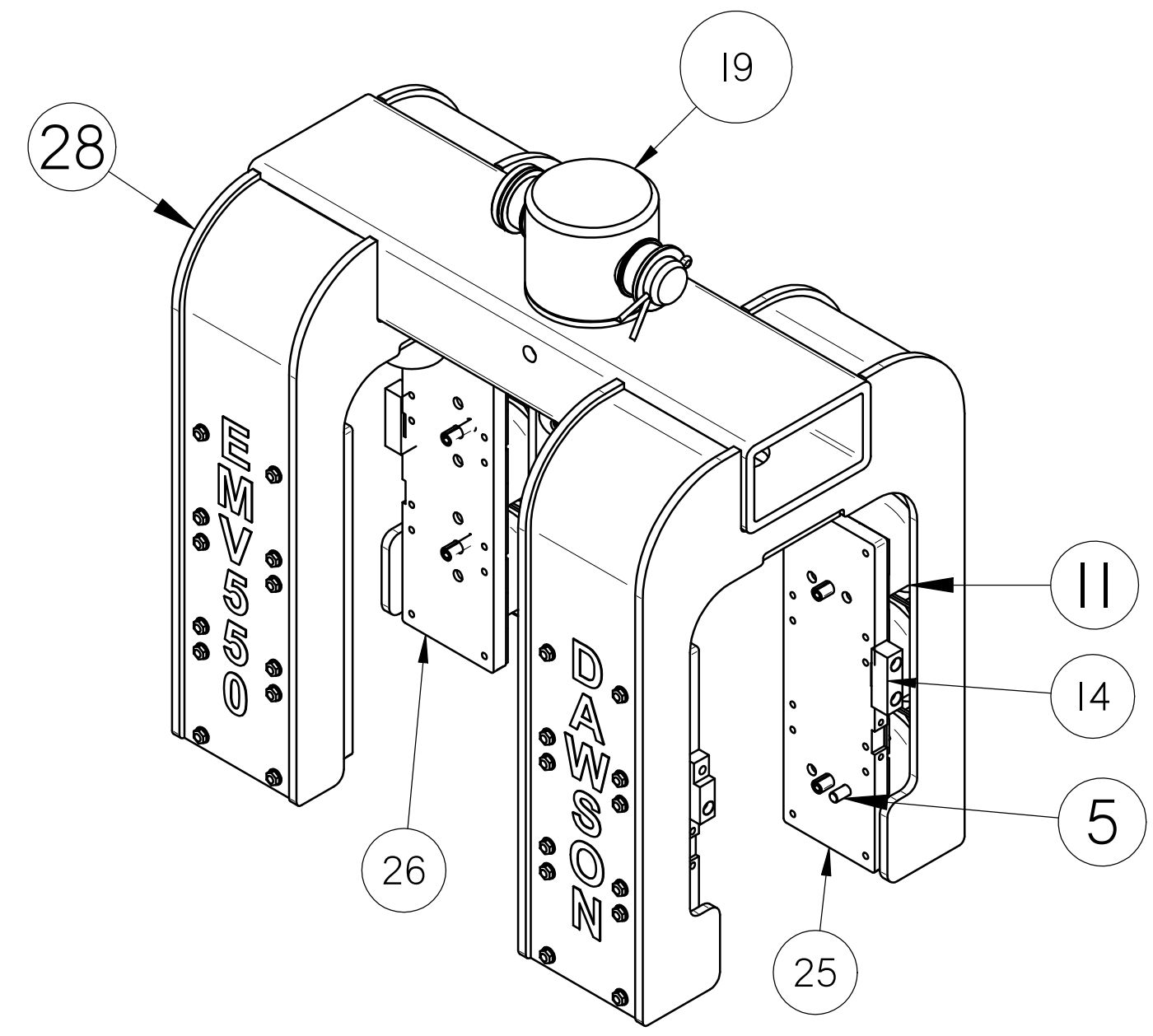
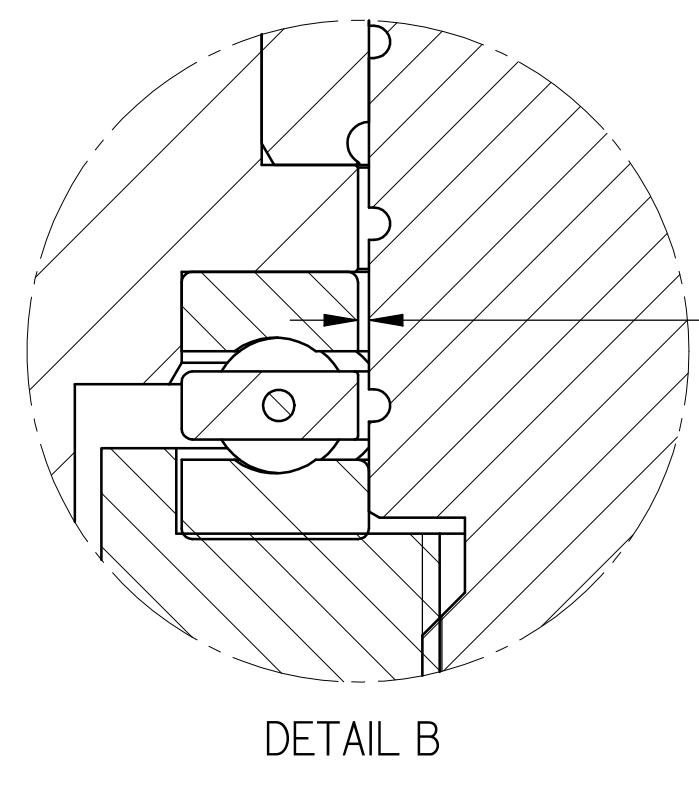
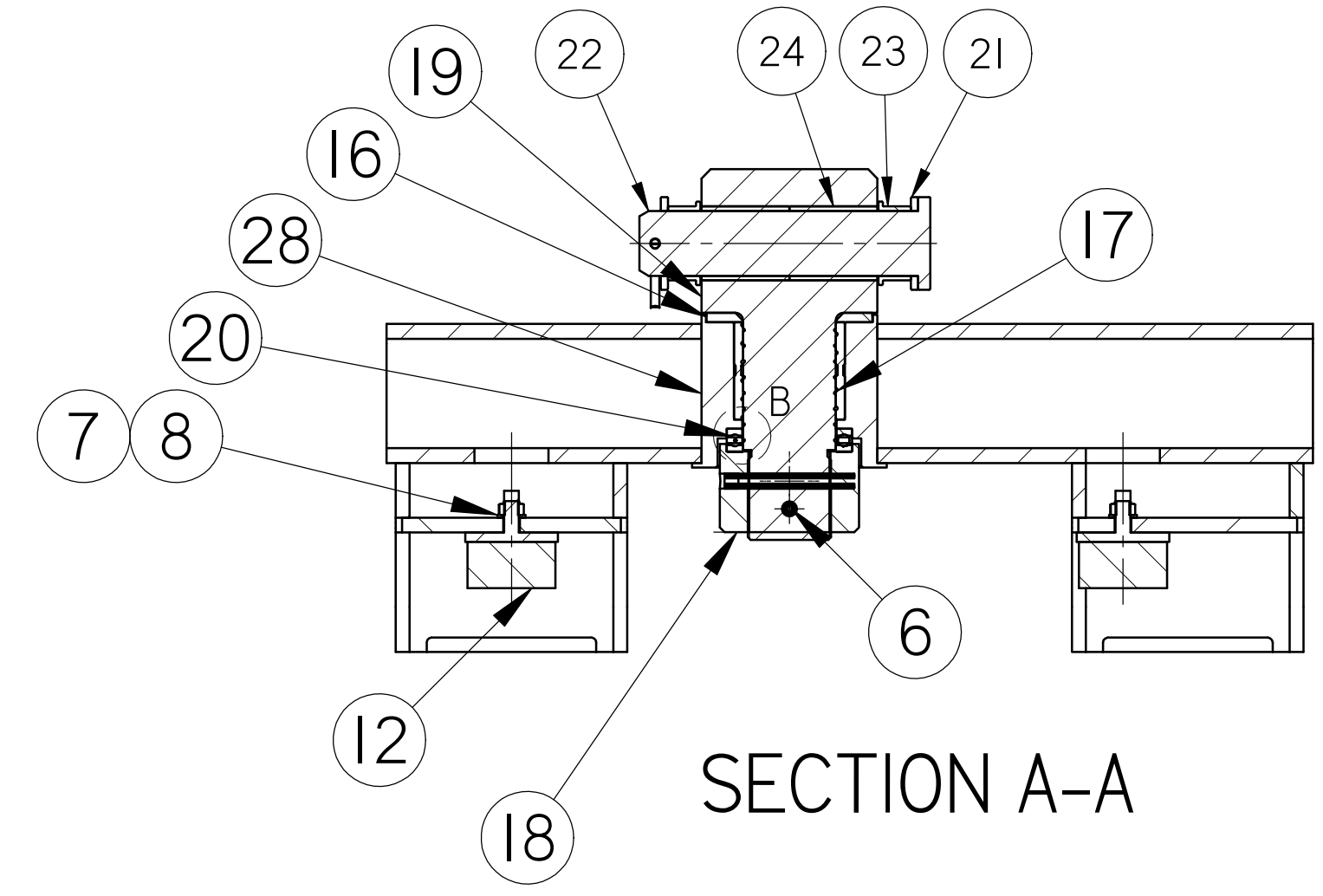
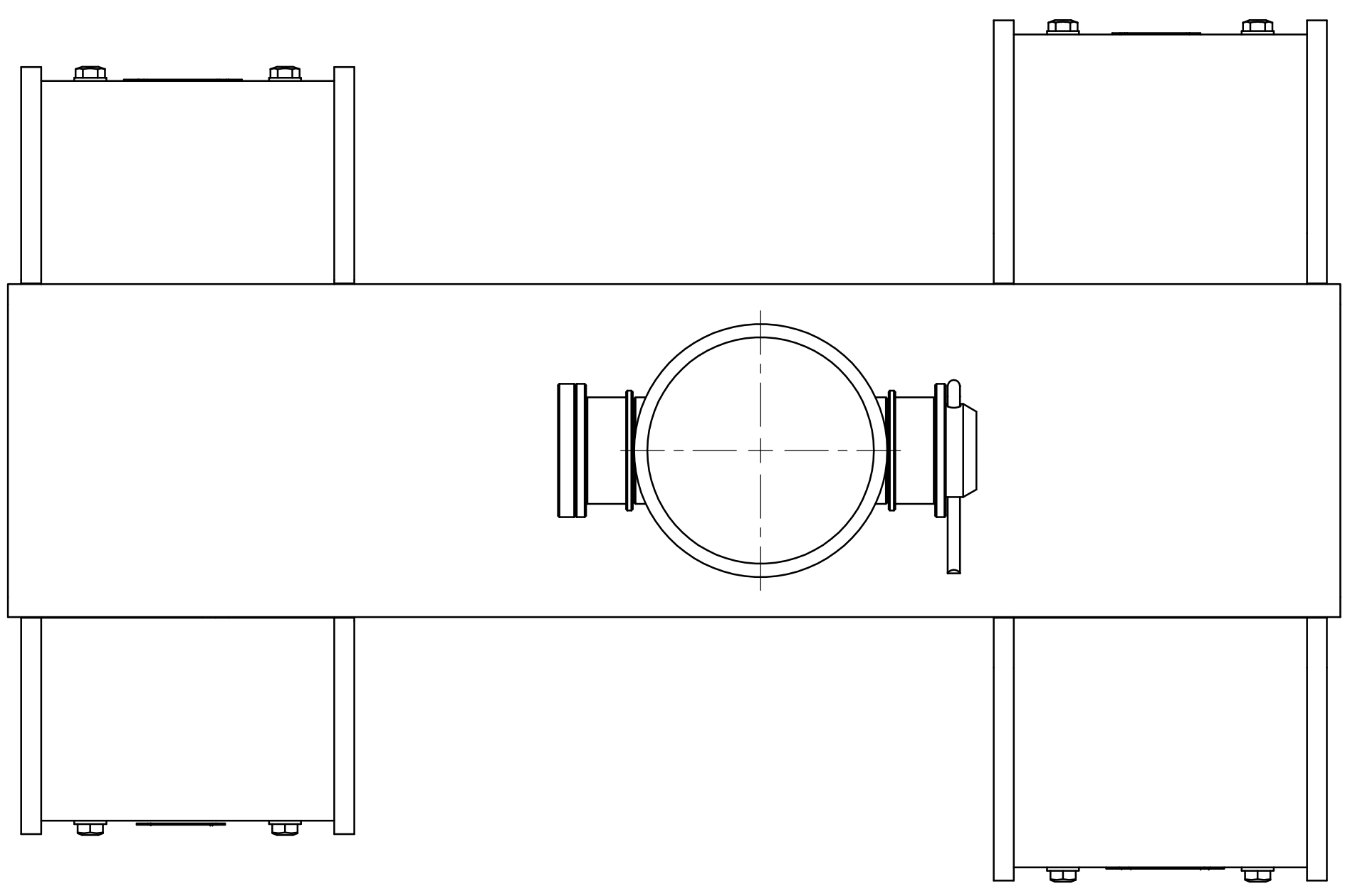

Ref.no	Qnt.	Part name	Material	Dimension	Remark
29	2	Dawson Sticker			Dawson Sticker
28	1	EMV550 SADDLE			5617-2
27	2	550 Sticker			550 Sticker
26	2	SANDWICH MOUNT ADAPTOR	EN50B		5104A
25	2	SANDWICH MOUNT ADAPTOR	EN50B		5104
24	2	SLEEVE			5069
23	2	FLANGED BUSH			5068
22	1	SHEAR PIN			5066
21	2	SPACER			5065
20	1	BALL THRUST BEARING		51120	5026
19	1	LIFTING BOLT			5024
18	1	NUT			5023
17	1	BUSH			5022-1
16	1	THRUST WASHER			5021
15	1	CATCHER BLOCK - MILLED			4106-1
14	3	STOP			4106
13	1	SPLIT PIN			4067
12	2	BUFFER			4028
11	12	SANDWICH MOUNTING			4025A
10	1	GREASE NIPPLE	1/8" BSP		1-057-00-01
9	8	COILED PIN	∅ 20 x 50 LG		0M20-050-36
8	2	WASHER	M16		0M16.000.20
7	2	NYLOC NUT - TYPE T	M16		0M16.000.12
6	2	COILED SPRING PIN			0M16-140-36
5	16	SOCKET HEAD CAP SCREW	M16 x 35 LG		0M16-035-02
4	48	HEX HD BOLT	10.9	M12 x 40LG	0M12.040.01
3	0	HEX HD BOLT	ST.STEEL	M12 x 25LG	0M12.025.04
2	144	WASHER	ST.STEEL	M12	0M12.000.20
1	48	NYLOC NUT - TYPE T	M12		0M12-000-12

SURFACE FINISH		MACHINING TOLERANCES	
UNLESS STATED OTHERWISE		UNLESS STATED OTHERWISE	
▽	ROUGH MACHINE N9	X	+/- 0.5
▽▽	FINE MACHINE N8	X . X	+/- 0.25
▽▽▽	GRIND N6	X . XX	+/- 0.05
			ANGLES +/- 0.5°
			DIMENSIONS IN MILLIMETERS

Design by	Drawn by	Copied	Checked	Standard	Affirmed	Scale	Replace	Replaced by
PLW	PLW	-	-	A2	-	-	-	-
<b>DAWSON CONSTRUCTION PLANT LTD.</b>							<b>Saddle Assembly</b> <b>EMV 550</b>	
							Sheet 1 of 1	Date 15/06/2009
							Drawing no.	5620



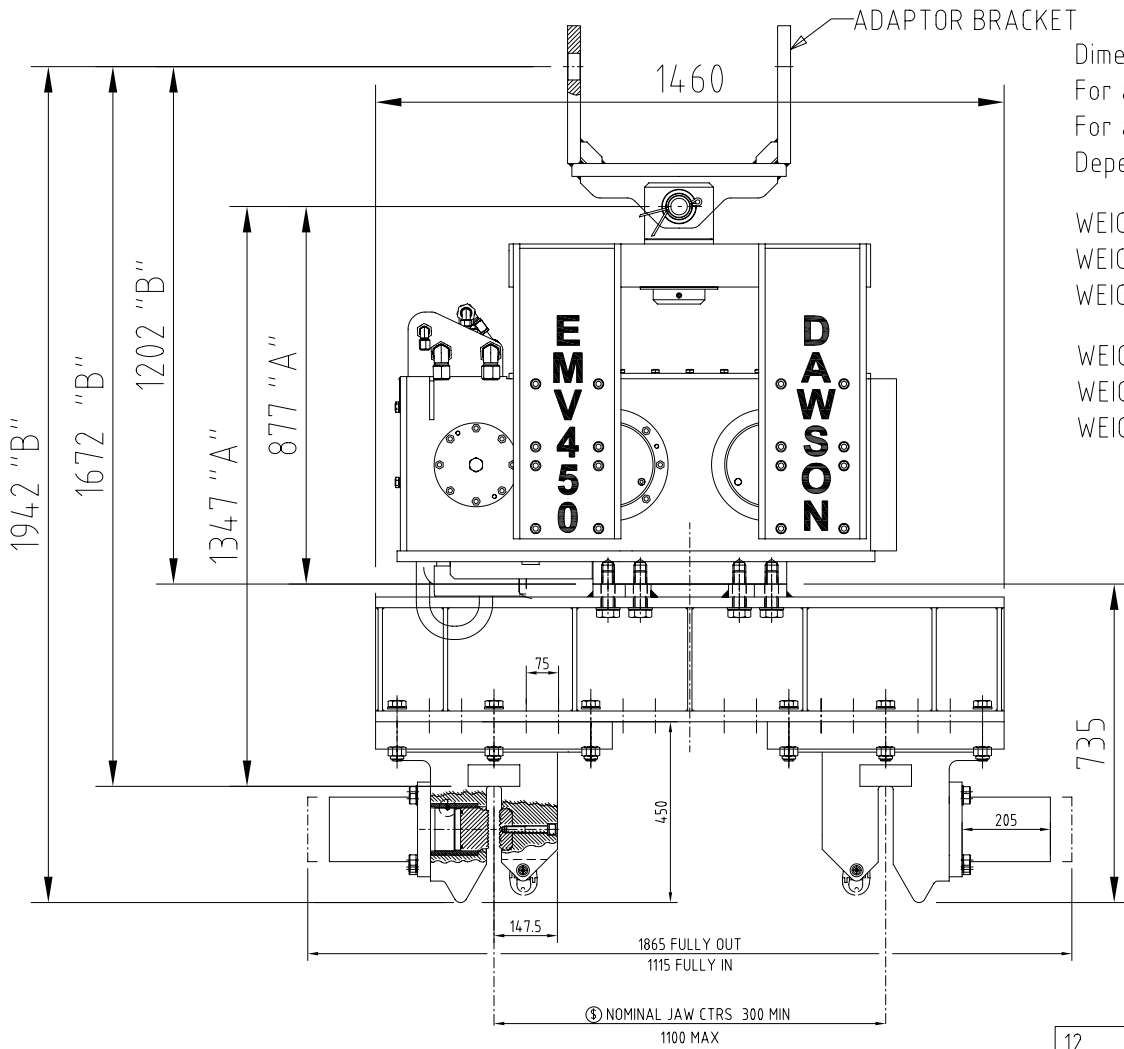

Dimensions shown are for an EMV450  
 For an EMV550 + 125MM DIM "A" AND +175mm DIM "B"  
 For an EMV300 - 52mm OR - 140mm DIM "A" AND "B"  
 Depending on SADDLE TYPE

WEIGHT EMV300 = 1500 Kg + ADAPTOR BRACKET  
 WEIGHT EMV450 = 1700 Kg+ ADAPTOR BRACKET  
 WEIGHT EMV550 = 1800 Kg+ ADAPTOR BRACKET

WEIGHT CSV300 = 2027 Kg + ADAPTOR BRACKET  
 WEIGHT CSV450 = 2247 Kg+ ADAPTOR BRACKET  
 WEIGHT CSV550 = 2634 Kg+ ADAPTOR BRACKET

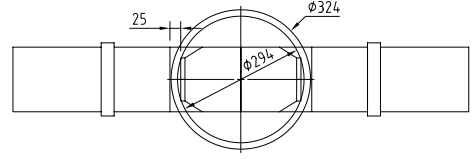
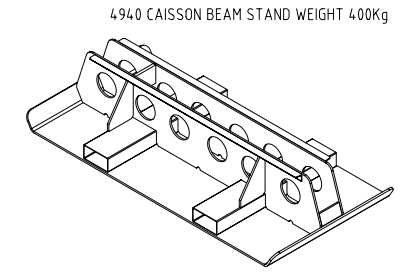
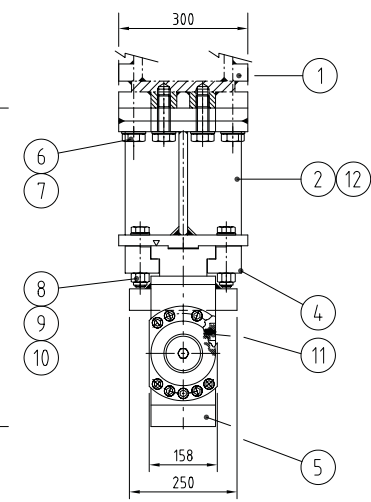

③ JAW ADJUSTMENT DETAILS:  
 EACH JAW ASSEMBLY MAY BE POSITIONED ALONG THE BEAM IN 75mm PITCHES.  
 EACH JAW CAN BE MOVED +/- 50mm FOR EACH CLAMPED POSITION TO ACHIEVE A FULL RANGE  
 OF INFINITELY VARIABLE POSITIONS WITHIN THE LIMITS NOTED ABOVE.

12	A/R	PAINT FINISH				TO CUSTOMERS ORDER
11	A/R	GREASE				
10	12	PLAIN WASHER		M24	2-087-00-01	
9	12	NYLOC NUT		M24	0M24.000.11	
8	12	HEX HD BOLT	8.8	M24 X 125	0M24.125.01	
5	2	JAW ASSEMBLY			4 018C	
4	4	GIB STRIP			4 912	
2	1	BEAM WELD ASSEMBLY			4 910	
1	1	EMV 400 GEARBOX				

Ref.no.	Qnt.	Part name	Material	Dimension	Part number
Design by	Drawn at	Copied	Checked	Standard	Affirmed
WJW				A3	
DAWSON CONSTRUCTION PLANT LTD.			EMV 300/450/550 TO CAISSON BEAM		File name 4900.DWG
					Date 05-05-99
					Drawing no. 4900 issue D

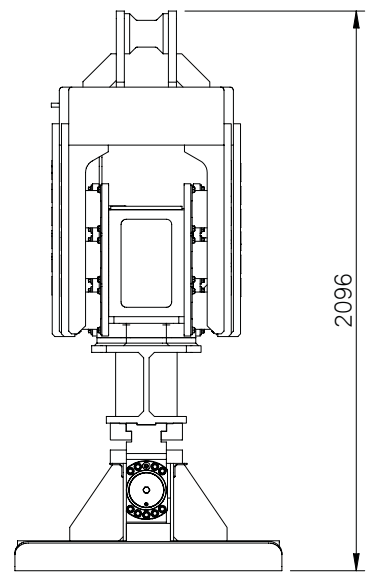
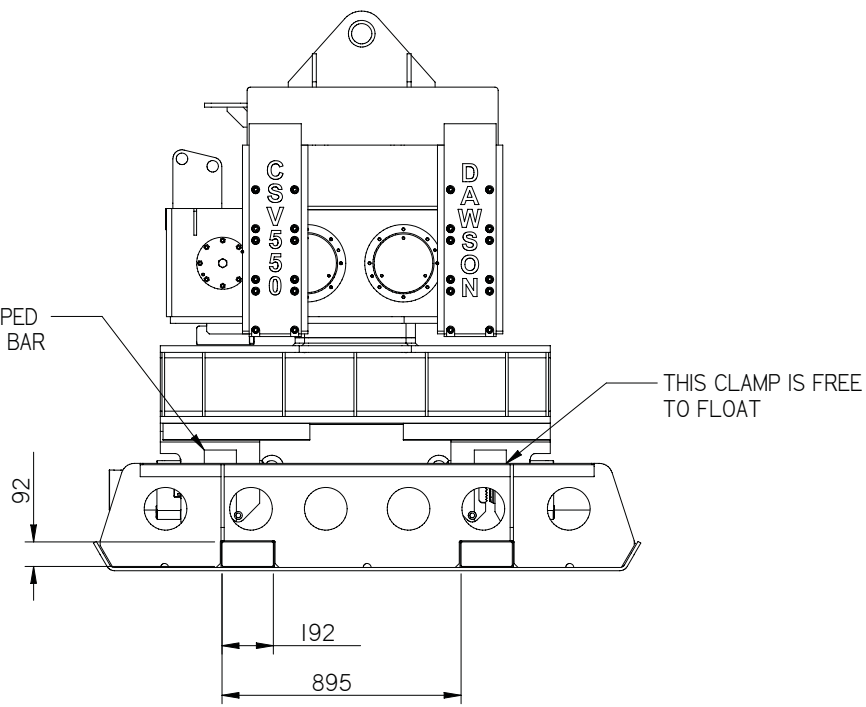
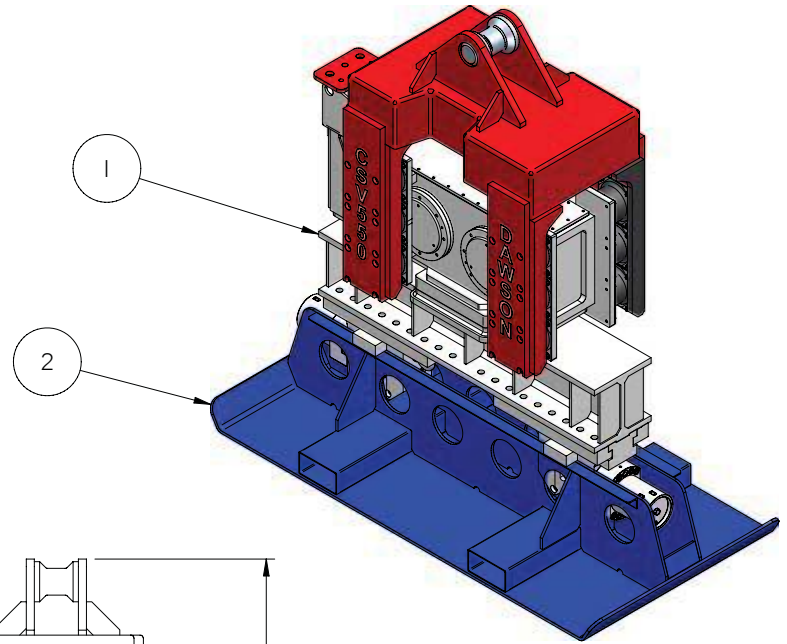
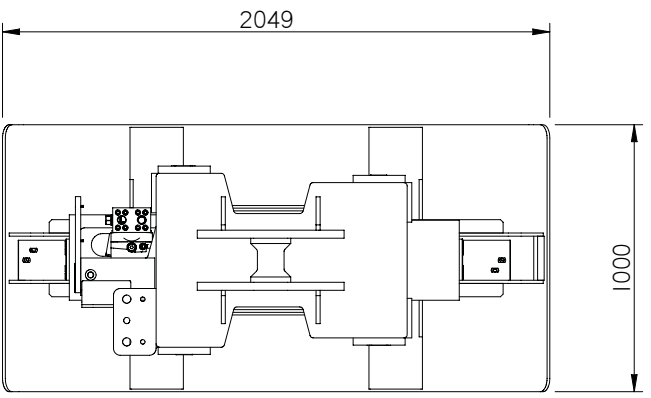
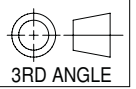

SURFACE FINISH UNLESS STATED OTHERWISE		MACHINING TOLERANCES UNLESS STATED OTHERWISE	
▽	ROUGH MACHINE N9	X	X = +/- 0.5
▽▽	FINE MACHINE N8	X . X	X = +/- 0.25
▽▽▽	GRIND N6	X . XX	X = +/- 0.05
		ANGLES +/- 0.5°	
		DIMENSIONS IN MILLIMETERS	

2	1	CAISSON Stand	EN43A		4940
1	1	CAISSON CLAMP SET			4900
Ref.no.	Qnt.	Part name	Material	Dimension	Remark
Design by MDB	Drawn by MDB	Copied -	Checked -	Standard A3	Affirmed -
DAWSON CONSTRUCTION PLANT LTD.			EMV550		Replace - Replaced by - Sheet 1 of 1 Date 25/03/2011 Drawing no. 5941

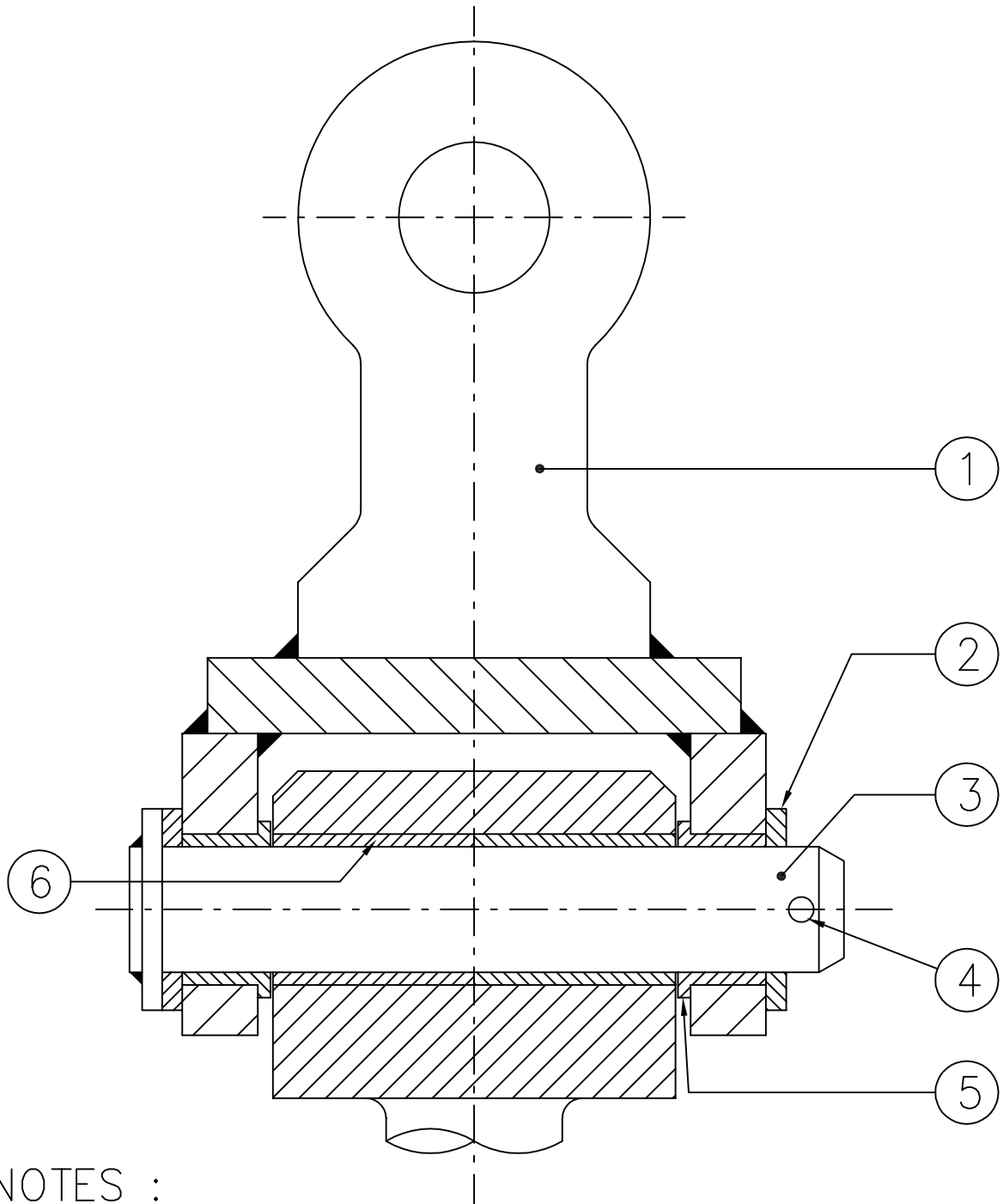

NOTES :

-THIS DRAWING MUST NOT BE REPRODUCED BY ANY MEANS WITHOUT PRIOR PERMISSION OF THE COPYRIGHT OWNER

6	2	SLEEVE			5069
5	2	FLANGED BUSH			5068
4	1	SPLIT PIN	$\phi 3/8" \times 5"$		4067
3	1	SHEAR PIN			5066
2	2	SPACER			5065
1	1	ADAPTOR BRACKET			5063

Ref.no.	Qnt.	Part name	Material	Dimension	Remark
Design by	Drawn at	Copied	Checked	Standard	Affirmed
M.LEE					
				Scale	1 : 2.5
				Replace	Replaced by
				File name	Date 03-5-11
				Drawing no	5064



DAWSON  
CONSTRUCTION  
PLANT LTD.

ADAPTOR BRACKET  
ATTACHMENT

Rf.r	Qnt.	Revision	Date	Intro.	Appr. by
A		CYLINDER VALVE CHANGED	031110	PLW	

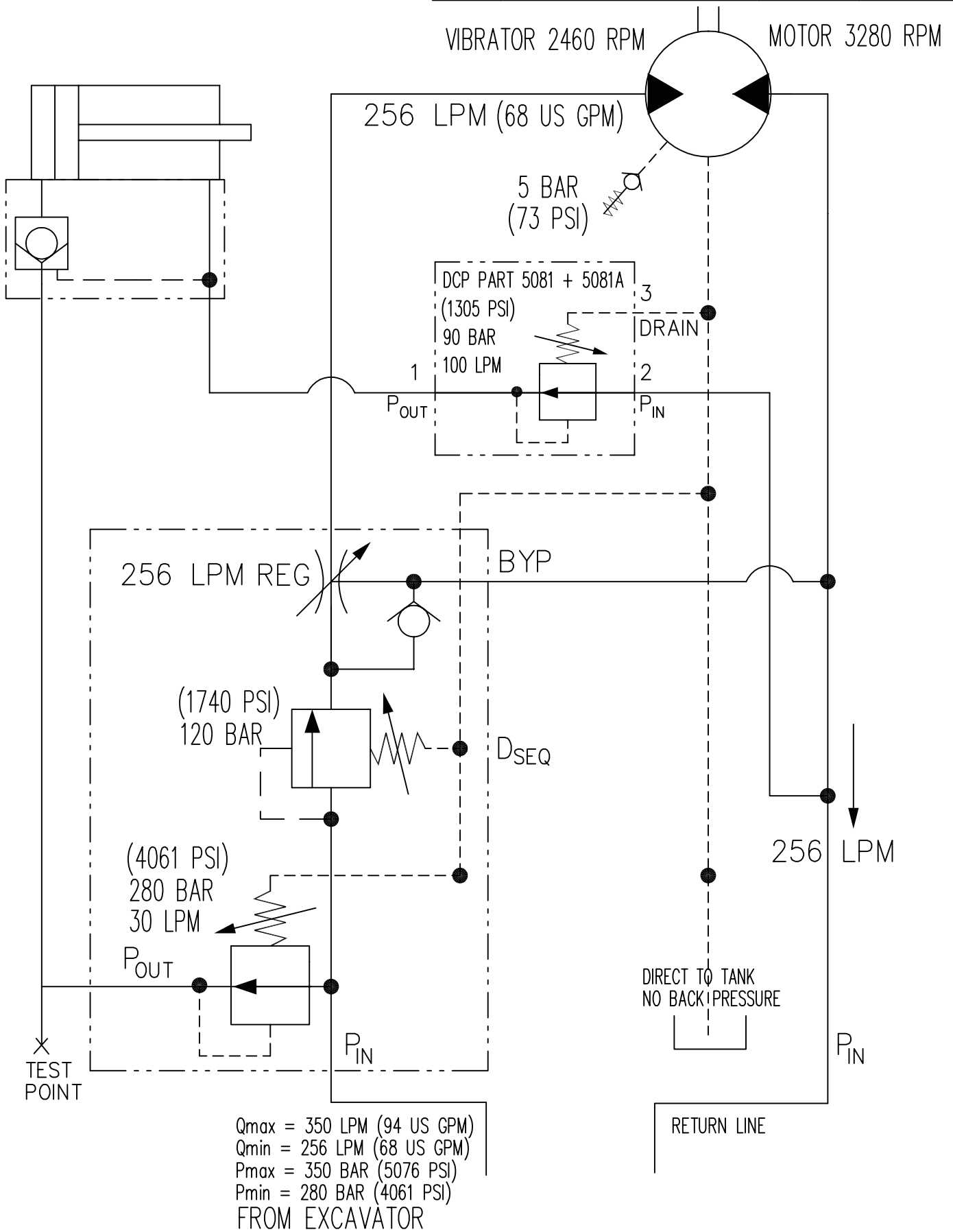

Design by PLW	Drawn at	Copied	Checked	Standard A4	Affirmed	Scale	Replace	Replaced by	
 DAWSON CONSTRUCTION PLANT LTD.							File name	Date 23-09-10	
HYDRAULIC CIRCUIT SCHEMATIC - EMV550							Drawing no. emv550hydcir		



Sequence valve  
11.5mm (default setting)



Clamp Pressure Limiter  
12mm (default setting)

Flow Regulator  
12-13mm (default setting)



Flow Compensator  
8.5mm (default setting)

# appendix a- auxiliary equipment

---



---

---

---

---

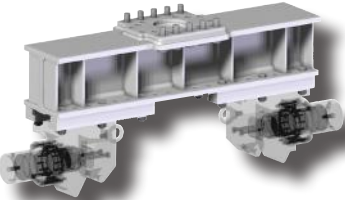
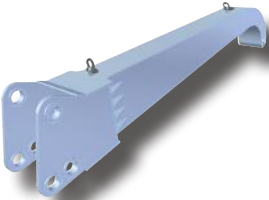
# EMV - AUXILLARY EQUIPMENT

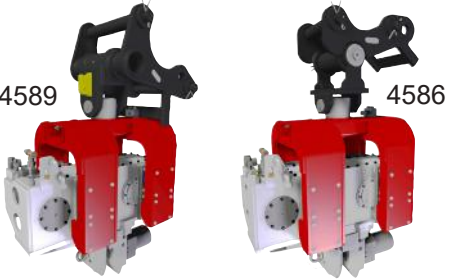
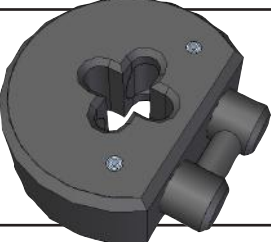
ITEM	DESCRIPTION	ITEM No.	WEIGHTS														
	<p><b>CAISSON BEAM</b> Caisson beam jaw assemblies can be positioned to suit any tube size between Ø300 I.D &amp; Ø1100 mm O.D.</p>	4900	<p>Weight EMV300 = 1500kg + (adaptor bracket)</p> <hr/> <p>Weight EMV450 = 1700kg + (adaptor bracket)</p> <hr/> <p>Weight EMV550 = 1800kg + (adaptor bracket)</p>														
	<p><b>SWAN NECK</b> For extended reach and greater pile clearance on your excavator arm, enabling longer piles to be driven.</p>	<p>4939</p> <hr/> <p>4932</p> <hr/> <p>4931</p>	<p>1.5m = 340kg</p> <hr/> <p>2m = 470kg</p> <hr/> <p>4m = 1100kg</p>														
	<p><b>ADAPTOR BRACKETS</b> A range of brackets to suit the EMV connection to various size excavators.</p>	4063	<p>50kg (see table on drawing 4063 summary table for all variables).</p>														
	<p><b>QUICK HITCH ADAPTOR</b> When an excavator has a guide hitch fitted and a double acting breaker to supply the EMV, the quick hitch adaptor supplies fast, easy connection to the end equipment while maintaining the same degree of movement.</p>	<p>4586</p> <hr/> <p>4589 (with intergrated adaptor bracket)</p>	<p>112kg</p> <hr/> <p>200kg</p>														
	<p><b>CHAIN CLAMP</b> For all lifting applications. The unit indexes along the links of the chain and locks into place giving a quick and simple chain lock for lifting.</p>	<p>4130</p> <hr/> <p>TLR 360</p> <hr/> <p>4082</p>	<table border="1"> <thead> <tr> <th>SWL</th> <th>WEIGHT</th> <th></th> </tr> </thead> <tbody> <tr> <td>2000kg</td> <td>1kg</td> <td>8 mm chain clamp</td> </tr> <tr> <td>3200kg</td> <td>1.2kg</td> <td>10 mm chain clamp</td> </tr> <tr> <td>8000kg</td> <td>3.7kg</td> <td>16 mm chain clamp</td> </tr> </tbody> </table>			SWL	WEIGHT		2000kg	1kg	8 mm chain clamp	3200kg	1.2kg	10 mm chain clamp	8000kg	3.7kg	16 mm chain clamp
SWL	WEIGHT																
2000kg	1kg	8 mm chain clamp															
3200kg	1.2kg	10 mm chain clamp															
8000kg	3.7kg	16 mm chain clamp															

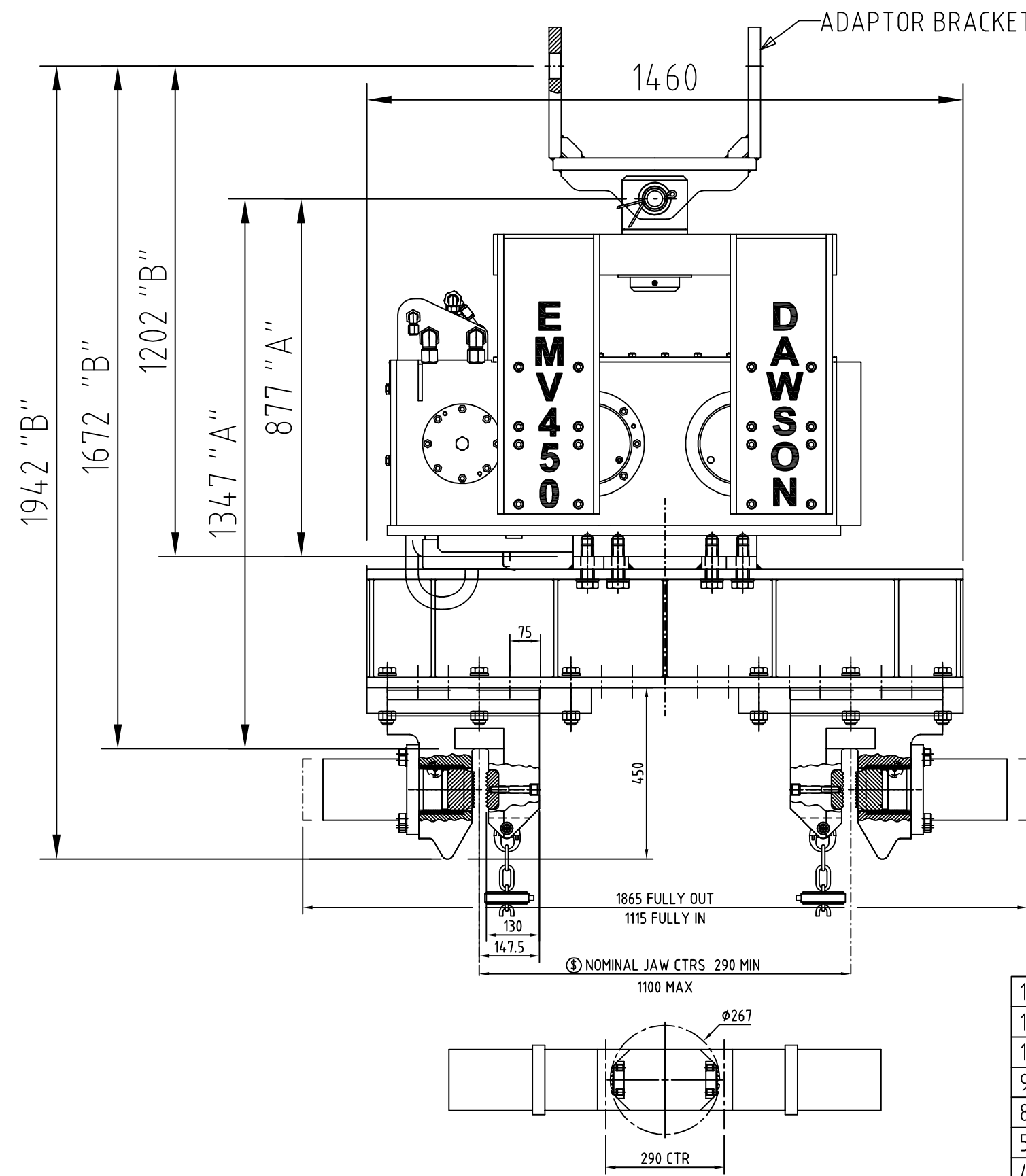

Dimensions shown are for an EMV450  
 For an EMV550 + 125MM DIM "A" AND +175mm DIM "B"  
 For an EMV300 - 52mm OR - 140mm DIM "A" AND "B"  
 Depending on SADDLE TYPE

WEIGHT EMV300 = 1500 Kg + ADAPTOR BRACKET  
 WEIGHT EMV450 = 1700 Kg+ ADAPTOR BRACKET  
 WEIGHT EMV550 = 1800 Kg+ ADAPTOR BRACKET

WEIGHT CSV300 = 2027 Kg + ADAPTOR BRACKET  
 WEIGHT CSV450 = 2247 Kg+ ADAPTOR BRACKET  
 WEIGHT CSV550 = 2634 Kg+ ADAPTOR BRACKET

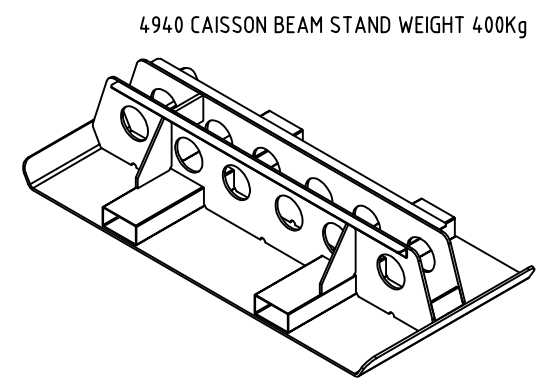
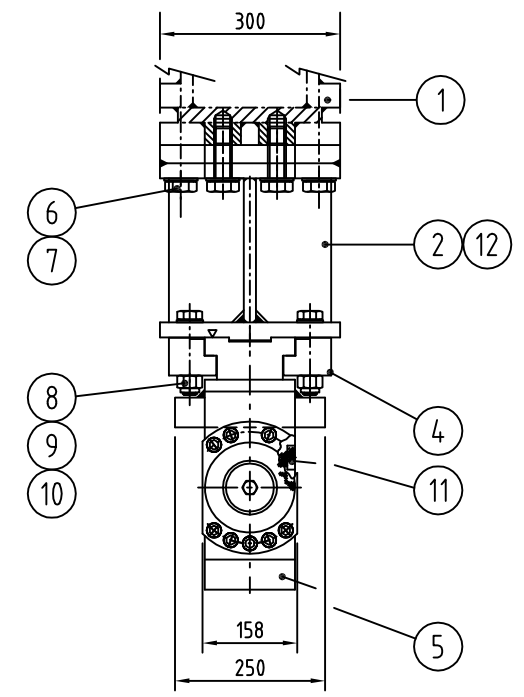

⑤ JAW ADJUSTMENT DETAILS:  
 EACH JAW ASSEMBLY MAY BE POSITIONED ALONG THE BEAM IN 75mm PITCHES.  
 EACH JAW CAN BE MOVED +/- 50mm FOR EACH CLAMPED POSITION TO ACHIEVE A FULL RANGE  
 OF INFINITELY VARIABLE POSITIONS WITHIN THE LIMITS NOTED ABOVE.

12	A/R	PAINTE FINISH			TO CUSTOMERS ORDER
11	A/R	GREASE			
10	12	PLAIN WASHER		M24	2-087-00-01
9	12	NYLOC NUT		M24	0M24.000.11
8	12	HEX HD BOLT	8.8	M24 X 125	0M24.125.01
5	2	JAW ASSEMBLY			4 018C
4	4	GIB STRIP			4 912
2	1	BEAM WELD ASSEMBLY			4 910
1	1	EMV 400 GEARBOX			

Ref.no.	Qnt.	Part name	Material	Dimension	Part number
Design by	Drawn at	Copied	Checked	Standard	Affirmed
WJW				A3	
Scale			1:8		
Replace				Replaced by	
File name				Date	
4900.DWG				12-11-12	
Drawing no.				4900 issue E	



DAWSON  
 CONSTRUCTION  
 PLANT LTD.  
 EMV 300/450/550  
 TO CAISSON BEAM



**DAWSON**  
CONSTRUCTION PLANT LTD

# CAISSON BEAM BOLT FIXING ARRANGEMENT



EMV300 CLAMP  
ARRANGEMENT



EMV450 CLAMP  
ARRANGEMENT



EMV550 CLAMP  
ARRANGEMENT



1

2

3

4

5

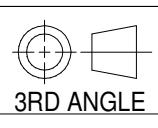

Rf.nr	Qnt.	Revision	Date	Intro.	Appr.by
-------	------	----------	------	--------	---------

A

A

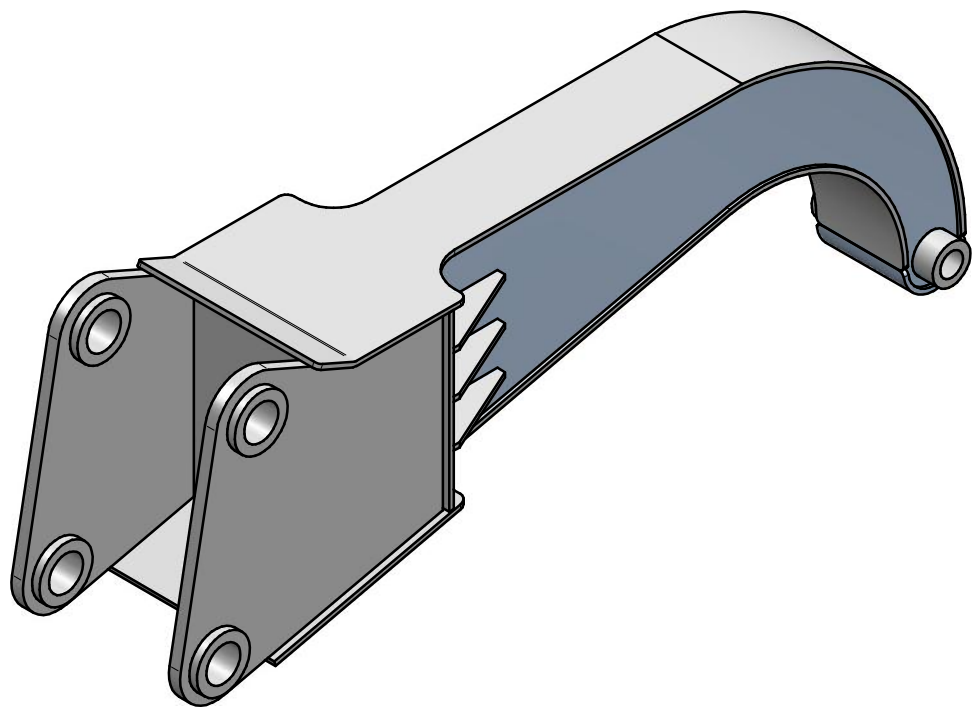

B

B

C

C

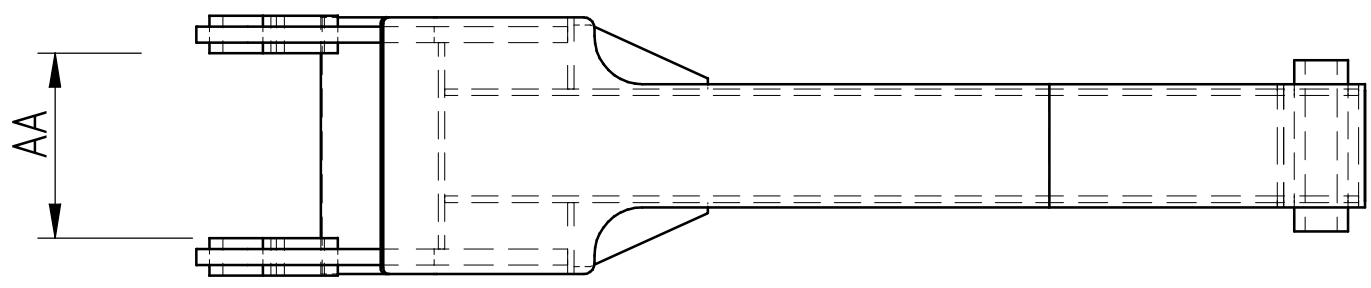

D

D

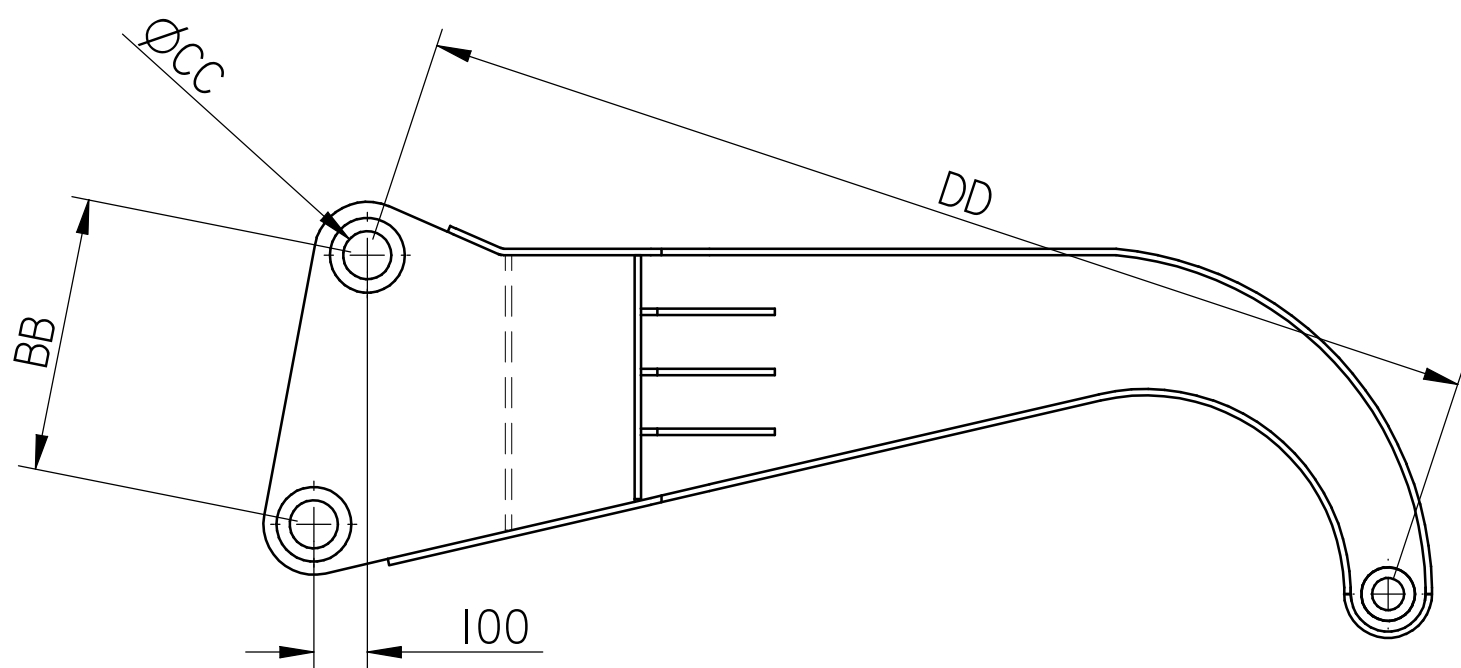

E

E

F

F

DIMENSIONS OF EXCAVATOR BUCKET CONNECTION		
	DIM MM	DIM MM
AA	346	
BB	513	
ØCCC	90	
DD	2011	

G

G

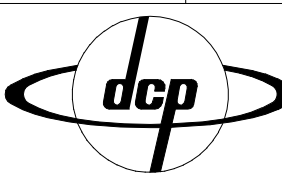
Ref.no.	Qnt.	Part name			Material	Dimension	Remark	
Design by peter watt	Drawn by peter watt	Copied -	Checked -	Standard A4	Affirmed -	Scale -	Replace -	Replaced by -
 <b>DAWSON CONSTRUCTION PLANT LTD.</b>							Sheet	1 of 1
							Drawing no.	

H

H

1

2

3

4

5

SWAN NECK DIMENSIONAL DATA



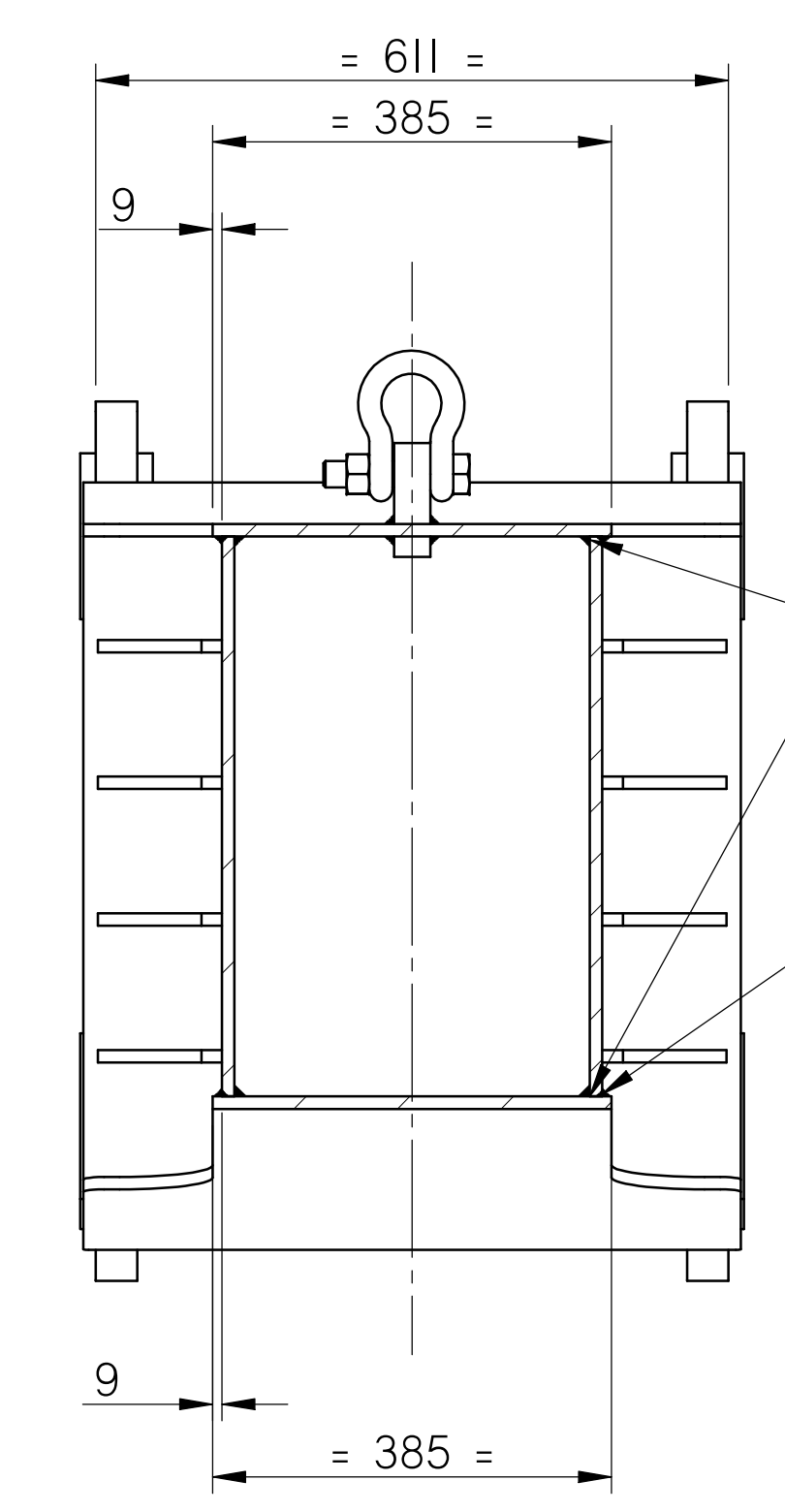
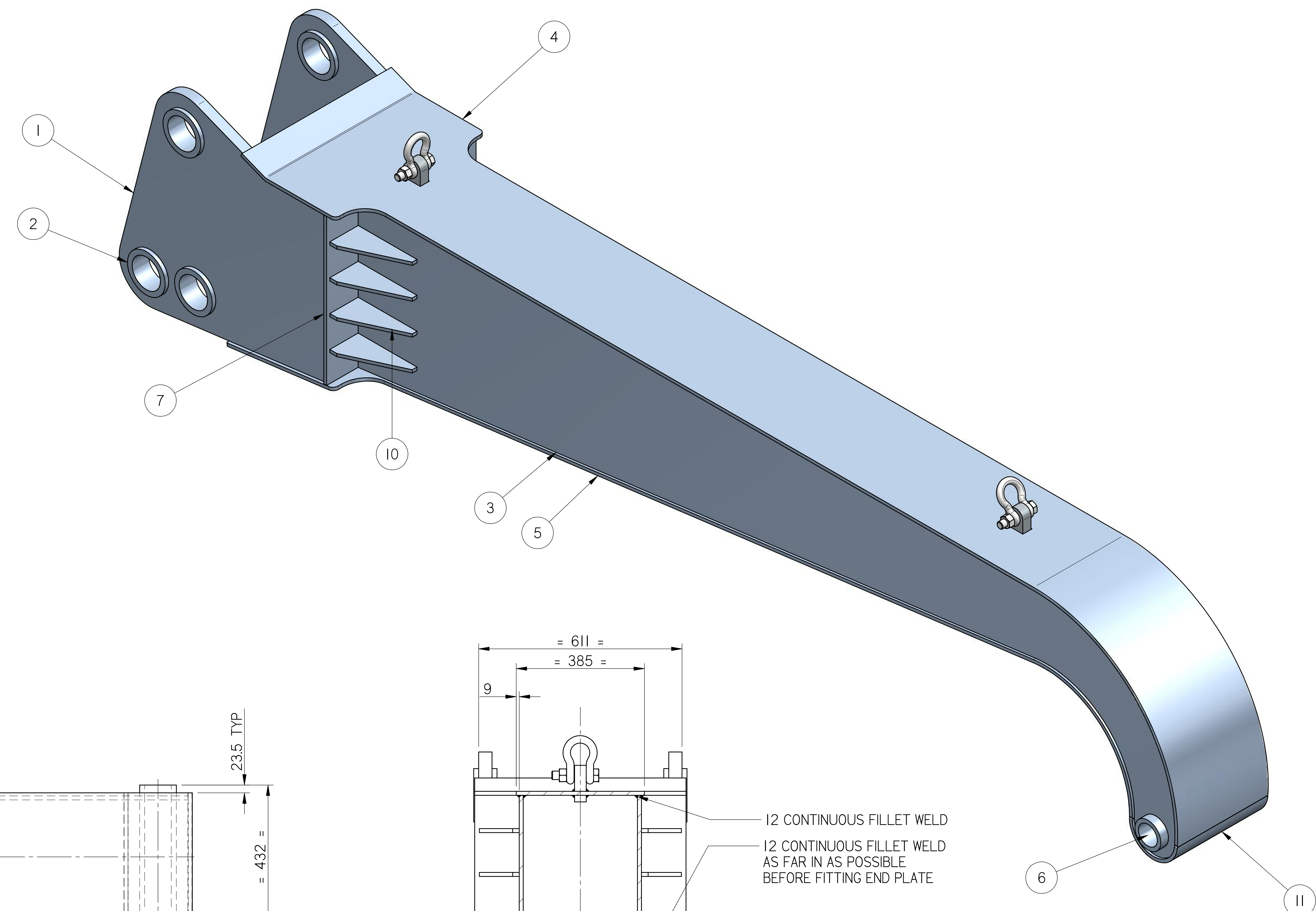
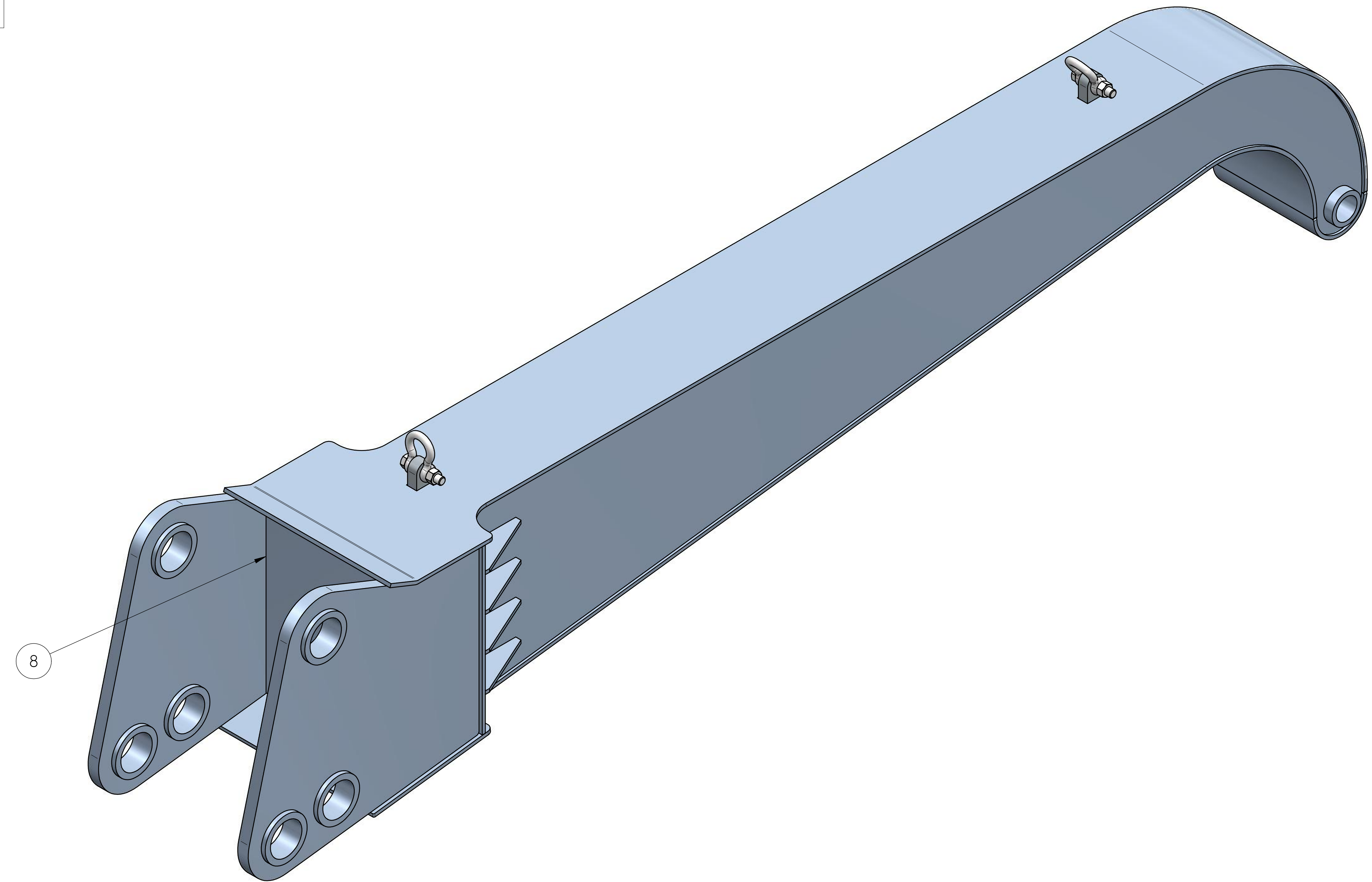
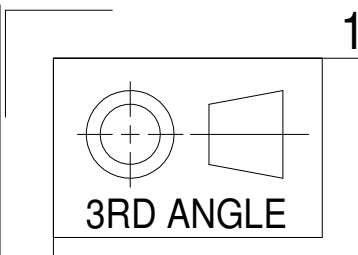

12 CONTINUOUS FILLET WELD  
 12 CONTINUOUS FILLET WELD AS FAR IN AS POSSIBLE BEFORE FITTING END PLATE  
 PREP 6MMx45° 10MM CONTINUOUS FILLET

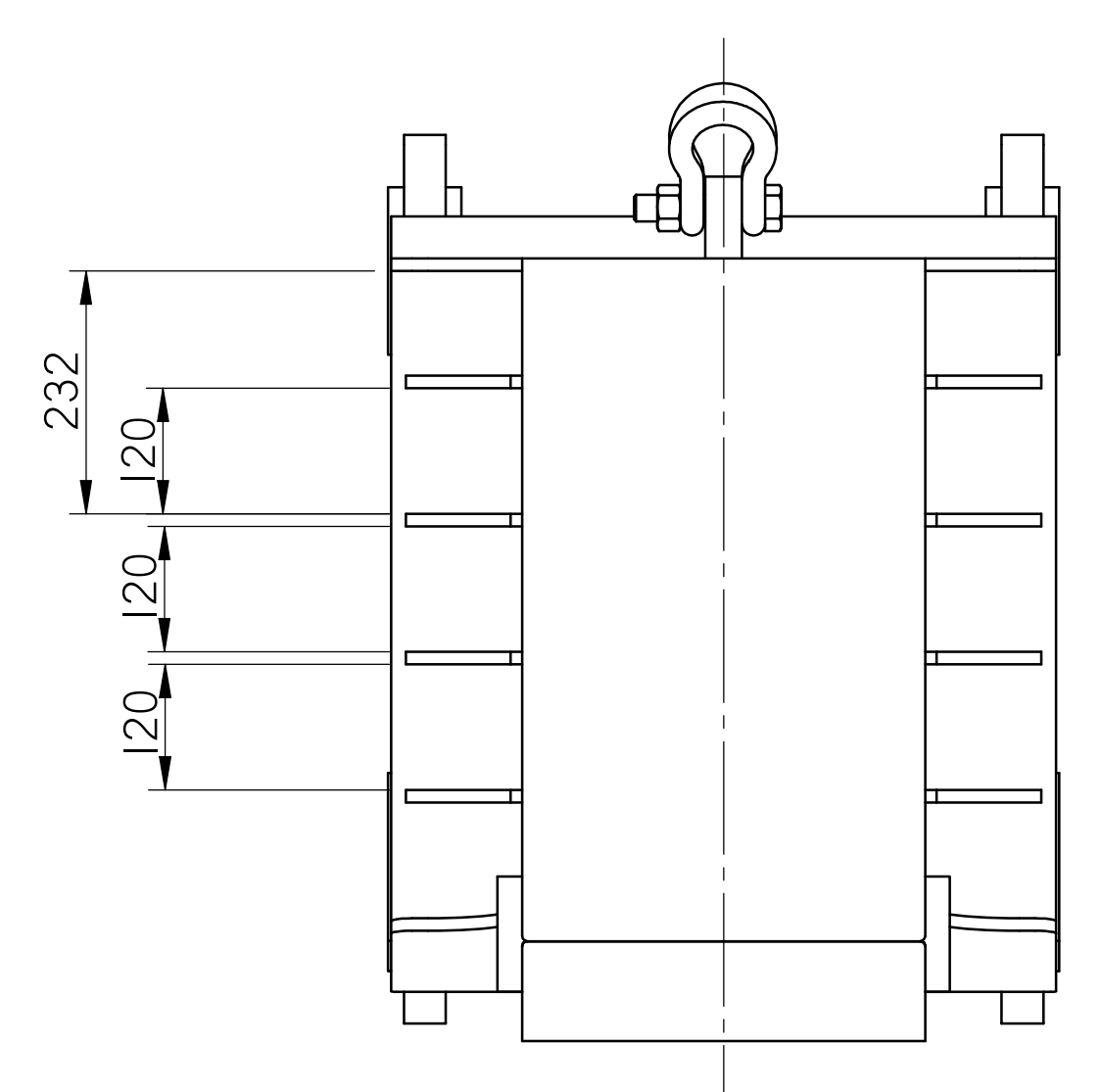
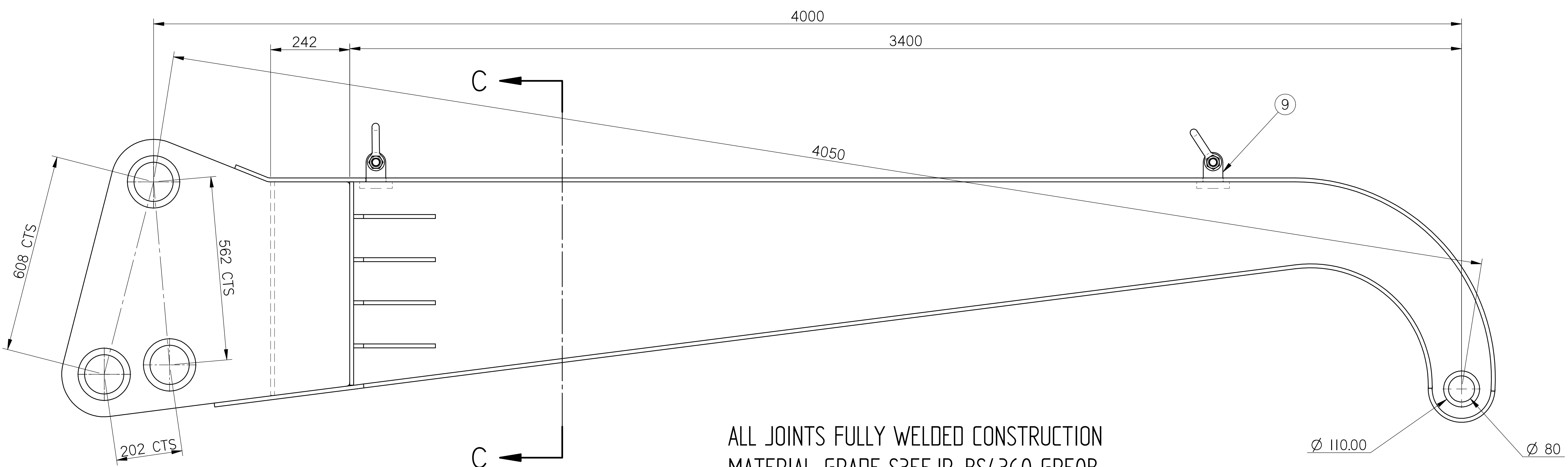

ALL JOINTS FULLY WELDED CONSTRUCTION  
 MATERIAL: GRADE S355JR, BS4360 GR50B  
 REMOVE ALL BURRS AND SHARP EDGES  
 WEIGHT 1100 KG

Ref.No.	Qnt.	Part name	Material	Dimension	Remark
11	1	PART 10			SN01-010-01
10	8	PART 9			SN01-009-01
9	2	LIFTING POINT			4931-012-01
8	1	PART 8 END PLATE			4931-008-01
7	2	PART 7			4931-007-01
6	1	PART 6			4931-006-01
5	1	PART 5			4931-005-01
4	1	PART 4			4931-004-01
3	2	PART 3			4931-003-01
2	6	PART 2			4931-002-01
1	2	PART 1			4931-001-01

SURFACE FINISH		MACHINING TOLERANCES	
UNLESS STATED OTHERWISE		UNLESS STATED OTHERWISE	
▽	ROUGH MACHINE N9	X	+/- 0.5
▽▽	FINE MACHINE N8	X	+/- 0.25
▽▽▽	GRIND N6	X	+/- 0.05
			ANGLES +/- 0.5°
			DIMENSIONS IN MILLIMETERS

Design by PLW Drawn by MDB Copied - Checked - Standard A1 Affirmed - Scale -

DAWSON CONSTRUCTION PLANT LTD. SWAN NECK

Sheet 1 of 12 Date 16/03/2012 Drawing no. 4931-000-01



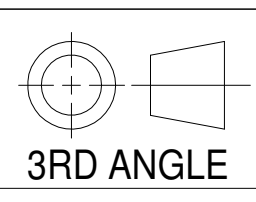

11	12
Revision	Date
Intro.	Appr.by
A	PLW
Qnt.	PROF. CHANGES
	25-01-13
	Intro.

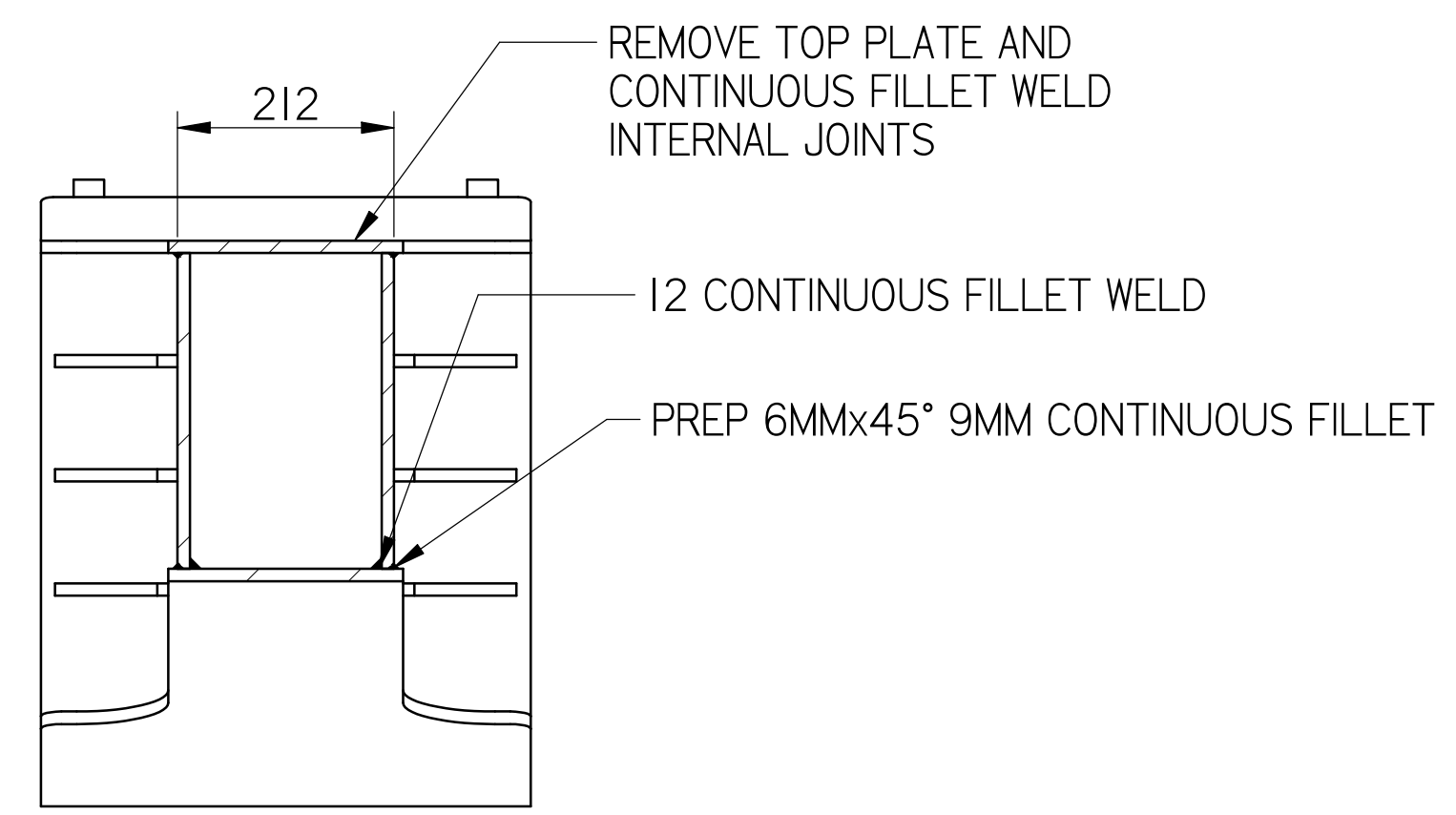
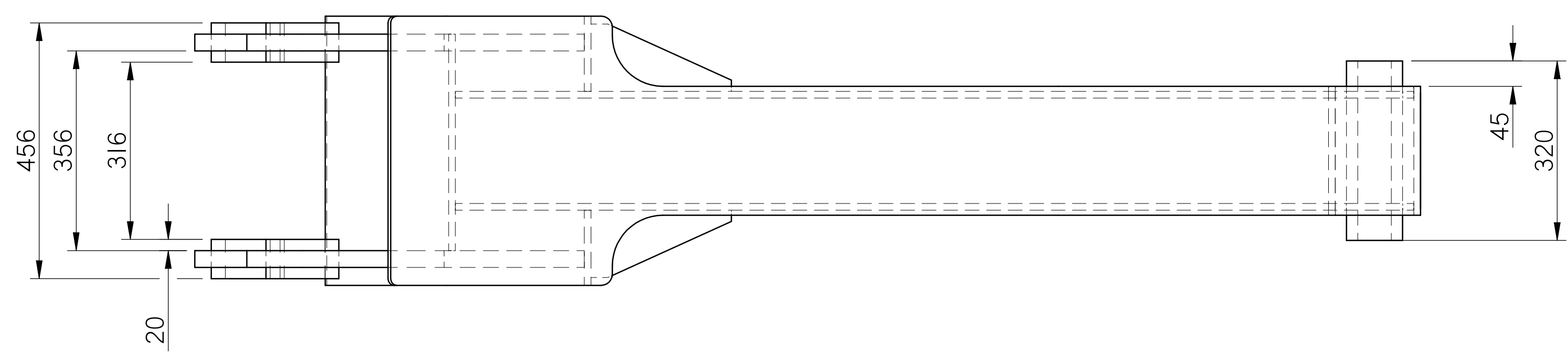
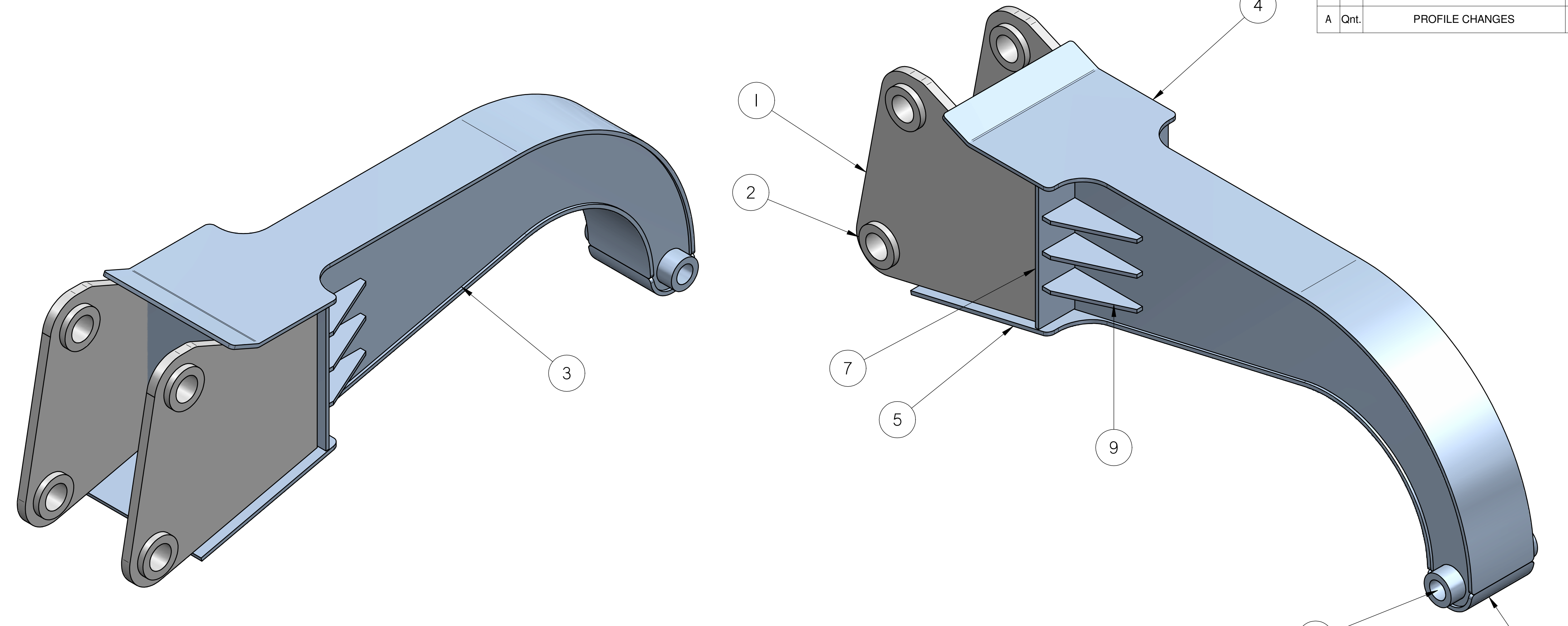

SECTION C-C

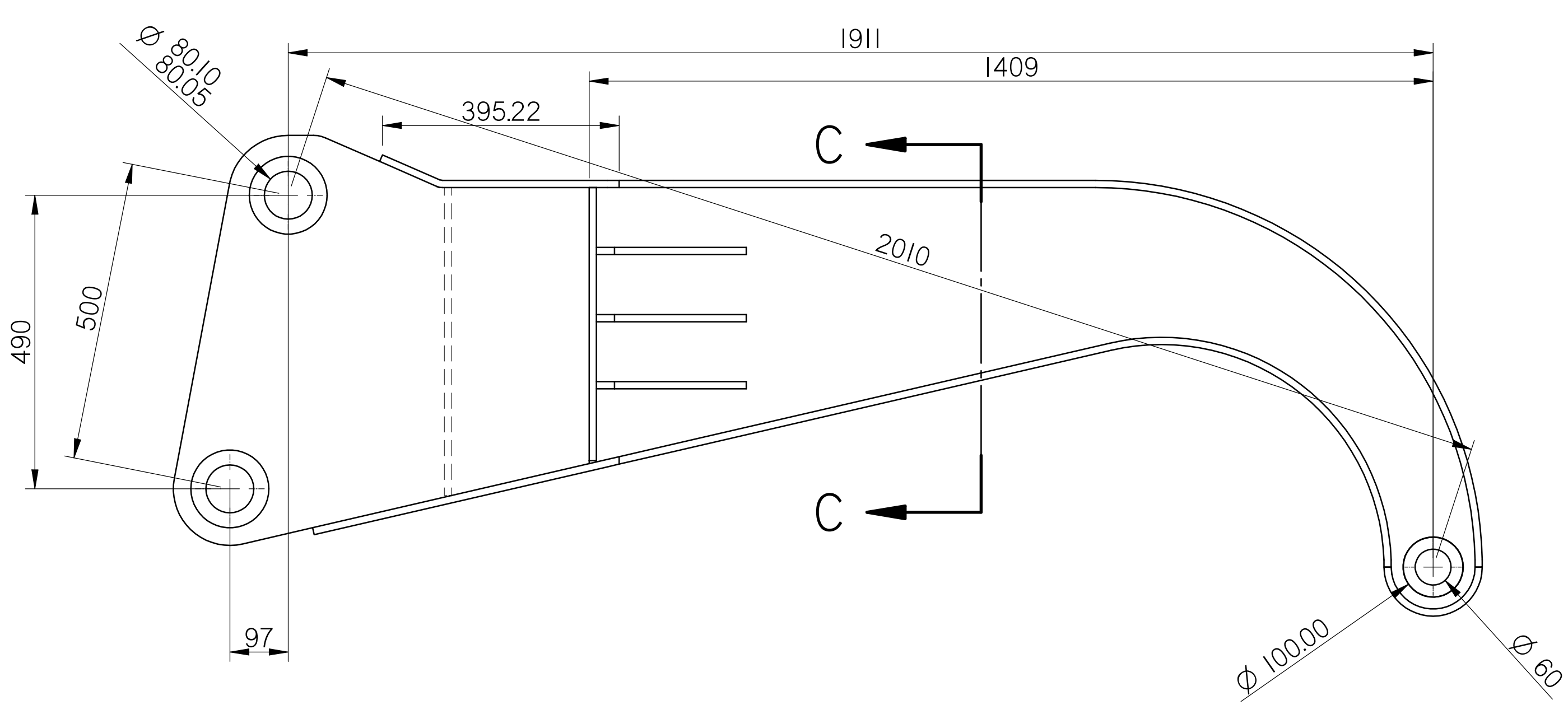

ALL JOINTS FULLY WELDED CONSTRUCTION  
 MATERIAL: GRADE S355JR, BS4360 GR50B  
 REMOVE ALL BURRS AND SHARP EDGES  
 WEIGHT 470 KG

SURFACE FINISH		MACHINING TOLERANCES	
UNLESS STATED OTHERWISE		UNLESS STATED OTHERWISE	
▽ ROUGH MACHINE N9	X = +/- 0.5	X . X = +/- 0.25	
▽ FINE MACHINE N8	X . XX = +/- 0.05	ANGLES +/- 0.5°	
▽ GRIND N6		DIMENSIONS IN MILLIMETERS	

10	1	PART 10			SN01-010-01
9	6	PART 9			SN01-009-01
8*	1	PART 8			SN01-008-01
7	2	PART 7			SN01-007-01
6	1	PART 6			SN01-006-01
5	1	PART 5			SN01-005-01
4	1	PART 4			SN01-004-01
3	2	PART 3			SN01-003-01
2	4	PART 2			4932-02
1	2	PART 1			4932-01

Ref.no.	Qnt.	Part name	Material	Dimension	Remark
Design by peter watt	Drawn by peter watt	Copied -	Checked -	Standard A2	Affirmed -
Scale -			Replace -	Replaced by -	
Sheet 1 of 11			Date 22/01/2013		
Drawing no. 4932					



DAWSON  
CONSTRUCTION  
PLANT LTD.

SWAN NECK

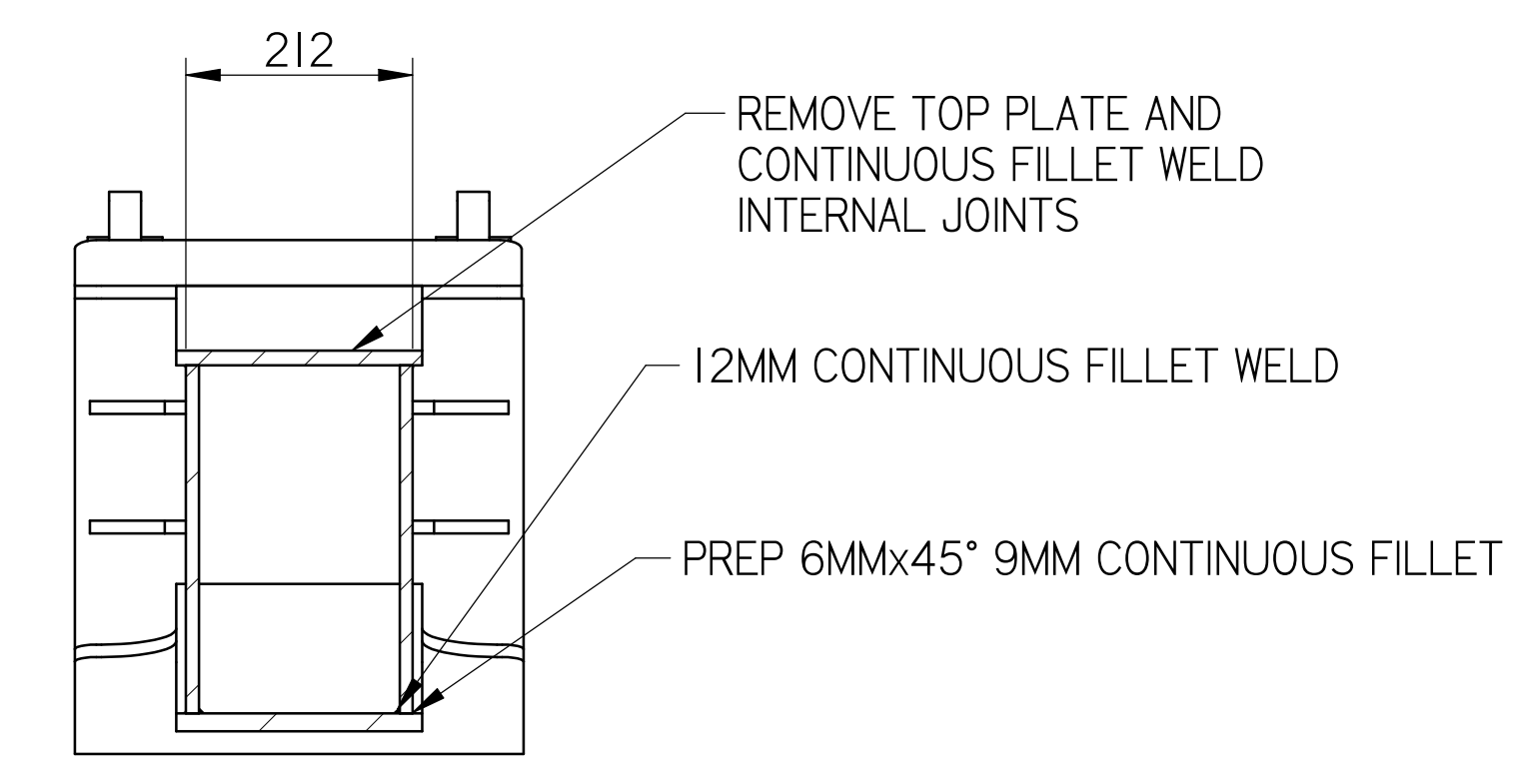
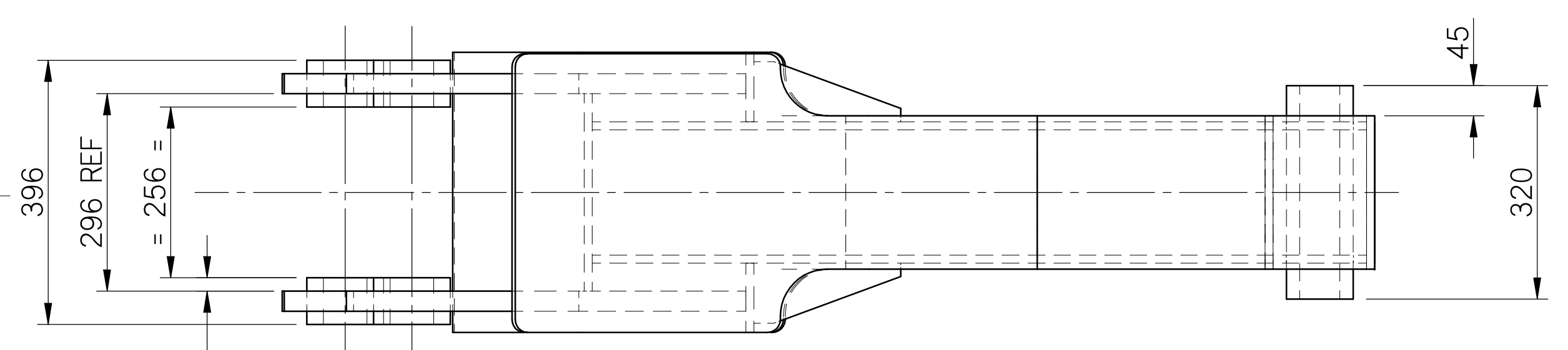
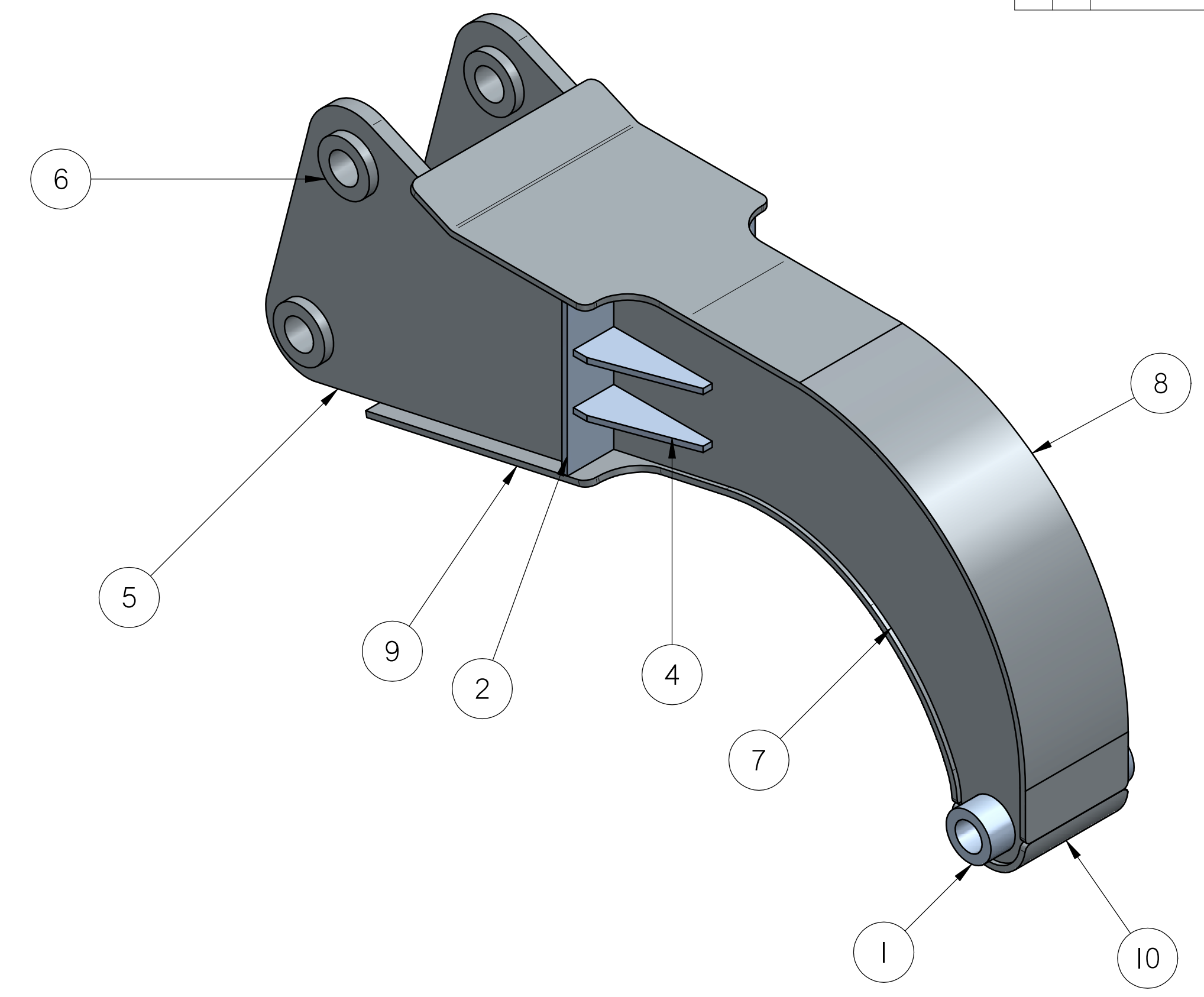
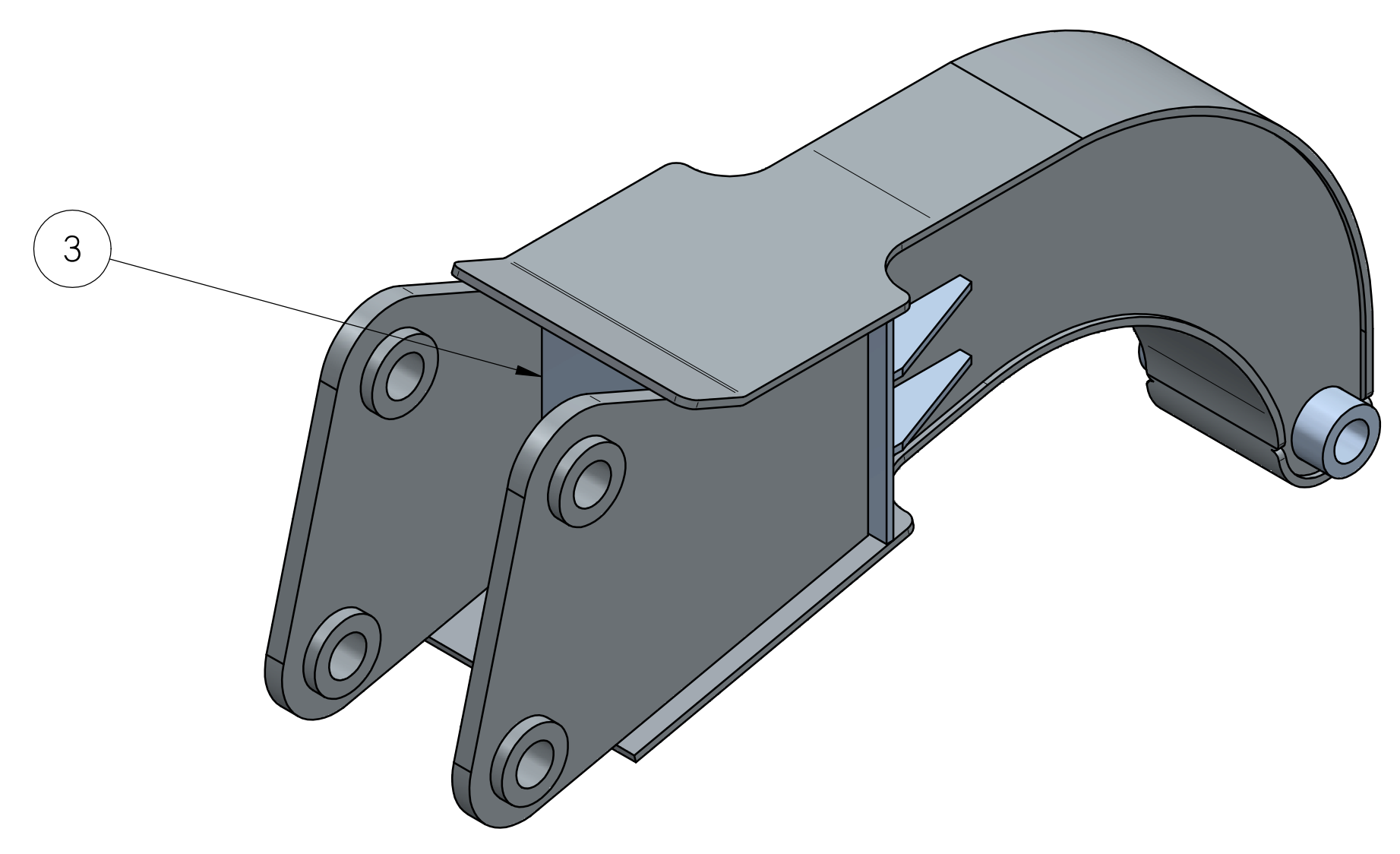
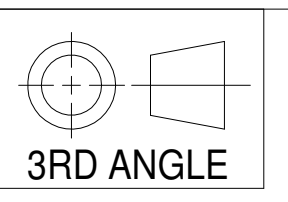

SECTION C-C

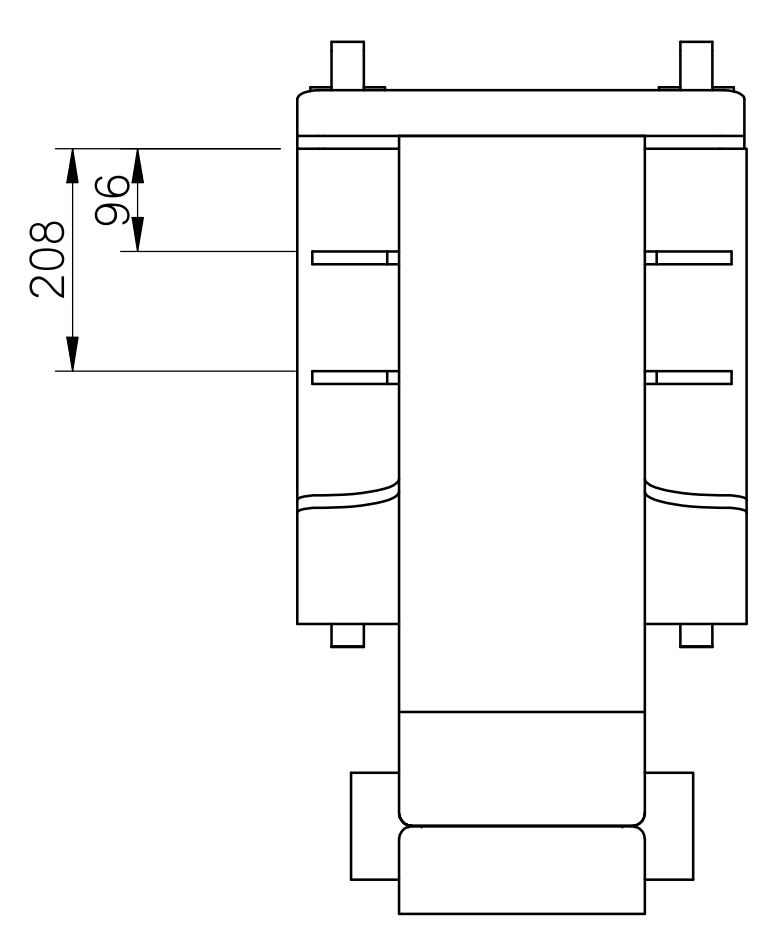
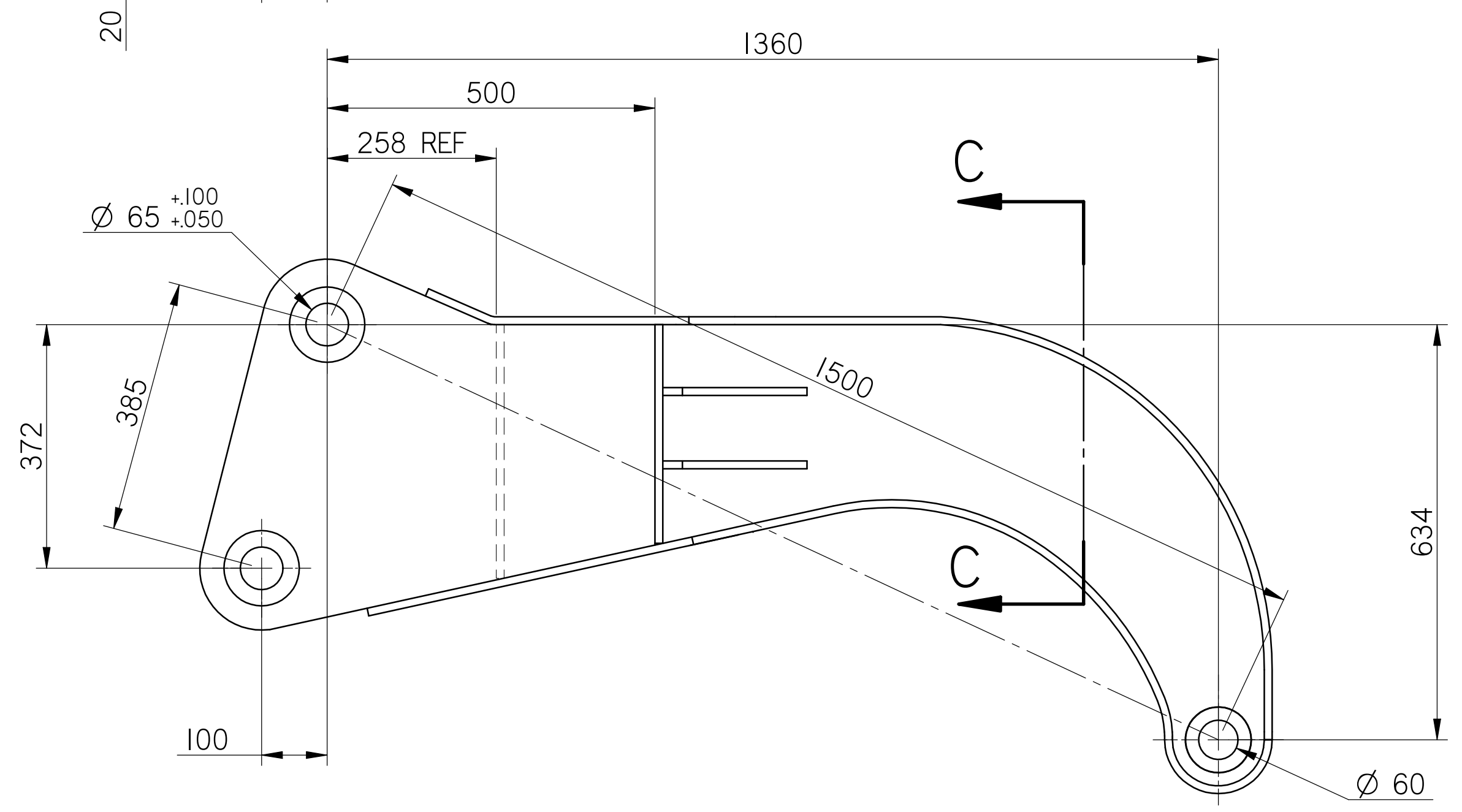

10	1	TUBE PROFILE PLATE			4934-20
9	1	BOTTOM PLATE PROFILE			4934-15
8	1	TOP PLATE PROFILE			4934-14
7	2	SWAN NECK PROFILE			4934-13
6	4	BOSS			4934-12
5	2	CONNECTION PLATE			4934-11
4	4	SIDE RIB			4934-09
3	1	BACK SUPPORT PLATE			4934-08
2	2	MIDDLE SUPPORT PLATE			4934-07
1	1	TUBE			4934-06

<b>SURFACE FINISH</b> UNLESS STATED OTHERWISE	<b>MACHINING TOLERANCES</b> UNLESS STATED OTHERWISE
▽ ROUGH MACHINE N9	X = +/- 0.5
▽▽ FINE MACHINE N8	X . X = +/- 0.25
▽▽▽ GRIND N6	X . XX = +/- 0.05
	ANGLES +/- 0.5°
	DIMENSIONS IN MILLIMETERS

ALL JOINTS FULLY WELDED CONSTRUCTION  
MATERIAL: GRADE S355JR, BS4360 GR50B  
REMOVE ALL BURRS AND SHARP EDGES  
WEIGHT 340 KG

Ref.no.	Qnt.	Part name	Material	Dimension	Remark
Design by MDB	Drawn by MDB	Copied -	Checked -	Standard A2	Affirmed -
DAWSON CONSTRUCTION PLANT LTD.			SWAN NECK 1500MM		Replace - Replaced by - Sheet 1 of 4 Date 15/12/2015 Drawing no. 4934

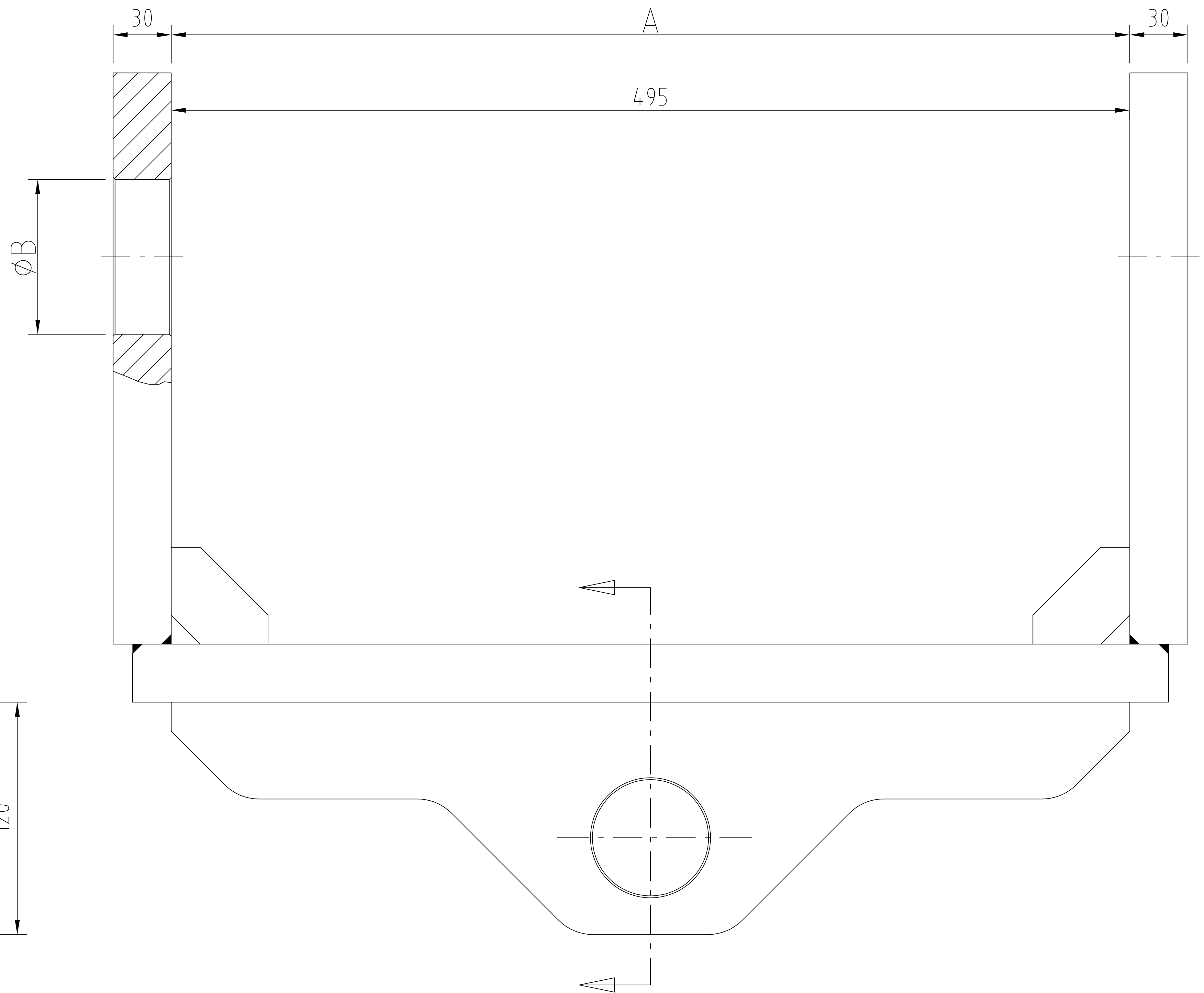
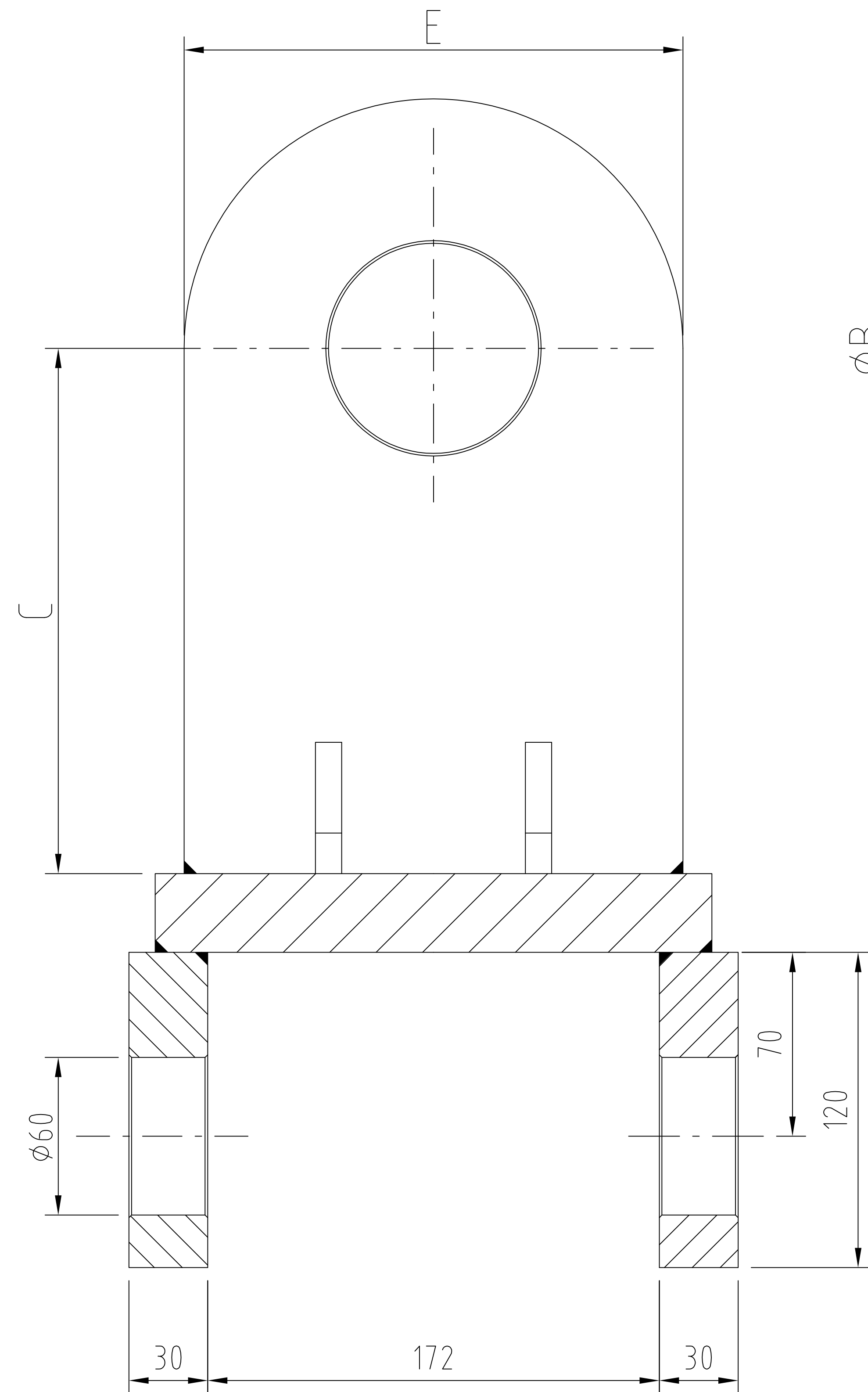

Part Number	Dimensions - mm				Dipper Pin Part Number
	A	$\phi B$	C	E	
4063	340	60.00	175	140	4089
4063A	495	80.00	200	190	4089A
4063C	458	89.50	225	190	4089C
4063D	410	60.00	200	190	4089D
4063E	458	60.00	225	190	4089E
4063F	495	63.75	200	190	4089F
4063M	458	63.75	225	190	4089M
4063R	495	69.85	225	190	4089R

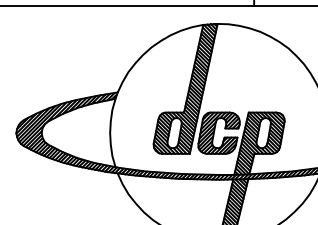
Ref.no.	Qnt.	Part name			Material	Dimension	Remark	
Design by M.LEE	Drawn at	Copied	Checked	Standard A3	Affirmed	Scale 1 : 2.5	Replace	Replaced by
 <b>DAWSON CONSTRUCTION PLANT LTD.</b>							File name	Date 03-05-06
							Drawing no. 4063SummaryTable	

EMV ADAPTOR BRACKETS





(E) A SET OF SLEEVES ARE INCLUDED WITH QUICK HITCH DIAMETER TO BE ADVISED WHEN PLACING ORDER

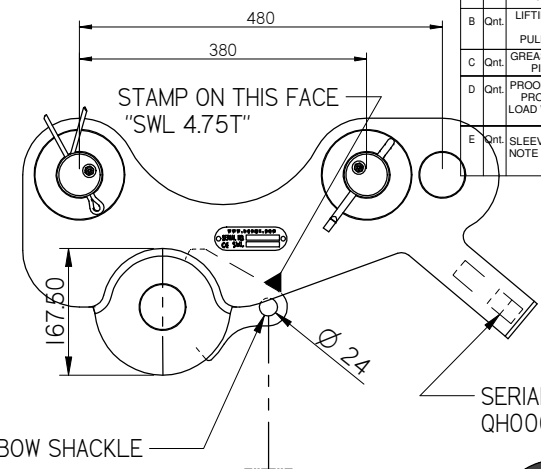
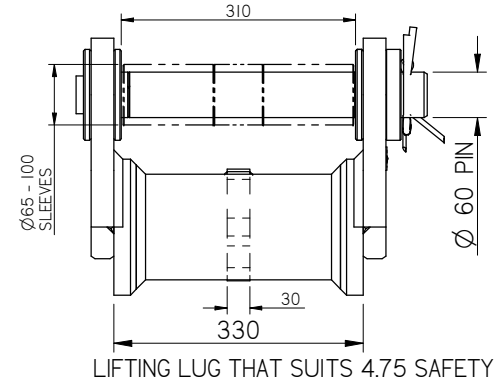
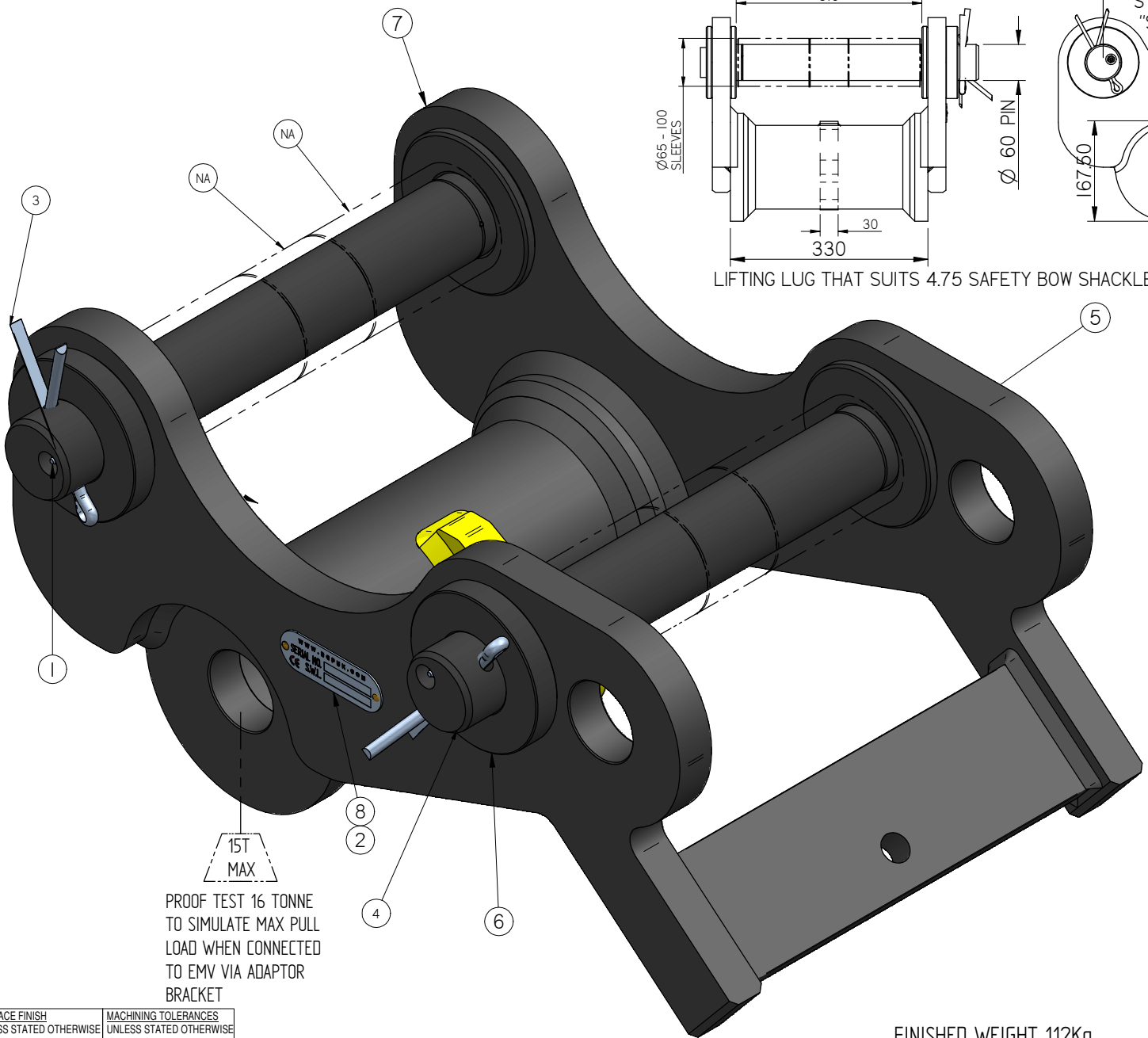

Rev.	Qnt.	Revision	Date	Intr.	Appr. by
A		NOW Ø80MM SLEEVES WAS 70MM 20MM WASHERS WERE 10MM	010812	Intr.	PLW
B		LIFTING LUG ADDED. WEIGHT WAS 105KG PULL TEST AND CE MARK ADDED	110313	Intr.	PLW
C		GREASE NIPPLES ADDED TO DIPPER PINS WERE 4089 NOW 4089G	180313	Intr.	PLW
D		PROOF TEST WAS 12T NOW 9.5T AND PROOF 16T ADDED AS MAX PULL LOAD WHEN CONNECTED TO EMV VIA ADAPTOR BRACKET	030413	Intr.	PLW
E		SLEEVES REMOVED FROM DRAWING, NOTE ADDED ABOUT SLEEVES AND 2 off 4324 WERE 4090	150913	Intr.	PLW

SERIAL NUMBER STAMPED HERE QH000, QH001, QH002 etc.

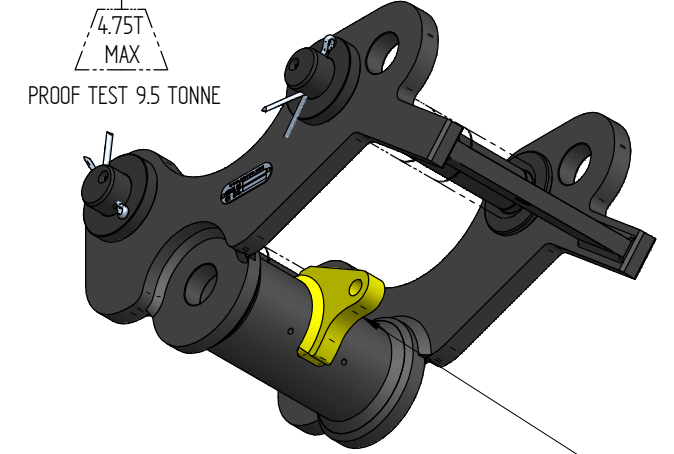

PAINT LIFTING LUG YELLOW

FOR TESTING FIT A 4.75T SAFETY BOW SHACKLE THROUGH THE LIFTING LUG AND APPLY A LOAD OF 9.5 Tonne REACTING AGAINST THE TWO DIPPER PINS, TEST TO BE REPEATED WITH THE DIPPER PIN IN BOTH LOCATIONS.

15T MAX  
PROOF TEST 16 TONNE TO SIMULATE MAX PULL LOAD WHEN CONNECTED TO EMV VIA ADAPTOR BRACKET

FINISHED WEIGHT 112Kg

SURFACE FINISH UNLESS STATED OTHERWISE	MACHINING TOLERANCES UNLESS STATED OTHERWISE
▽ ROUGH MACHINE N9	X = +/- 0.5
▽ FINE MACHINE N8	X, X. = +/- 0.25
▽ GRIND N6	X, XX = +/- 0.05
	ANGLES +/- 0.5°
	DIMENSIONS IN MILLIMETERS

Ref.no.	Qnt.	Part name	Material	Dimension	Remark
8	1	SHACKLE ID PLATE	ALUMINIUM		5938
7	1	Quick Hitch Fab	BE4360 En50B		4586 FAB
6	2	INSTALLATION BUSH	Ø120 X 20		4324
5	4	DIPPER PIN WASHER			4090
4	2	DIPPER PIN			4089G
3	2	SPLIT PIN			4067
2	2	Nø6 x 1/2" Rivet			1-204-000-01
1	4	GREASE NIPPLE	1/8" BSP		1-057-00-01

Design by	Drawn by	Copied	Checked	Standard	Affirmed	Scale	Replace	Replaced by
peter watt	peter watt	-	-	A2	-	-	-	-

DAWSON CONSTRUCTION PLANT LTD.		Quick Hitch Assy		Sheet 1 of 1	Date 06/03/2012
Drawing no. 4586					





Rev.	Qnt.	Revision	Date	Intr.	Appr. by
A		SLEEVES REMOVED FROM BOM 4324 WAS 4090	25-09-13	Intr.	PLW

STAMP ON THIS FACE  
"SWL 4.75T"

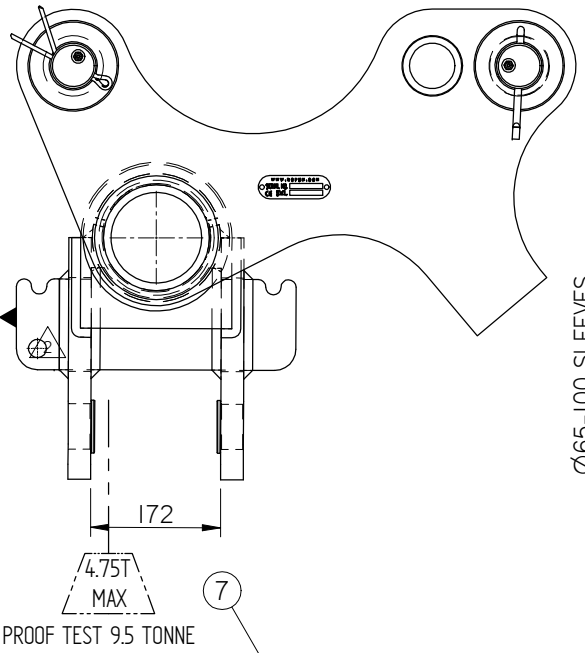

LIFTING LUG THAT SUITS 4.75 SAFETY BOW SHACKLE

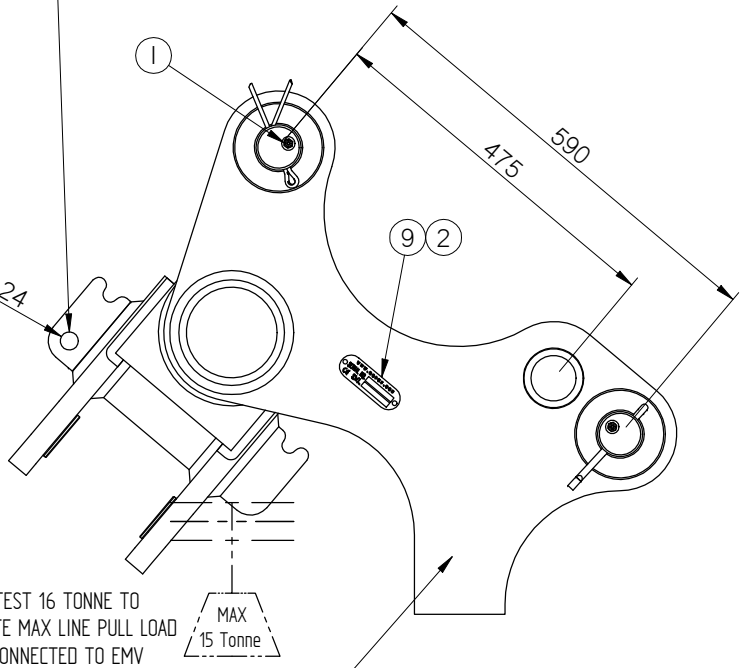
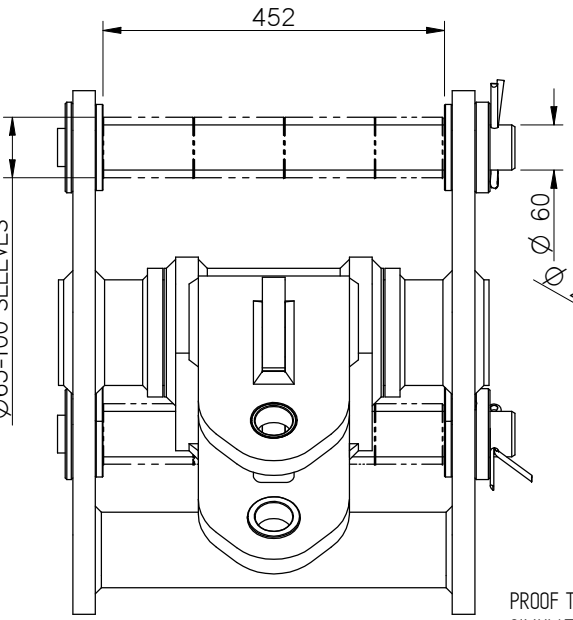

SERIAL NUMBER STAMPED HERE  
QH000, QH001, QH002 etc.

FOR TESTING FIT A 4.75T SAFETY BOW SHACKLE THROUGH  
THE LIFTING LUG AND APPLY A LOAD OF 9.5 Tonne  
REACTING AGAINST THE TWO DIPPER PINS, TEST TO BE  
REPEATED WITH THE DIPPER PIN IN BOTH LOCATIONS.

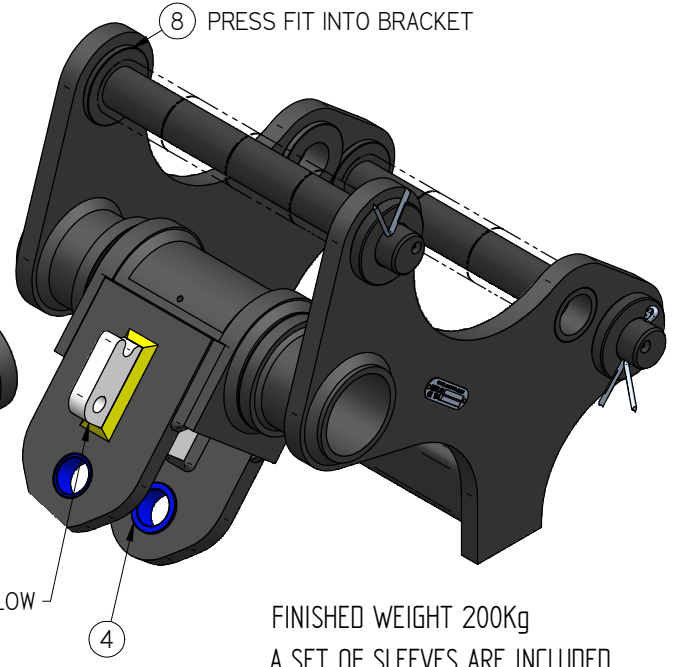
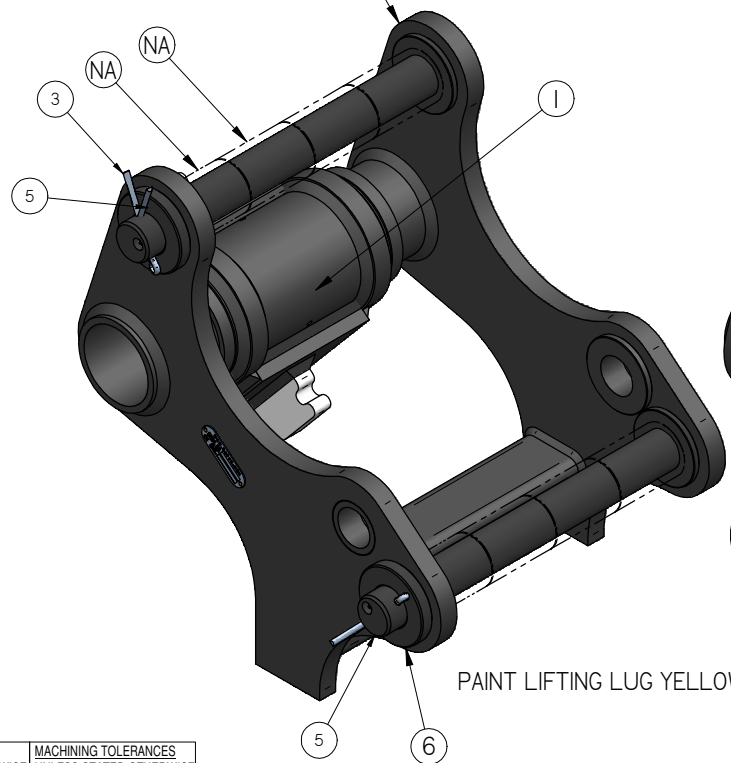

PAINT LIFTING LUG YELLOW

FINISHED WEIGHT 200Kg  
A SET OF SLEEVES ARE INCLUDED  
WITH QUICK HITCH DIAMETER, TO BE  
ADVISED WHEN PLACING ORDER

9	1	SHACKLE ID PLATE	ALUMINIUM		5938
8	6	STEPPED PRESS FIT BUSH			4589-010
7	1	Quick Hitch Fab	BE4360 En50B		4589 FAB
6	2	Installation washer		20mm thick	4324
5	2	DIPPER PIN Ø60 X 585MM			4089-005
4	2	FLANGED BUSH			4068
3	2	SPLIT PIN			4067
2	2	No6 x 1/2" Rivet			1-204-000-01
1	6	GREASE NIPPLE	1/8" BSP		1-057-00-01

Ref.no.	Qnt.	Part name	Material	Dimension	Remark			
Design by peter watt	Drawn by peter watt	Copied	Checked	Standard A2	Affirmed	Scale	Replace	Replaced by
<p>DAWSON CONSTRUCTION PLANT LTD.</p> <p>Quick Hitch Assy With integrated adaptor bracket</p>							Sheet 1 of 1	Date 01/03/2013
							Drawing no.	4589

SURFACE FINISH UNLESS STATED OTHERWISE	MACHINING TOLERANCES UNLESS STATED OTHERWISE
▽ ROUGH MACHINE N9	X = +/- 0.5
▽ FINE MACHINE N8	X, XX = +/- 0.25
▽ GRIND N6	XX, XXX = +/- 0.05
	ANGLES +/- 0.5°
	DIMENSIONS IN MILLIMETERS



# STANDARD LIFTING CHAIN ARRANGEMENT

LIFTING CHAIN FOR  
DOUBLE CLAMP - **4681D**



SWL 1.6T



EMV MODEL	TO MAINTAIN AMPLITUDE IN EXCESS OF 4MM, MAX RECOMMENDED PILE MASS
450	1000KG
550	1400KG

OVERALL  
VIEW



FITTING TO  
CHAIN HOLDER



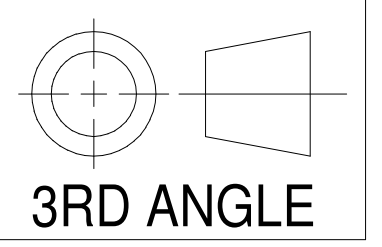

Rf.nr.	Qnt.	Revision	Date	Intro.	Appr.by
--------	------	----------	------	--------	---------

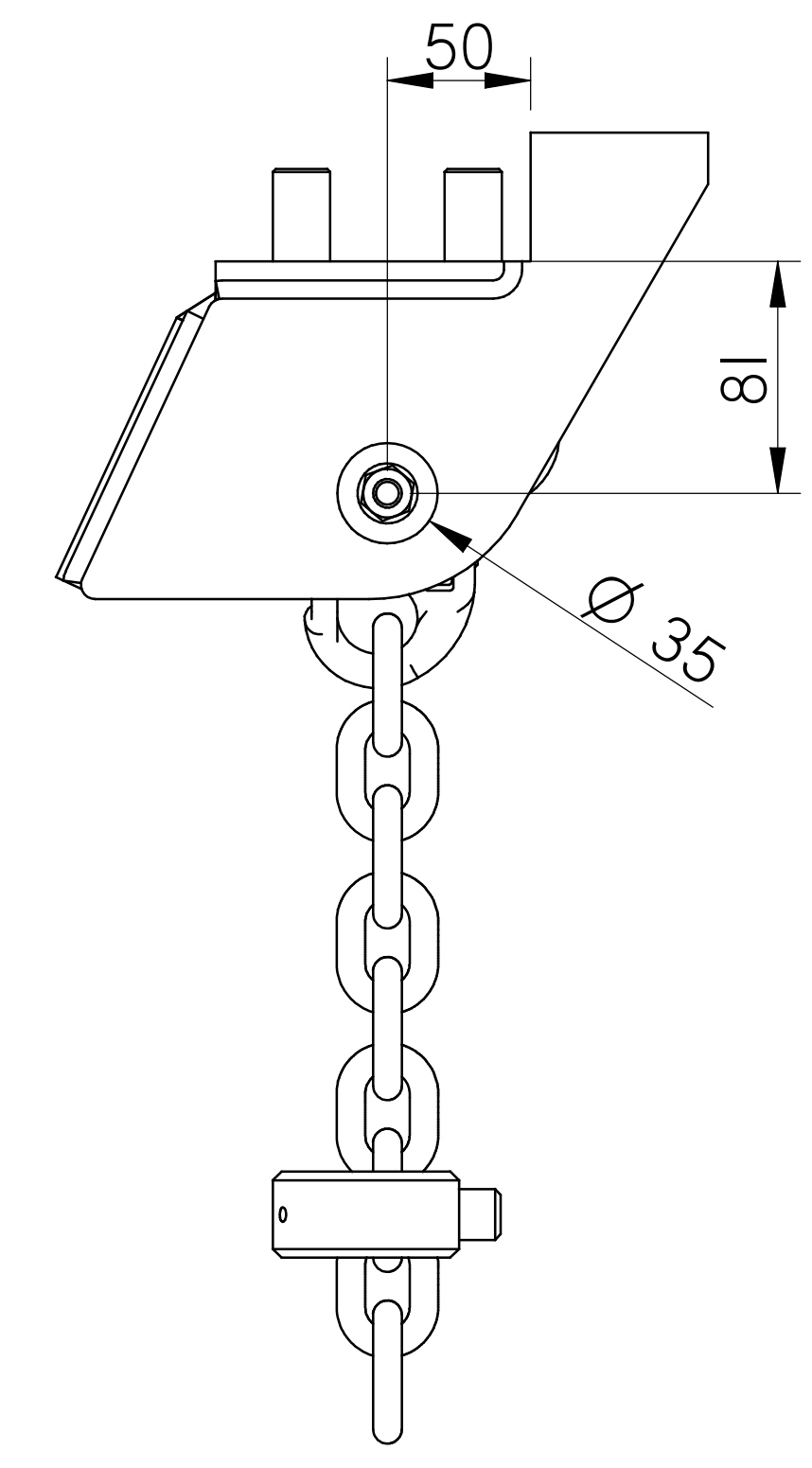
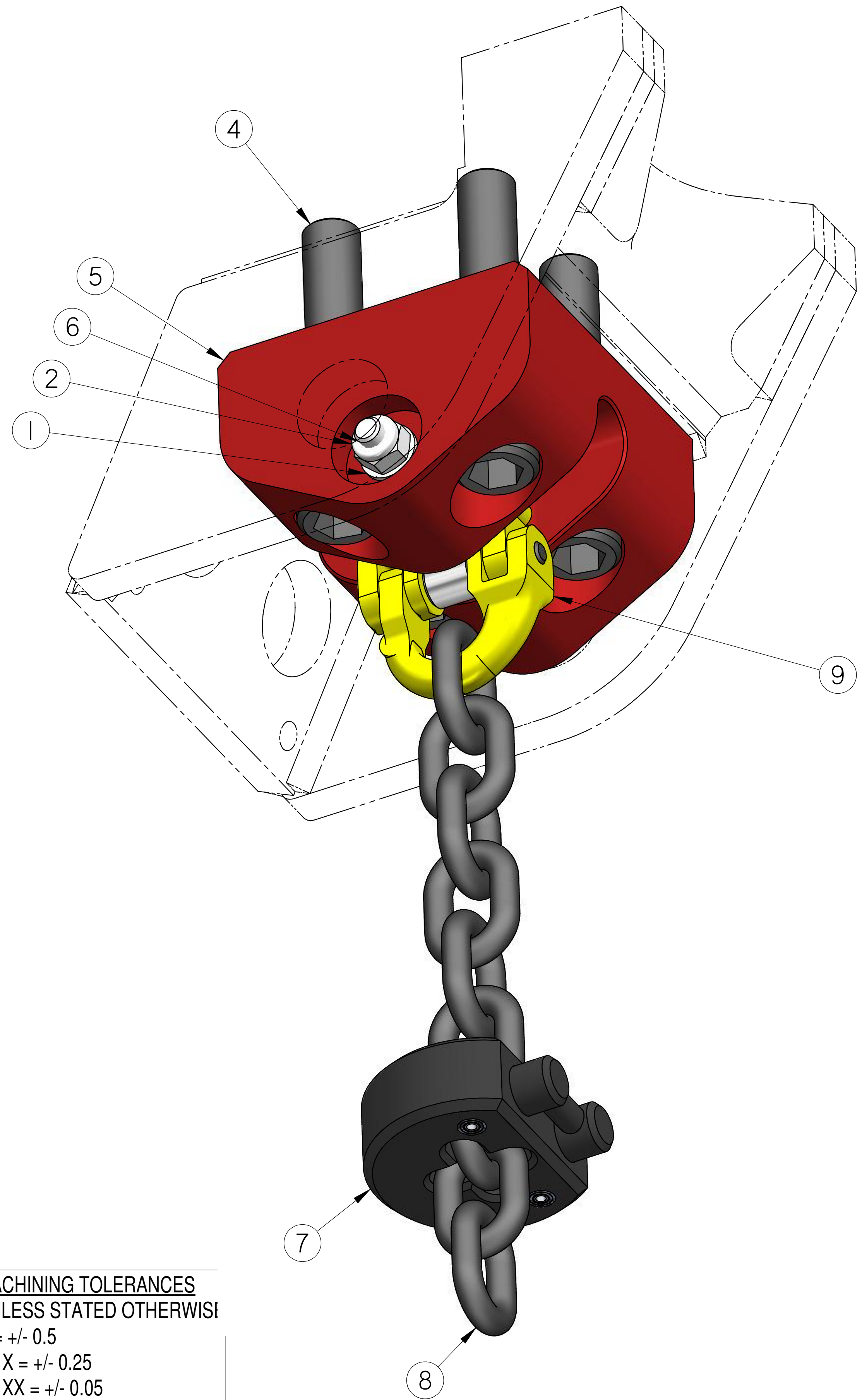

SWL for chain adaptor with 10mm chain is 3.2 Tonne.  
Pull to 6.4 Tonne for proof Load

To prove design Pull to 16 Tonne and hold for 5 minutes.

10*	1	SLEEVE			TLR368
9	1	G10 Chain Coupler			TLR362
8	1	10mm Chain			TLR361
7	1	10mm Chain Clamp			TLR360
6	1	SOCKET HEAD CAP SCREW			OM10-100-02
5	1	EMV400 SINGLE CHAIN ADAPTOR	EN50B FLAME CUT	Z4684-001-01	4684-001-01
4	4	SOCKET HEAD CAP SCREW	12.9	M20 x 100	OM20.100.02
3*	4	NORD-LOCK WASHER		M20	OM20-000-27
2	1	NYLOC NUT		M10	OM10.000.11
1	2	WASHER		M10	OM10-000-20

<b>SURFACE FINISH</b> UNLESS STATED OTHERWISE	<b>MACHINING TOLERANCES</b> UNLESS STATED OTHERWISE
▽ ROUGH MACHINE N9	X = +/- 0.5
▽▽ FINE MACHINE N8	X.X = +/- 0.25
▽▽▽ GRIND N6	X.XX = +/- 0.05
	ANGLES +/- 0.5°
	DIMENSIONS IN MILLIMETERS

Ref.no.	Qnt.	Part name	Material	Dimension	Remark
Design by peter watt	Drawn by peter watt	Copied -	Checked -	Standard A3	Affirmed -
DAWSON CONSTRUCTION PLANT LTD.					Scale -
Single chain adaptor assy					Replace -
					Replaced by -
					Sheet   of   Date 04/08/2010
					Drawing no. 4684 ADPT



**DAWSON**  
CONSTRUCTION PLANT LTD

# TIGHTENING TORQUES FOR SCREWS WITH STANDARD METRIC THREAD

Screw size	Preload values $F_M$ based on Grades in N			Tightening torques $M_A$ based on Grades in Nm			Wrench size for			
	8.8	10.9	12.9	8.8	10.9	12.9	Hex head screw		Socket head screw	
							mm	Inch	mm	Inch
M4 x 0.7	3,900	5,700	6,700	3.1	4.5	5.3	7	9/32	3	-
M5 x 0.8	6,400	9,300	10,900	6.1	8.9	10.4	8	-	4	5/32
M6 x 1	9,000	13,200	15,400	10.4	15.5	18.0	10	-	5	-
M7 x 1	13,100	19,300	22,600	17.0	25.0	30.0	11	-	-	-
M8 x 1.25	16,500	24,200	28,500	25	37	43	13	1/2	6	-
M10 x 1.5	26,000	38,500	45,000	51	75	87	17	11/16	8	-
M12 x 1.75	38,500	56,000	66,000	87	130	150	19	3/4	10	-
M14 x 2	53,000	77,000	90,000	140	205	240	22	7/8	12	-
M16 x 2	72,000	106,000	124,000	215	310	370	24	61/64	14	9/16
M18 x 2.5	91,000	129,000	151,000	300	430	510	27	1-1/16	14	9/16
M20 x 2.5	117,000	166,000	194,000	430	620	720	30	1-3/16	17	43/64
M22 x 2.5	146,000	208,000	243,000	580	970	830	32	1-9/32	17	43/64
M24 x 3	168,000	239,000	280,000	740	1,060	1,240	36	1-7/16	19	3/4
M27 x 3	221,000	315,000	370,000	1,100	1,550	1,850	41	1-5/8	19	3/4
M30 x 3.5	270,000	385,000	450,000	1,500	2,100	2,500	46	1-13/16	22	7/8
M33 x 3.5	335,000	480,000	560,000	2,000	2,800	3,400	50	2	24	61/64
M36 x 4	395,000	560,000	660,000	2,600	3,700	4,300	55	2-3/16	27	1-1/16
M39 x 4	475,000	670,000	790,000	3,400	4,800	5,600	60	2-3/8	27	1-1/16

**NOTE!**

Preload forces and tightening torques are based on lightly lubricated screws and nuts (corresponds to medium friction  $\mu_G = 0.14$ ). Nm = x 0.7375 = ft. lbs.





**DAWSON**  
CONSTRUCTION PLANT LTD

# PRE-DELIVERY INSPECTION SHEET

## EMV'S, VPC'S AND EMD'S

### MACHINE TYPE

EMV550	EMV450	EMV400	EMV300	EMV70	VPC	EMD140	EMD70	✓

Serial No:

### ADAPTOR BRACKET / QUICK HITCH ASSEMBLY

Adaptor Pin	Diameter	Length
Bushes List		
Additional Spares Supplied		

Photo taken before dispatch:

### SADDLE ASSEMBLY



Sandwich Mount Condition	✓
Buffer Stop Condition	✓
Top Swivel Condition Max gap 1mm (ideally no play)	✗
Greased	✗

Maximum gap allowed due to wear.(see photo)  
Check using a crowbar to force apart assembly, then insert a feeler gauge at least 20mm into gap, if more than 1mm change lifting bolt and nut immediately and check other components replacing as required.

Remarks:

### HOSES

Hoses Condition	✓
Spring Guard Condition	✓
Running Leaks	
Fittings	✗
Additional Spares Supplied	✗

Remarks:

### GEARBOX ASSEMBLY

Oil Level		✓ ✗
Leaks (Visual)		
Case Breather Valve		
Motor Blow off Valve		
General Condition		

Remarks:

### CLAMP ASSEMBLY

Serial No.		✓ ✗
Static Jaw Condition		
Moving Jaw Condition		
Greased		
Chain Clamp (Serial No. )		
Lifting Chain (Serial No. )		
Coupler (Serial No. )		

Remarks:

Stand:

✓ ✗

Remarks:

### VIBRO RUNNING CHECKS

Cycle Clamp x5 to Check Function		✓ ✗	
Close Clamp Stop Vibro & Leave for 5 mins (CLAMP MUST STAY CLOSED)			
Run Vibro and Check for External Leaks	Hoses		
	Fittings		
	Motor Blow Off Valve		
QRC		✗	

Inspection Time / Date:

Inspector Name:



D.C.P. RESERVES THE RIGHT TO DISCONTINUE EQUIPMENT AT ANY TIME, OR CHANGE SPECIFICATIONS OR DESIGNS WITHOUT NOTICE OR INCURRING OBLIGATIONS

---

INNOVATIVE PILING EQUIPMENT

---

---

---

HYDRAULIC PILING HAMMERS

EXCAVATOR MOUNTED VIBRATORS

EXCAVATOR MOUNTED DRILLS

QUIET, VIBRATIONLESS PUSH-PULL PILING

PILE EXTRACTION

SHEET PILE GUIDE FRAMES

SHEET PILE CAPPING SYSTEMS

CFA CLEANERS

PILE POINTS & SPLICERS

SAFETY HANDLING / LIFTING EQUIPMENT

SHEET PILE THREADERS

---

excavator mounted vibrator  
emv550

DAWSON CONSTRUCTION PLANT LTD.  
CHESNEY WOLD,  
BLEAK HALL  
MILTON KEYNES  
MK6 1NE, ENGLAND  
TEL: +44 (0) 1908 240300  
FAX: +44 (0) 1908 240222  
EMAIL: JON@DCPUK.COM



[www.dcpuk.com](http://www.dcpuk.com)